





Class G. V. 12.01  
Book B395

COPYRIGHT DEPOSIT



















THINGS WORTH DOING  
AND HOW TO DO THEM

## THE BEARD BOOKS FOR GIRLS

By LINA and ADELIA B. BEARD

---

**Things Worth Doing and How to Do Them.** Illustrated by the authors. \$2.00.

**Recreations for Girls.** Illustrated by the authors. \$2.00 (postage extra).

**What a Girl Can Make and Do.** New Ideas for Work and Play. Illustrated by the authors. \$2.00.

**The American Girl's Handy Book; or, How to Amuse Yourself and Others.** Illustrated by the authors. \$2.00.

---

## THE BEARD BOOKS FOR BOYS

By DANIEL C. BEARD

---

**The Field and Forest Handy Book.** New Ideas for Out of Doors. Illustrated by the author. \$2.00.

**The Jack of All Trades; or, New Ideas for American Boys.** Illustrated by the author. \$2.00.

**The Outdoor Handy Book.** New and Cheaper Edition of The American Boy's Book of Sport. Illustrated by the author. \$2.00.

**The American Boy's Handy Book; or, What to Do and How to Do It.** Illustrated by the author. \$2.00.



# THINGS WORTH DOING AND HOW TO DO THEM



BY  
Lina Beard  
and  
Adelia B. Beard



New York

Charles  
Scribner's  
Sons

1906

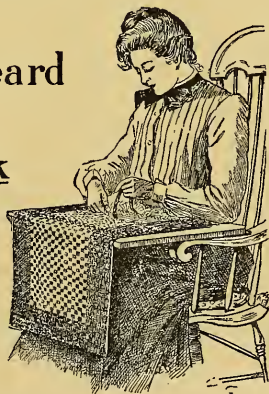

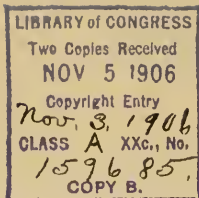

COPYRIGHT, 1906 BY  
CHARLES SCRIBNER'S SONS

SPECIAL NOTICE

The publishers hereby give warning that the unauthorized printing of any portion of the text of this book, and the reproduction of any of the illustrations or diagrams, are expressly forbidden.



TO  
OUR  
LITTLE NIECE  
BARBARA BEARD





## PREFACE

WE know our girls. We know and sympathize with their restless longing for activity. The normal girl simply must be doing something, and this ceaseless energy, at times rather appalling to her elders, is but natural and right. It is in the young blood coursing so swiftly and joyously through her veins, and it must find vent in one way or another. But there is no need of doing that which brings neither true pleasure nor the joy of accomplishing something worth while, for the world is full of delightful things really worth the doing. We have only to open our eyes and ears to find them crowding forward to claim our attention, and the choice is between better and best.

There are merry frolics and active games that stimulate the health and renew the vitality of the body and there are scores of charming things for willing hands to make which are not only worth the making but which bring skill to the fingers and breadth and energy to the mind.

In this, our fourth book for girls, we are giving some of the things we have found well worth the doing, and it is our hope that our girl friends will also see their worth and find in them inspiration for further experiments in pastime and frolics.

THE AUTHORS

July 3, 1906.



# CONTENTS

---

## PART I

### PARTIES, SHOWS AND ENTERTAINMENTS

---

#### CHAPTER I

	PAGE
A FOURTH OF JULY LAWN FROLIC .....	3
Ground Decoration, 3; Firecracker Invitation, 4; Pantomime Charades, 6; To Make the Sun-bonnet, 7; Shuffle Race, 10; Hurling the Lance, 10; Daylight Fireworks, 11; Balloon Ascension, 11; The Myth, 12; Pandora Box, 12; The Balloons, 13.	

#### CHAPTER II

A WONDERFUL CIRCUS AT HOME WITH MOVING ANIMALS.....	15
Mademoiselle Rosebud, 16; To Give the Horse Power to Move, 18; Bob, the Wonderful Elephant, 20.	

#### CHAPTER III

A NOVEL EASTER PARTY WITH NEW EASTER GAMES .....	33
Egg Tennis, 33; Number of Eggs, 33; To Prepare the Eggs, 34; Shower of Paper, 36; The Rackets, 38; The Game, 39; Butterfly Game, 42; Magic Dye Kettle, 43.	

#### CHAPTER IV

A DOORWAY PUNCH AND JUDY SHOW.....	45
The Stage, 45; To Make Punch's Head, 46; Punch's Dress, 50; Judy's Head, 51; The Baby, 52; Drama of Punch and Judy, 53.	

	PAGE
CHAPTER V	
HALLOWE'EN MERRYMAKING .....	55
<p style="padding-left: 40px;">Novel Ways of Telling Fortunes, 55; Invitation Rings of Grass, 55; Black Cats, 56; Pair of Old Slippers, 58; Cups and Bowls, 59; The Wedding Race, 61; The Vesper Rite, 65; Bean Bag Test, 66; The Witch Screen, 66; Fairy Airships, 70; Blarney Stone Game, 71.</p>	
CHAPTER VI	
DANCE OF TITANIA, QUEEN OF THE FAIRIES .....	75
<p style="padding-left: 40px;">The Stage, 75; Titania, 79; Costume, 82; Wings, 83.</p>	
CHAPTER VII	
THANKSGIVING PARTY .....	85
<p style="padding-left: 40px;">Apple, Orange and Pumpkin Games, 85; Game Court, 90; The Game, 92; Rapid-Transit Thanksgiving Story, 92; Pumpkin Lantern, 93; Forfeit, 95.</p>	
CHAPTER VIII	
IMPROMPTU MOVING PICTURES FOR THANKSGIVING .....	97
<p style="padding-left: 40px;">Puritan Woman's Dress, 98; Puritan Man's Costume, 98; The Properties, 101; A Pantomime, 102.</p>	
CHAPTER IX	
A VALENTINE ENTERTAINMENT WITH ORIGINAL VALENTINES.....	103
<p style="padding-left: 40px;">The Post-Office, 104; Valentine Stamps, 107; When the Bell Rings, 107; Heart Valentine, 109; World Valentine, 109; Daisy Valentine, 110; Love's Palette, 111.</p>	
CHAPTER X	
THE WILD WEST SHOW ON A TABLE .....	113
<p style="padding-left: 40px;">A Panorama, 113; Pasting Pictures, 120; The Performers, 120; A Tent, 123.</p>	

CHAPTER XI

PAGE

ROOF PICNIC WITH BROOK TO CROSS AND FLOWERS TO PICK .... 127  
 Sunflowers, 127; Hollyhocks, 129; Roses, 130; Peaches, Plums  
 and Apples, 130; On the Roof, 131; Country Picnic, 132;  
 Crossing the Brook, 133; Japanese Tag, 134.

CHAPTER XII

THE MAGIC PEEP SHOW..... 137  
 The Slides, 138; The Cow Jumped Over the Moon, 139; Life  
 in Fairy Waters, 141; Easter Chicks, 143; Three Blind Mice,  
 144; Dance of the Dolls, 145; The Bouquet, 147; The Little  
 Sun-bonnet Girl, 149.

CHAPTER XIII

PLANT YOUR GARDEN IF YOU CAN..... 153  
 A New Flower Game, 153; Marking Out Flower Beds, 157;  
 Flags, 157; The Rackets, 158; The Game, 159; A Tally  
 Card, 159; To Determine Choice of Sides, 160.

CHAPTER XIV

JOLLY LITTLE SANTA CLAUS WITH HIS REINDEER AND SLEIGH... 163  
 The Sleigh, 164; Reindeer, 165; Santa Claus, 168; Christmas  
 Gifts, 170; Christmas Cards, 172.

CHAPTER XV

A LIVING CHRISTMAS TREE ..... 173  
 How to Prepare, 173; The Peaked Hat, 174; To Decorate, 177.

CHAPTER XVI

HOW TO GET UP A GIRLS' FAIR ..... 179  
 A Managing Committee, 179; Blackbirds, 181; Packages for the  
 Blackbirds, 184; Express Office, 186; Letters, 187; Post-  
 Office, 187; Decorations, 187; Postmaster, 192.

CHAPTER XVII	PAGE
CAMPING OUT IN YOUR BACK YARD .....	194
Camping Outfit, 194; Tent, 197; Table, 198; Safe, 199; Spring, 200; A Fine Pail, 201; Camp-fire, 201; A Boat, 202; Out Fishing, 204.	

### CHAPTER XVIII

OUTDOOR FUN WITH HOME-MADE TETHER BALL .....	207
The Pole, 207; The Cover for the Ball, 207; A Court on the Grounds, 211; A Pattern for the Rackets, 214; The Object of the Game, 215.	

## PART II

### MINIATURE SEVEN WONDERS OF THE WORLD

#### CHAPTER XIX

THE PYRAMIDS OF EGYPT .....	219
Cheops's Home, 219; The Pyramid, 220; Carving the Wonderful Sphinx, 225; Making the Date Palm, 227; Making the Camels, 228.	

#### CHAPTER XX

THE COLOSSUS OF RHODES .....	233
Island of Rhodes, 233; To Make the Colossus, 234; Mark the Features, 238; The Pedestal, 240.	

#### CHAPTER XXI

THE PHAROS OF ALEXANDRIA AND THE MAUSOLEUM OF HALICARNASSUS .....	245
The First Lighthouse, 245; The Building Lot, 246; The Foundation, 248; The Marble Steps, 252; An Artificial Island, 254; The Mausoleum of Halicarnassus, 255.	

---

CHAPTER XXII

PAGE

THE STATUE OF ZEUS AT OLYMPIA ..... 259  
Throne of White Cardboard, 263; Upper Dais, 264; Footstool,  
265; Inlaying the Throne with Ebony, 267; The Drapery,  
267; Winged Victory, 268.

CHAPTER XXIII

THE TEMPLE OF DIANA AT EPHEBUS ..... 269  
Ionic Column, 269; The Ground Plan, 270; The Outer Row  
of Columns, 271; A Cella, 271; The Goddess Diana, 272;  
Marble Steps, 274; The Side Steps, 276.

CHAPTER XXIV

HANGING GARDENS OF BABYLON ..... 279  
The King's Wife, Amytis, 279; The Foundation, 280; To Make  
the Twelve Openings, 281; The Babylonian Arches, 283;  
Last Platform, 285; To Find the Centre, 285; Planting Shrubs  
and Trees, 287; Building the Steps, 289; Stone Broad-fronted  
Bulls, 293; Two Statues, 294; The Shrubbery, 297.

---

PART III

THINGS TO MAKE FOR HOME, GIFT DAYS  
AND FAIRS

---

CHAPTER XXV

NEW CHRISTMAS DECORATIONS ..... 303  
Paper, 303; Holly, 304; Holly Berries, 307; Wreaths, 310;  
For Mistletoe, 310; Stems, 311; Ropes of Evergreen, 312.

CHAPTER XXVI		PAGE
DOLL HOUSE OF PASTEBOARD .....		315
Windows and Doors, 316, 317; Doorknobs, 317; Window Glass, 318; Window Sash, 319; The Frieze, 322; A Rug for the Living Room, 323; Book Shelves, 324; Tissue Paper Curtains, 324.		
CHAPTER XXVII		
THE MAKING OF A BAYBERRY CANDLE .....		326
Bayberry Bushes, 326; The Leaves, 329; The Berries, 330; Ready for the Candles, 330; Bayberry Wax, 331; Candle Moulds, 331; Candlewicks, 334.		
CHAPTER XXVIII		
WATER TOYS—LITTLE WAX PEOPLE THAT SWIM AND RIDE ON RAFTS		338
Patterns for the Little People, 338; A Toy Life Rope, 340; The Bathing Place, 341; For the Raft, 341; A Little Lumberman, 344; Launching the Raft, 345; Making the Mermaid, 345.		
CHAPTER XXIX		
HOW TO WEAVE WITHOUT A LOOM .....		349
Method Invented by the Author, 349; A Weaving Board, 349; Directions for a Blue and White Cotton Rag, 350; To Weave, 352; To Lengthen the Warp, 353; To Make a Heavier Rug, 357.		
CHAPTER XXX		
HOW TO MAKE YOUR OWN EASTER CARDS AND GIFTS .....		358
Cards Representing Easter Flowers, 358; The Cross, 360; The Tulip Bud, 361; The Dainty Bloodroot, 363; Easter Egg Card, 363; Easter Bells, 364; To Make the Turtle, 366; The Pig, 367; The Spoon, 368; An Umbrella, 369; The Doll's Chair, 370; Strawberry, 371; Doll's Cradle, 372; Bird's Nest, 373; Sail Boat, 373; Napoleon, 375; Josephine, 379.		



## CHAPTER XXXI

PAGE

HOME-MADE CANDLESTICKS .....	385
The Clay, 385; Modelling Tools, 387; Strong Table, 387; China Saucer, 388; A Close-Coil, 389; The Handle, 393; Blending of Decoration, 394; How to Preserve Unfinished Work, 395; Glazing, 395; Other Methods of Coloring Pottery, 396.	

## CHAPTER XXXII

WHAT TO MAKE OF BANANAS, ORANGES AND APPLES.....	399
An Orange-skin Coracle, 400; A Canoe Made from a Banana Skin, 401; Apple Lantern or Fairy Lamp, 403.	

## CHAPTER XXXIII

LITTLE PAPER COLUMBUS AND HIS PAPER SHIP.....	405
Columbus's Ship, 406; To Make the Mizzenmast, 408; The Bow-sprit, 408; The Forward Deck, 409; Deck-Fence, 410; A Spar, 410; The Mainmast, 411; The Sails, 411; A Paper Flag, 412; Main-Topsail, 412; Crow's Nest, 412; The Jigger Sail, 413; Wigwams, 416; Ferdinand and Isabella, 417.	

## CHAPTER XXXIV

HOW TO MAKE FRIENDS WITH THE STARS.....	418
Ursa Major, 418; Ursa Minor, 420; A Fairy Tale about the Starry Bears, 421; Cassiopeia, 421; Leo, the Lion, 422; Northern Crown, 423; Castor and Pollux, 423; Orion, 424; Taurus, 425.	

## CHAPTER XXXV

STENCIL PAINTING AND HOW TO MAKE THE STENCILS.....	426
Dyes, 426; A Portière, 427; To Make a Design for Stencilling, 428; Stencilling Cheese-cloth Curtains, 433; The Tassels, 435; Laundering, 438.	



PART I  
PARTIES, SHOWS, AND  
ENTERTAINMENTS



## CHAPTER I

### A FOURTH OF JULY LAWN FROLIC



**HIS** is not to be a formal lawn party, but a genuine, fun-provoking Fourth of July frolic with every one in comfortable dress appropriate for active games. There is to be no dancing, no tennis, nothing in the way of ordinary entertainment except, perhaps, the refreshments, and they too should be as nearly in keeping with the day as possible.

Prepare your guests for something novel by issuing your invitations in the form of giant fire-crackers.

#### Decorate Your Grounds

and make them as festive as possible with fluttering flags, floating streamers, red, white, and blue bunting, and Japanese lanterns. Also provide a number of small flags, one for each guest, to be worn in the hat, hair, belt, and buttonhole. This little touch of uniform will not only make the scene gayer and more exhilarating, but, like badges of an order, will have the effect of dispelling the stiffness of new acquaintances, and bringing the party closer together as members of one band of merrymakers.

**For the Giant Firecracker Invitations**

you will need several sheets of bright red tissue paper, more of white tissue paper, and some white unlined writing paper. A ball of soft white cotton string will also be required.

Cut an oblong of red tissue paper, a circular piece of white tissue paper, and a square of writing paper for each invitation. Make the red oblong six inches long and three inches wide, the circle six inches in diameter, and the writing paper four inches square. Of the paper square make a cylindrical roll that will measure about



Fig. 1.—Lay the paper cylinder on the red tissue paper.

three-quarters of an inch across the end. The easiest way to do this is to roll the paper on a candle, keeping the end edges even, and paste the side edge down while still wrapped around the candle. Pull the candle out of the paper and you have a perfect cylinder. Place the paper cylinder on the red tissue paper oblong so that there will be an even inch of red paper at each end (Fig. 1). Paste one long edge of the red paper to the cylinder and roll it on the table, bringing the opposite edge up smoothly, then paste that edge also in place (Fig. 2).

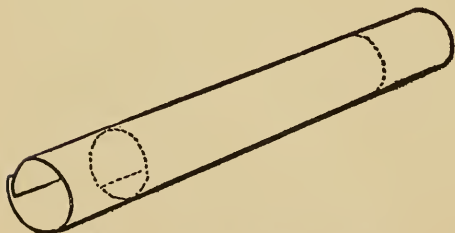

Fig. 2.—Cylinder in red paper cover.

Now prepare and write the note of invitation to be put in the firecracker envelope.

**With Short Brush Strokes,**

from inside to edge, paint an irregular band of blue, half an inch wide, around the edge of the tissue paper circle, using water colors for the purpose. Write the invitation with red ink around the circle just inside the blue border, or straight across above and below the centre.

Although the party is to be informal, a note written in the first person does not harmonize with the impersonal nature of a fire-cracker, therefore it is better to word the invitation something like this:

Miss Mary Brown requests the pleasure of the Misses Green's company at an informal lawn frolic on Wednesday, the Fourth of July, from four to six o'clock. Active games.

When the ink is quite dry pinch the paper together at the centre, making it look something like a paper flower, twist it a

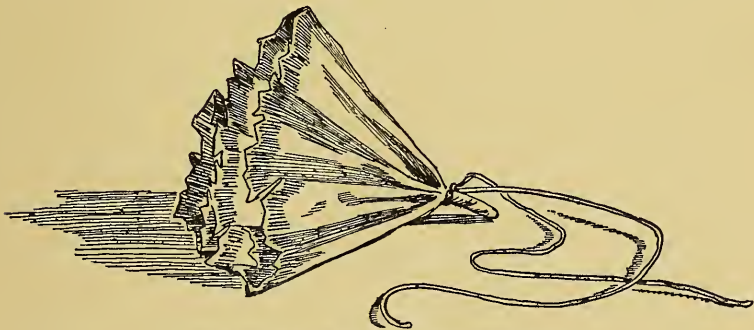

Fig. 3.—The note of invitation looks like this.

little, and tie on the point a piece of the white cotton string. The string should be about ten inches long and must be tied at the middle (Fig. 3). Drop one end of the string through the

cylinder and, taking hold of the end, draw the invitation into its envelope. Crush in the extra red paper at each end until it fills the opening and leaves the string extending from the centre

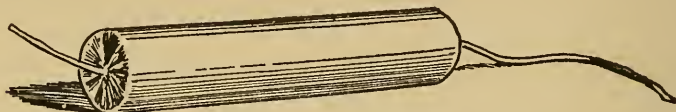

Fig. 4.—Giant firecracker with invitation inside.

(Fig. 4). Write the address and the words, "Pull the long string," on the outside of the now almost perfect giant firecracker, and deliver by hand, for such an invitation would be broken and spoiled in going through the mail.

The following

#### **Order of Entertainment**

is well adapted to the Fourth of July lawn frolic:

Out-of-door Pantomime Charades.

Shuffle Race.

Hurling the Lance.

Daylight Fireworks.

The programme opens with the not too vigorous game of

#### **Pantomime Charades.**

This will give all the opportunity of taking part and alternately acting and resting. Stake out the four corners of your stage with groups of flags, driving their sticks into the ground to hold them upright. Provide seats for the audience in front of the stage and at the back or side arrange a screen as dressing and green room for the actors.

Divide the party into two sides of equal numbers and let the





Making Hay While the Sun Shines.



first side choose a proverb to be acted out in pantomime and guessed by the opposite side, which is taking the part of audience. When the proverb is guessed the actors must retire and the other side take the stage. If the subject of the first charade is not guessed the same side must present another proverb, putting new actors in the place of those who have just taken part. Not a word must be spoken in the charade, but the actors must make their meaning as clear as possible by good acting.

Our first illustration shows the out-of-door pantomime charade in progress. The proverb is: "Make hay while the sun shines." This requires but one act as the first part, "Make hay," and the last part, "while the sun shines," are both represented. Making hay is acted out and that the sun is shining is implied by the quaint sunbonnets and wide-brimmed hats worn by the actors.

#### **The Costumes Are Impromptu,**

and may be prepared in a few minutes. The odd and most charmingly becoming bonnets, somewhat resembling Dutch caps, are made of newspapers, pinned in shape. The men's wide-brimmed hats are simply ordinary hats with wide brims made of wrapping paper. Black derby hats were worn on this occasion, but straw hats are better. The girls' dresses are turned up in front and pinned at the back. If checked gingham aprons are worn looped up at one side they will add to the color effect of the costume.

#### **To Make the Sunbonnet,**

take one folded sheet of a newspaper and turn the folded edge back four inches (Fig. 5). Fold down the corners like Fig. 6, put it on the head, bring the straight edge together at the back and pin it with a large pin. Bend out the laps at the sides and

you have made Fig. 7; Fig. 8 gives the pattern of the boy's hat. Cut a large circle from rather stiff, new wrapping paper; press it down upon the top of the crown of a man's straw hat; crease it

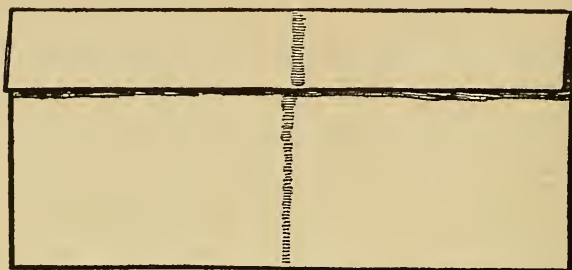

Fig. 5.—Fold the newspaper for the bonnet like this.

along the edge of the crown, then cut a hole in the centre two inches within the creased line. Slash from the inner edge to the creased line as shown in Fig. 8, fit the paper brim over the crown of the straw hat and pin in place to the hat band.

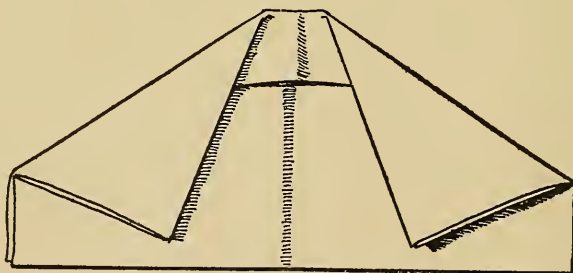

Fig. 6.—Fold down the two corners.

High peaked hats, wide collars, and even short capes may be quickly manufactured from paper and the effect of the impromptu costume is marvelously good.

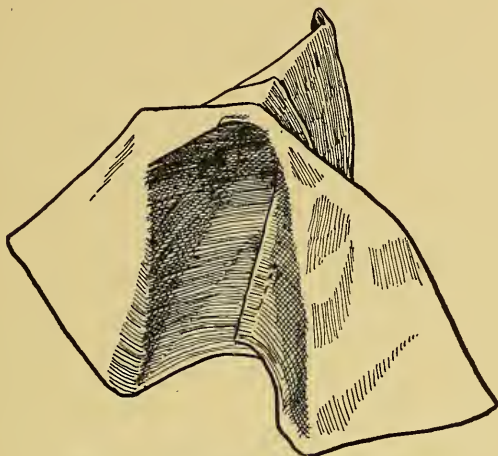

Fig. 7.—A most becoming newspaper bonnet.

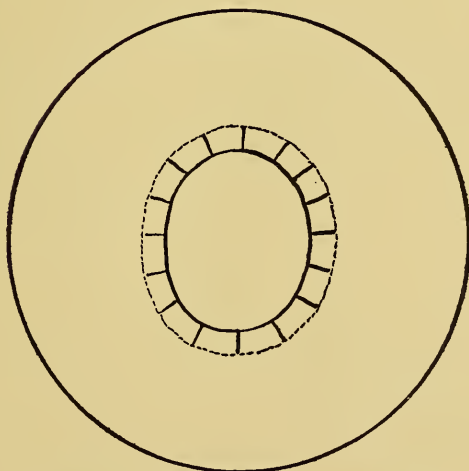

Fig. 8.—Cut the boys' hat brims like this.

### **The Shuffle Race,**

next in order, is new and it is funny. Its requisites are, for the girls, short skirts, held well above the ankles, and low shoes or slippers many times too large, worn over ordinary shoes. Unless the foot can be lifted out of the shoe without touching it with the hands the shoe is too small. For the boys you must provide the largest sized slippers obtainable, having uppers only at the toes.

The course should be about one hundred feet over a smoothly shaven lawn. The contestants must stand in line at the starting point and at the word "go," start off on the race, shuffling along as fast as possible. The boys have no advantage over the girls in this game, for it is no easier for one to cover the distance quickly, shuffling along in the large shoes, than for the other, and both look equally ridiculous in their absurdly frantic efforts to win the race.

After resting from the shuffle race allow your guests to try their skill at

### **Hurling the Lance.**

From the limb of a tree have suspended five or six feet from the ground a small wooden hoop, about eighteen inches in diameter, covered like a drumhead with white tissue paper.

Provide each player with a round, green, tapering stake, white tipped and five feet long—the kind used for propping up plants. On the blunt end of each stake, or lance, should be tied streamers of red, white, and blue, which will make streaks of color as they are sent hurtling through the air.

Clear the space on the far side of the hoop that no one may be hurt by the falling lances, then have each player in turn throw



Hurrying Along in the Shuffle Race.





his or her lance with the object of piercing the paper and sending the lance entirely through the ring. Each player may have three trials in succession, and unless her lance passes through the hoop at least once she is counted out. There are three rounds and the player wins who, at the end, has succeeded most frequently in sending her lance through the hoop.

Let the farewell be a

### **Burst of Daylight Fireworks.**

Strings of firecrackers stretched from tree to tree, bunches hidden under barrels, harmless torpedoes for your guests to explode, and any other fireworks that do not need darkness for a background may be used.

It is a good idea to make

### **The Balloon Ascension**

an especial feature of the display. In the early days of our country "Independence Day" was not to be thought of without a balloon ascension, and the time-honored custom may be observed, but in a new way. This part of the programme should come as a complete surprise, and all the preparation for it be kept secret, that none of your guests may suspect what you have in store for them. The old observances always included a patriotic speech, and that, too, should form a part of the ceremony, being used as an introduction to the balloon ascension. You may make the speech yourself or get some one to do it for you, but in either case let it be quite short. Balloons should not be mentioned, but in some way the old Grecian myth of Pandora and her wonderful box must be brought in.

### The Myth

can be used quite appropriately and effectively for, as you will remember, it was to punish Prometheus, and mankind in general, for stealing fire that Zeus commanded Hephæstus to form from earth this most beautiful Pandora, in order that by the charms with which the other gods endowed her, she might bring trouble and vexation upon them. It does not appear to have been altogether her charms, however, that worked the mischief, for we are told it was curiosity that induced her to open the box, or cask, which was filled with winged blessings for men, thus allowing all of the blessings except hope to escape. As the remarks are being brought to a close have your

### Pandora Box

carried out and placed in front of the speaker.

In this case the box is to be a good-sized sugar-barrel, wrapped in flags, or red, white, and blue bunting, and having a lid that is easily lifted. With the final words let the speaker step forward and suddenly raise the lid of the barrel. This will set free not the things that were in the original Pandora box, but a number of gas-filled, rubber, toy balloons, that will burst out like a volley of fireworks, for a moment filling the air with color and movement, then sailing upward and away to finally disappear from view in the blue sky overhead.

In preparing your Pandora box choose a barrel that is perfectly smooth inside, without long splinters or nails to pierce the fragile balloons. Then see that the cover has a handle or knob by which it can be lifted. A spool fastened on with a screw will serve very well and is easily grasped by the hand.

### **The Balloons**

are the kind one sees for sale on the streets tied in great bunches by their long strings. Red is the most common color, but sometimes they vary. Frequently there are white ones with red or yellow lettering and bands, and again, just before the Fourth, red, white, and blue ones may be found. Have all the colors possible, and crowd in as many as the barrel will hold, cutting the strings off close to the balloons that they may not become entangled, and taking great care that they do not escape, like the blessings, before their time.



—CIRCUS—

THE MODERN TRIUMPH

CONTINUOUS PERFORMANCES—NOVEL FEATURES

MADemoiselle ROSEBUD

—IN HER—

THRILLING AND DARING HORSEBACK FEATS

UNPARALLELED TRICKS

—OF—

BOB, THE TRAINED ELEPHANT

COME AND SEE == FUN FOR ALL

DON'T MISS THE SHOW

## CHAPTER II

### A WONDERFUL CIRCUS AT HOME WITH MOVING ANI- MALS



MAKE your poster as nearly as possible like the one on the opposite page. Paint the lettering in gay colors on a big sheet of paper and a day before the show tack it up in a conspicuous place where all the family will see it, for, of course, your show must have an audience, and if you follow out all directions very carefully it will be well worth seeing.

Have your circus on top of a large table, or on the floor, or out of doors on the bare ground. Almost any place will do where there is a good-sized level surface.

Make the circus ring about forty inches in diameter, outline it with chalk and cover the marked line with either sawdust or dry corn meal built into a narrow ridge similar to that of earth around the large rings; then your circle will look just like the ring of a real circus.

Be sure to have some kind of music at your show, if only music on a comb. Place a piece of paper over the comb and play a lively march. Let all the music be sprightly and gay.

Following the method given for making the horse and elephant, you can make various other moving animals.

Fig. 9 shows

### Mademoiselle Rosebud

standing firm and upright without the slightest tremor as her Kentucky charger leaps high in the air over an outstretched banner.



Fig. 9.—Making the high jump.

Fig. 10 gives the pattern of the horse and rider, which you can trace on stiff cardboard, not too heavy. If enlarged to twice the size given they will be more imposing, but this is not necessary, as the size of pattern is very good.

When outlined cut out the design, let the horse remain white, and with pen and ink draw the lines which give him form, shaping the head and neck, and separating the legs, as in Fig. 9.

Paint Mademoiselle's face, arms, and neck flesh color; her waist, skirt, stockings, and slippers light blue; make a full double tissue-



Fig. 10.—Pattern of horse and rider.

paper skirt of the same color by gathering a strip of light-blue tissue paper through the lengthwise centre, folding the edges together and tying this double skirt around the little lady's waist. Cut a narrow strip of the same blue paper and fasten one end

around each wrist that it may float freely in the air as she gallops around the ring.

### **To Give the Horse Ability to Move,**

pierce four holes through the body with a large needle, as in Fig. 10. Be sure to have the holes in the right places that the horse may balance perfectly; then when the threads are in position there will be no difficulty in making the horse stand and walk alone, as a well-trained steed should.

Use four pieces of strong black thread, all of the same length, about forty inches, for leading the horse. Tie all four ends of the thread together, and make a large knot in each strand seventeen inches from the joined ends. Run each thread through a separate hole in the body of the horse. Slide the horse against the knots tied in the thread and then tie a second knot in each thread close up to the other side of the horse.

Be very particular about these knots; they should rest against the body of the horse, that the animal may be firmly inserted between eight knots, four knots tight up against each side of his body. Sew a tag of black tape on the thread where the ends are tied together and pin the tag down to the floor in the centre of the circus ring.

### **Tie the Ends**

E and F (Fig. 11) together and fasten them to a piece of paste-board; do likewise with the ends of the threads G and H, then hold the two threads which are near the front of the horse, E and F (Fig. 11), in one hand and the other two threads, G and H, in the other hand while you walk slowly around the outside of the ring, allowing little Rosebud to ride demurely around in a circle, as such performers always do when they first enter a real circus ring.



After the audience has been duly impressed by the novel sight of a paper horse and rider moving, apparently without aid, around the ring, the black threads being practically invisible, let the horse stand alone while you bring out two or three brightly colored



Fig. 11.—Threads showing how to make the horse dance.

tissue-paper banners, with each end of each scarf pasted on the top of a spool. Place the banners at various distances around the ring; then again take up the threads and

### **Make the Horse Run and Jump Over Each Banner.**

This done, remove the banners and let the horse with his pretty rider dance around the ring, sometimes on his hind feet, as in

Fig. 12, and again on his fore feet (Fig. 11), while little Rosebud easily retains her footing, looking more than ever like a real circus rider.

Fig. 13 gives the different parts of

### **Bob the Wonderful Elephant.**

Make them all of stiff cardboard and larger if possible than the diagram; then with pen and ink draw the ears, eyes, and tusks

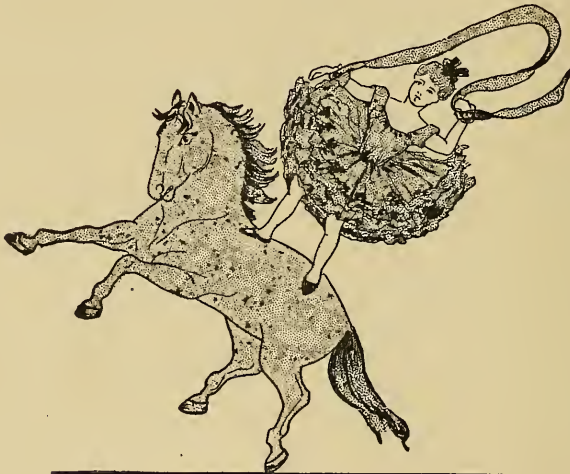

Fig. 12.—Horse and rider dancing around the ring.

(Fig. 14); waterproof drawing ink is best for this purpose, but common ink will do. When the ink is dry give all parts, except the tusks, a light wash of India ink, to turn the animal a natural dull gray color. With black thread fasten the leg A on the far side of the elephant, running the thread through the hole A in the elephant and tying the thread into a large knot on the leg, then making another knot on the near side of the body; the leg



Fig. 13.—Pattern of Bob the elephant.

and body are fastened to each other in this way between two knots of thread. Have the pieces close together, but loose enough to allow the leg to move easily. Attach the next leg, B, on the near side of the body at the hole B. The leg C goes on the far side of the body at the hole C, and the leg D on the near side at the hole D. The legs A and C are on the far side, and B and D on the near side of the animal (Fig. 14). Sew one end each of two

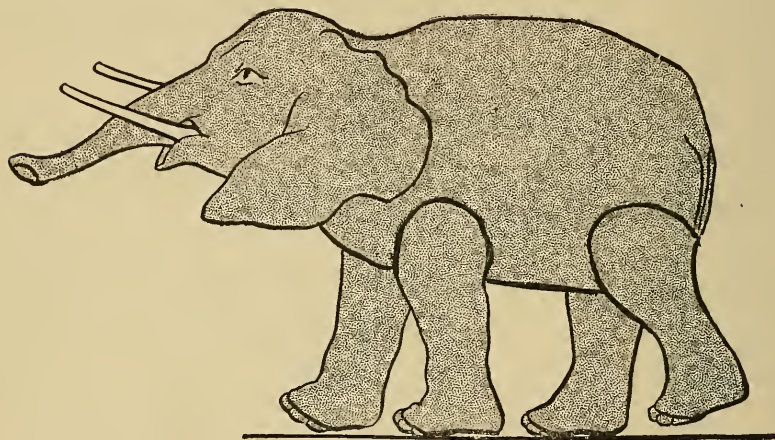

Fig. 14.—“I’ll walk.”

strands of black thread to a small piece of black tape. Make a large knot in each thread, eighteen inches from the tape, run the free end of each thread through one of the two holes high on the elephant’s body (Fig. 13), and slide the elephant on the threads close to the knots. Make other knots on this side of the body, in the same way you managed the Kentucky charger, then pin the tape to the centre of the ring and

#### **Start Your Elephant on a Walk**

around the ring.

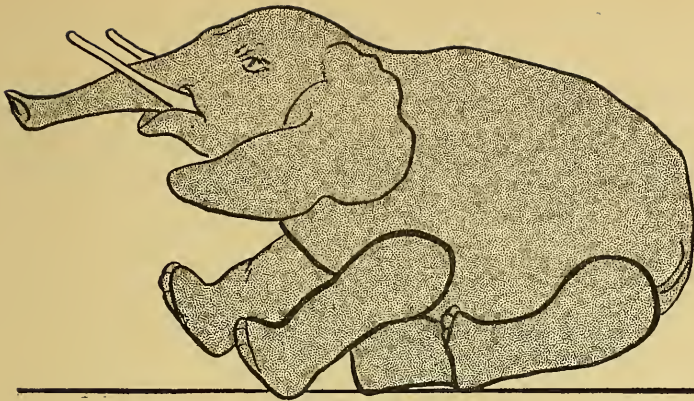

Fig. 15.—“Won't go another step.”



Fig. 16.—“See me sit up.”

If the horse and rider interfere, take them away and let the unparalleled animal have the field to himself. When Bob goes around the ring he always gets tired and draws back, declining to

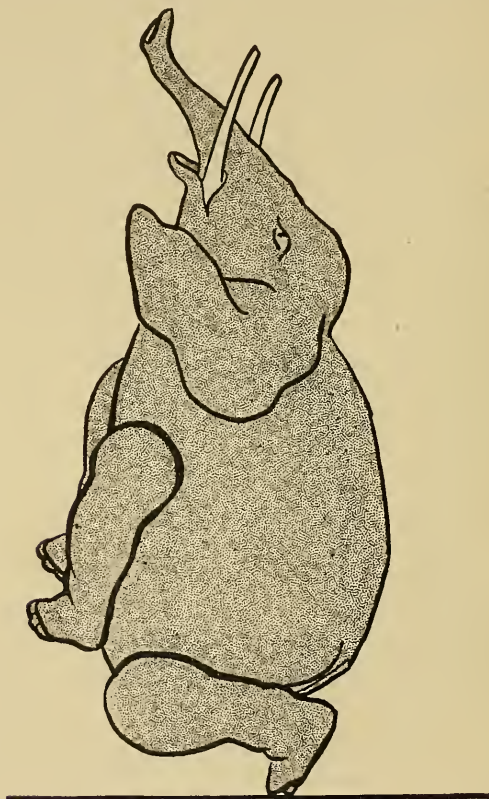

Fig. 17.—“I can dance.”

move another step. Make him do this by gently pulling the back thread backward. Bob is very comical when assuming this pose (Fig. 15). Raise the front thread and the little fellow will sit up

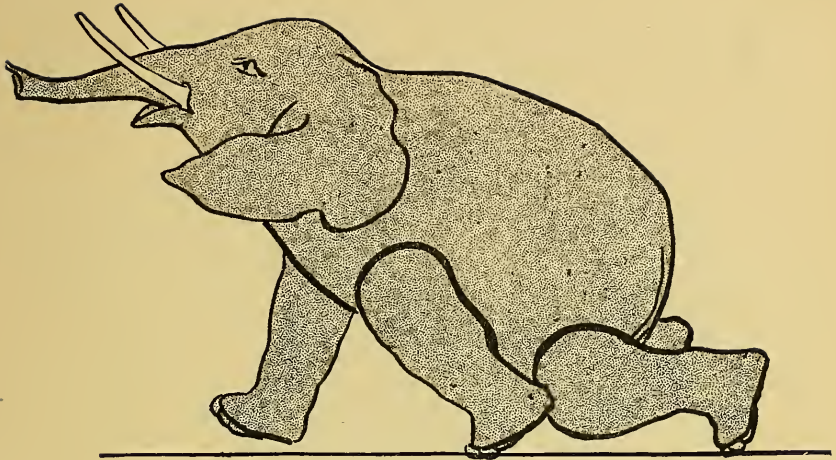

Fig. 18.—“I am coming.”

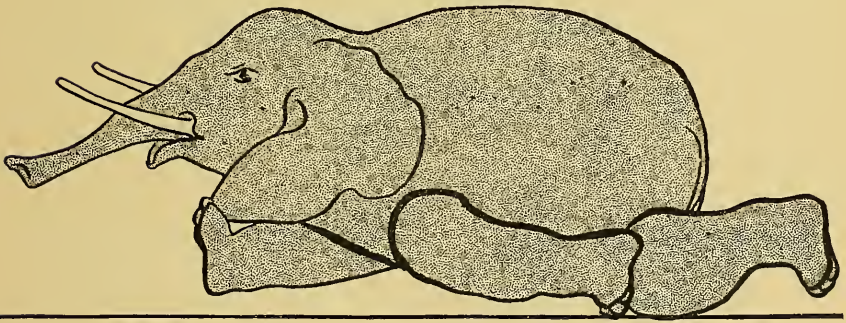

Fig. 19.—“Hurry! Get out of the way.”



Fig. 20.—“Here goes.”



(Fig. 16). Slowly and gently raise both threads a trifle and Bob will begin to dance (Fig. 17). Raising the back thread a little, not enough to take his foot from the ground, and at the same

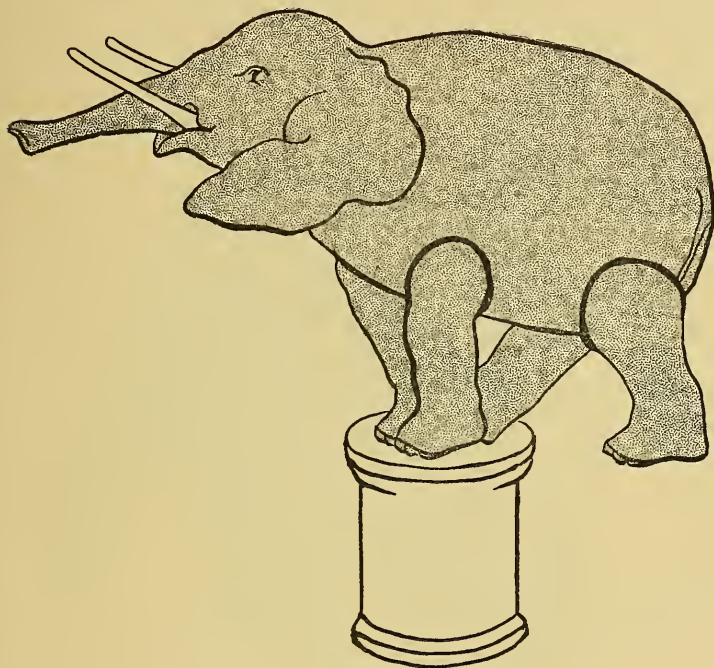

Fig. 21.—“How is that?”

time lowering the front thread, will cause Bob to crouch and crawl along (Fig. 18). Fig. 19 shows Bob when he is in a hurry. Make this by lowering the front thread of Fig. 18.

### Now Stand a Spool in the Ring

raise the clumsy little fellow up on his feet and walk him over to the spool, where he will naturally rest one foot on top while he takes a long breath before climbing up (Fig. 20). Move the threads carefully and the elephant will climb on the spool (Fig. 21). Lift

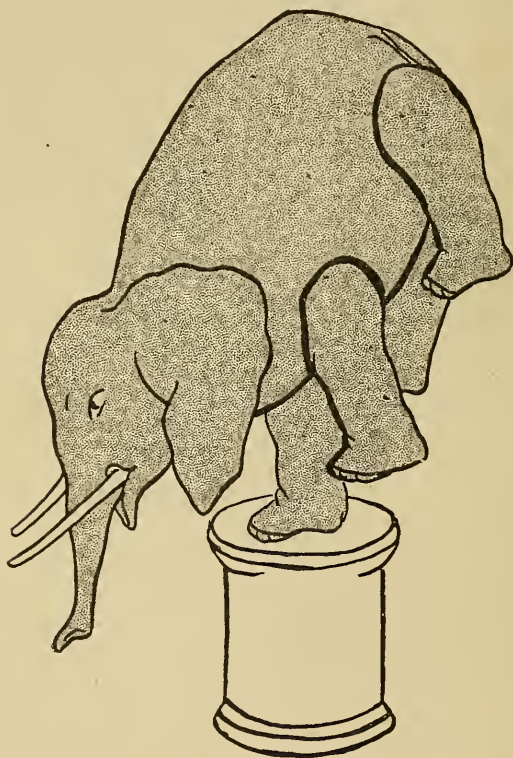

Fig. 22.—“Difficult, but I can do it.”

the back thread, and Bob will slowly and cumberously raise up until he balances himself on one fore foot on top of the spool (Fig. 22). By cautiously moving the threads you can make the elephant lower himself and step down and off (Fig. 23). When the animal is entirely off the spool, raise up and back the front

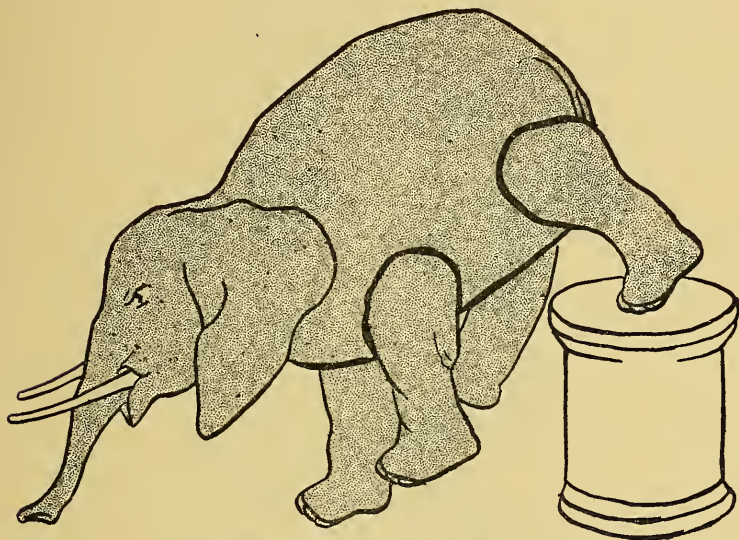

Fig. 23.—“I'm coming down.”

thread and he will sit down upon the top of the spool to rest (Fig. 24). Without any trouble Bob can stand erect on the spool, as in Fig. 25.

All the poses given were taken direct from those actually assumed by Bob while he performed to the accompaniment of music, when rehearsing to a small but appreciative audience, preparatory to appearing before the public in print. The Kentucky charger also went through all his acts to the same music.

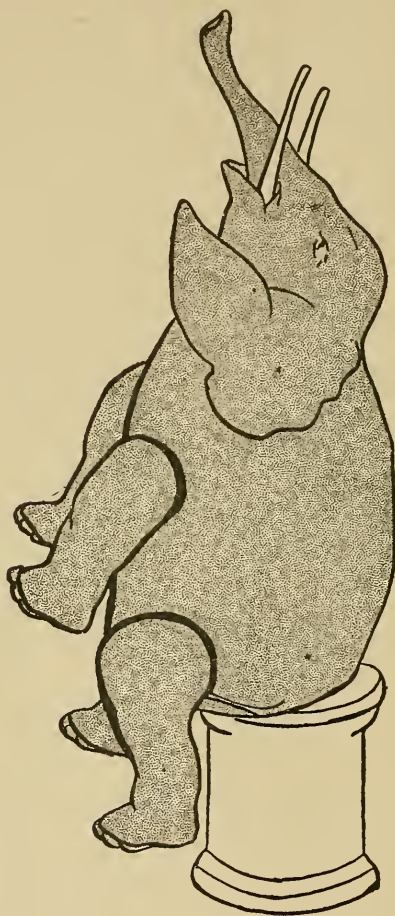

Fig. 24.—“Must rest.”

Remember to mark and color the wrong side of each figure as it should appear, so that the animals and rider may look well from all sides of the ring.

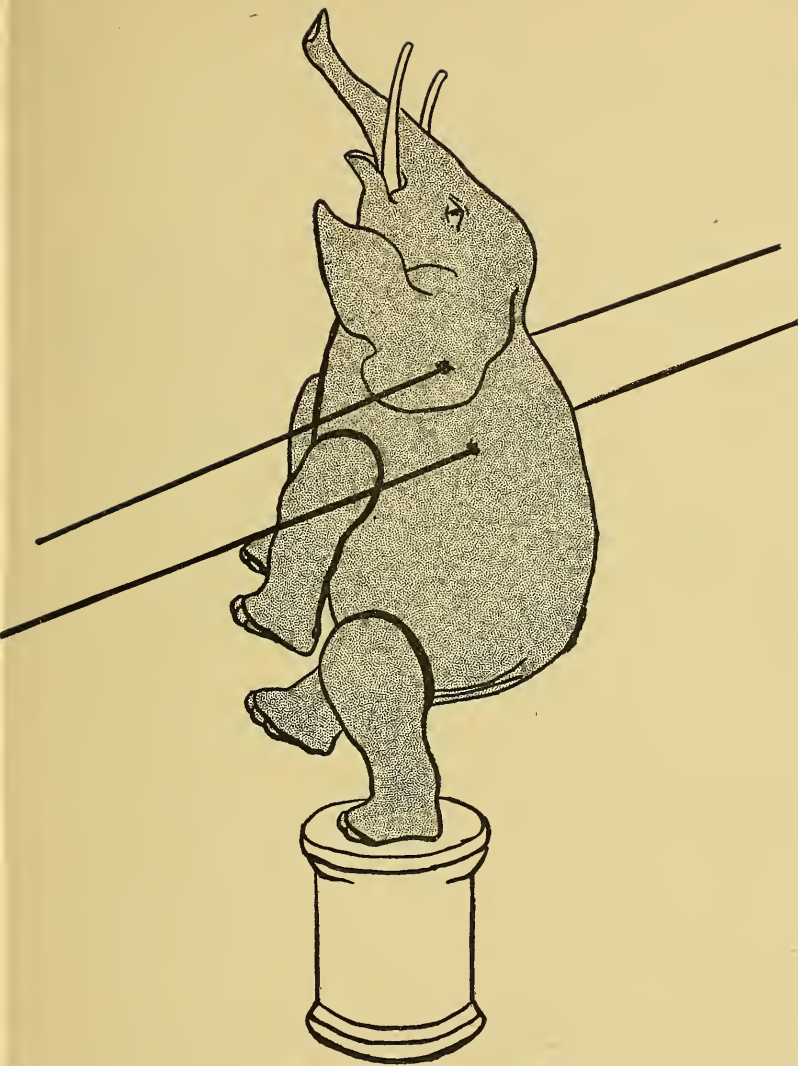

Fig. 25.—“ Just balance like me.”

The horse can go rapidly, but the elephant, to be lifelike, must move slowly. When the circus is over roll the threads on their respective pieces of cardboard and bits of tape to avoid tangling them, and have a box ready in which the animals may lie flat until again needed.

This little circus will make a fine parlor entertainment, or would do admirably as a side show at your next fair, when a small extra admission could be charged and wee glasses of lemonade and tiny popcorn balls passed around to the audience in true circus style.

## CHAPTER III

### A NOVEL EASTER PARTY WITH NEW EASTER GAMES



HERE are no end of delightful things to do at an Easter party, and every game may be in keeping with the season.

The game of

#### Egg Tennis

is particularly pretty. As you play this new Easter game, showers of color will fill the air, sometimes descending in sparkling bits of orange, again reds, then greens or blues, yellows or purples, with all their beautiful tints. Quivering and shimmering, down the colored rain will fall, lightly covering your hair, clothing, and surrounding objects, while you stand, racket in hand, watching the result of your stroke. Your companions, seeing your success, will be eager to try their skill, also, with one of the pretty magic eggs. These colored showers do not even look wet, and they will not injure the most delicate of fabrics, for they are composed of countless bits of bright tissue paper.

#### The Number of Eggs

needed for the game depends upon the number of players. There should be three eggs provided for every two players. In case the first player succeeds in breaking two eggs in succession, the

third egg will not be used during the game, but may do duty at another time in another game. Should the first player fail in breaking the second egg, then all three eggs will be required.

### How to Prepare the Eggs

Select eggs as nearly of a size as possible; take one egg at a time and with a very coarse needle carefully bore a hole in each end by pressing the point of the needle against the shell and then turning the needle around and around until a little hole appears. Be very careful when boring not to press the needle with too great a force, as there is danger in so doing of cracking the shell and rendering it useless. When both holes are made, increase the hole on the large end of the egg until it is about as large around as the head of a common hat-pin (Fig. 26), then place the small end to your lips and blow out the contents.

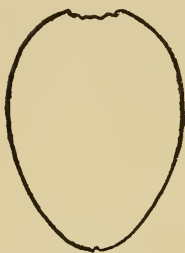

Fig. 26.—Carefully bore a hole in each end of the shell.

### After the Shells Are Emptied

leave one white and color all the others, making each shell of a different color. When this is done, allow the inside of the shells to become thoroughly dry; then fill them with pieces of tissue paper cut in small squares a quarter of an inch or less in size. These can be quickly made by folding the tissue paper like Fig. 27 and cutting it into strips of fringe (Fig. 28); then cutting off the ends of the fringe little by

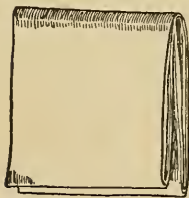

Fig. 27.—Fold the paper like this.

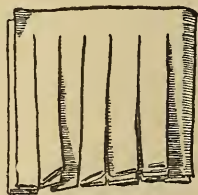

Fig. 28.—Cut the paper in fringe like this.





Playing the New Easter Game of Egg Tennis

little (Fig. 29). Fill the red egg-shell with bits of red paper, the yellow shell with yellow paper, and so on, making



Fig. 29.—Cut off the ends of the fringe.

### The Shower of Paper

in each egg-shell correspond to the color of the shell. Fill the white shell with squares of white tissue paper, and when the shell breaks in mid-air, the shower will resemble the dainty petals of cherry blossoms as they fall when shaken from the trees by a light breeze. The effect is very pretty, calling to mind the Feast of Cherry Blossoms in Japan, when the girls and boys accompany their elders to see the cherry trees in full bloom.



Fig. 30.—Gilt paper disk.

### Cut Gilt Paper Disks

two inches in diameter (Fig. 30); fold each disk through the centre (Fig. 31), then fold again crosswise through the middle of the first fold (Fig. 32). Fold once more (Fig. 33), and, following the dotted lines on Fig. 33, cut the points as shown in Fig. 34 and you will have



Fig. 31.—Fold the disk through the centre.



Fig. 32.—Fold the disk a second time.



Fig. 33.—Fold once more.



Fig. 34.—Cut out the point.

the eight-pointed star (Fig. 35). While the point is still folded with a sharp pair of scissors clip off the point (A, Fig. 34). This makes the hole in the centre of the star (B, Fig. 35). Through the hole in each star thread the two ends of a strong string. Cover the under side of the star with paste, separate the two ends of the string and hold them down on each side of the egg (Fig. 36), then draw the star down on to the shell over the strings, and press tightly in place until the paste holds (Fig. 37). Clip off the ends of the string that extend below the star.

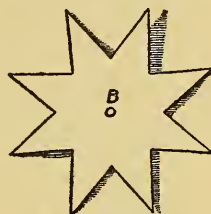

Fig. 35.—The star unfolded.

When the paste is quite dry and the paper firmly attached to the shell,

### Hang One of the Eggs

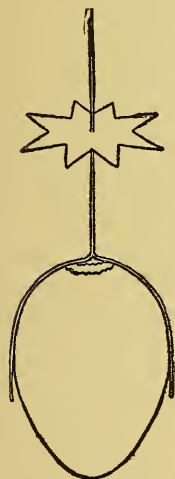

Fig. 36.—Hold the two ends of the string down on each side of the egg.

directly in the middle of a wide doorway so that the egg will be about as high as the shoulders of the players. If there is a curtain pole in the doorway tie the string to the pole; if not, drive a tack on top of the door frame and suspend the egg from that. Where the doorway is quite wide, like the old-fashioned doors between two parlors, two eggs may be hung and four players take part at one time. In that case you will need four rackets; ordinarily two rackets are sufficient.



Fig. 37.—Draw the star down and press tightly in place.

**Make the Rackets**

of flat rattan, taking two pieces, twenty-seven inches long for each racket. Soak the rattan to make it pliable, then bind the two pieces together with string as in Fig. 38. Bend the now double

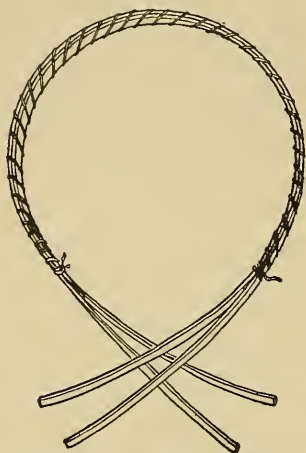

Fig. 38.—Bind the two pieces of rattan together.

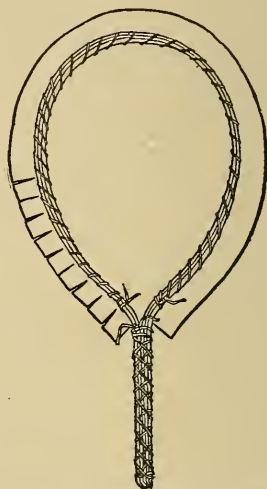

Fig. 39.—Bring the four ends together to form a loop.

rattan to form a loop, bring the four ends together and wrap them into a straight piece for the handle (Fig. 39).

Lay the frame you have just made down on a large piece of strong writing-paper and mark a line on the paper one inch from and entirely surrounding the outer edge of the frame down to the handle. Draw another line close to the outer edge of the frame, then cut out the design along the outside line. Slash the edge up to, but not across, the remaining pencil line (Fig. 39). Cover one side of the slashed border with paste or glue, and, again placing the frame on the paper, turn the flaps, one at a

time, over the edge of the frame and attach them firmly to the frame and to the inside of the paper (Fig. 40). When the paste is perfectly dry, make another paper cover in the same manner and paste its slashed edge over the frame on top of the first, putting one cover directly over the other and so making it double; this will make the racket quite strong and firm.

Wind a strip of paper one-half an inch wide around the handle, pasting it as you wind, and turn the end of the paper up

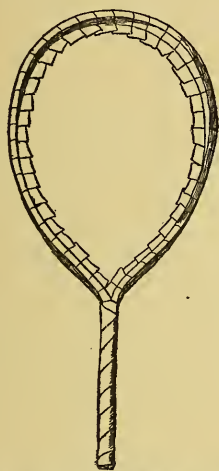

Fig. 40.—Turn the flaps of the border over the edge of the frame.

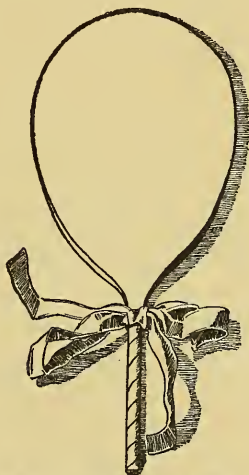

Fig. 41.—Finish with a bow of ribbon.

over the end of the handle (Fig. 40). Finish with a bow of ribbon, tying it on where the handle joins the racket. Fig. 41 shows the completed racket right side up.

### The Game of Egg Tennis

is played in couples, and the object is to break the egg-shell and send the paper rain flying in the air. The sport is adapted to

all ages, from the little child scarcely large enough to wield the racket to grown girls and boys, and even older people will become excited as they try to strike the fragile toy.

The players must stand facing each other at equal distances from and on opposite sides of the suspended egg. The distance is decided by swinging the egg and then placing the players within easy reach of it before it swings above their heads. This is done by the umpire, who takes charge of the game and decides any disputes.

Promptly at the signal,

**“Ready,”**

given distinctly by the umpire, the player who has been appointed starter gently swings the egg outward toward her opponent, and the egg is then “in play.” The other player immediately tries to strike the egg with her racket, using sufficient force to break the shell or send it flying swiftly toward the first player, who in turn promptly hits or misses the egg. Whether struck or not, the egg will return to the other player, who will surely be able to strike it the second time it comes to her, if not the first. And so the egg is kept swinging rapidly back and forth between the two players until the shell is broken. With the breaking of the shell comes the beautiful shower of tissue paper which is sent flying through the room by the stroke, and the player who releases it wins a point in the game.

#### **When the First Egg is Broken**

a second one must be put in its place, and the unsuccessful contestant has another opportunity to make good her record, playing with the same opponent. If the breaking of the second egg proves a tie—that is, if it is broken by the player who was at first unsuccessful—a third egg must be suspended and the same

couple continue to play until that, too, is broken. Then the unsuccessful player drops out of the game, and the winner of two points to his opponent's one steps aside to await his final play after the other couples have had their turn. Should one player win two points in succession the third is not played, for two points lost sends a player out of the game.

When all the couples have played, the successful competitors alone remain in the game. These form new couples and play as before, each in his order. This time there is but one egg for each couple, and the player who fails to break the shell must withdraw, giving his place to the next player, while the successful one holds his place until another breaks the egg. In this way but one player comes out victorious.

When space allows two eggs to be hung in the doorway and two couples take part at the same time, there must be two umpires, one for each couple, for in the excitement of the fray, one person cannot watch all the play.

#### RULES OF THE GAME

1. The umpire may not take part in the game while acting as umpire. She shall keep tally and decide all questions which arise regarding the game.
2. The egg shall not be struck except with the flat face of the racket.
3. When an egg is broken by striking against the surrounding woodwork, or in any other manner other than with the face of the racket, it counts one against the player who made the stroke and scores one for his opponent.
4. Two points scored during one play declares the successful competitor the victor.
5. A play consists of any number of trials until the two eggs are broken.
6. Two eggs shall constitute a play when there is no tie; in case of a tie there shall be three eggs.

Butterflies as well as eggs are appropriate for Easter and the

### **Butterfly Game**

will come in well as second on your programme.

All the girls are butterflies in this game and all the boys are collectors. The collectors are stationed in different parts of the room and stand some distance, at least six feet, apart. They may not move their feet to step in any direction, but, standing in one spot, may reach out on all sides with their hands as they try to catch the butterflies flitting past them.

### **Each Butterfly**

must lift the skirt of her dress with both hands and move it back and forth as she flies among, around and between the collectors. This moving of skirts as mimic wings makes the game appear very pretty to the onlookers, and the collectors find it difficult to grasp the fluttering draperies.

### **It is the Part of Every Collector**

to catch as many butterflies as possible and as each butterfly is caught she must stand close behind the collector to whom she belongs. The second captive stands behind the first with her hands on the shoulders of number one. The third takes her place behind number two with her hands on the shoulders of number two and so on to

### **The Last Captive**

The game becomes exciting when but one free butterfly is left, darting about, skilfully evading the outstretched hands of the collectors, each intent upon capturing this last and greatly valued prize. For in the count the last butterfly captured is equal to two of the others.



The game ends when all are caught and the winner is he who possesses the greatest number of butterflies, counting the last one caught as two.

### **The Magic Dye Kettle**

will be a unique, amusing and mystifying feature in the entertainment of your guests. For this some preparation is necessary.

First you must have the tinsmith remove the bottom of a new, inexpensive, tin kettle, one that has a lid to fit and will hold several quarts. Then in the bottom of a square wooden box, about as large as a small table, have a hole cut a trifle smaller than the bottom of the kettle. Knock out one side of the box, stand it bottom side up so that the round hole will be on top, place it in the position it is to occupy, and throw over it some kind of a cover which will reach to the floor and hide the box completely on all sides. In this cover you must cut a hole to fit the hole in the box, and place the hole in the cover directly over the hole in the box. Place the lid on the kettle and stand the kettle over the hole and it will appear to be merely sitting on the table, as there will be nothing to indicate the opening beneath.

### **Under the Box,**

ready for use, place a shallow tin pan larger around than the bottom of the kettle, and cover the bottom of the pan with sawdust; also place under the box a basket filled with hard boiled eggs of various colors, three eggs of each color.

In another part of the room have ready another basket containing the same number of hard boiled eggs but all uncolored.

While the Butterfly game is in progress let some one who is in the

### **Secret of the Magic Kettle,**

hide under the improvised table and at a given signal lift the shallow pan and hold it tightly under the hole in the box.

Explain to your guests that you have for the occasion a magic kettle, which, while they wait, will color eggs for them without water and without heat. Pass around the basket of uncolored eggs and invite each one to take an egg. Tell three members of the party to decide upon a color they wish their eggs dyed (all three must be the same color) then, as you raise the lid, to shout the color in unison, and carefully place their eggs in the kettle.

As soon as the eggs are in quickly replace the lid and wave your hands back and forth over the kettle. Apparently you will be working a charm, but in reality you will be keeping the too curious from taking a peep into the kettle to see what process is going on.

When the uncolored

#### **Eggs are in the Kettle**

and the lid is on, your assistant underneath must gently and without the least noise lower the pan she is holding, and in which the eggs have been deposited, remove the uncolored eggs and substitute three others of the color she has heard wished for. Then lifting the pan she must again hold it close under the kettle until

#### **The Colored Eggs are Taken Out**

and three more put in to be dyed.

Give your assistant several minutes to make the exchange of eggs, then lift the lid and allow the eggs, so quickly and so marvellously colored, to be lifted out by their owners.

When all the eggs have been dyed lead your guests from the room without allowing any investigation of the workings of the magic kettle and while they are out have box, kettle and eggs taken away so that the charm of mystery may not be broken.

## CHAPTER IV

### A DOORWAY PUNCH AND JUDY SHOW

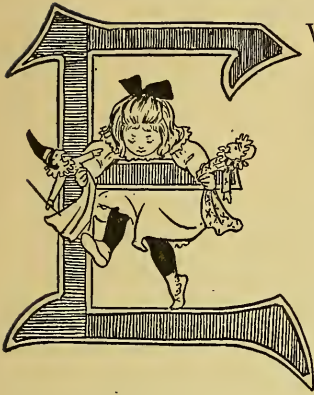

VERYBODY laughs when he sees Mr. Punch, with his funny long nose, and his wife Judy in her frilled cap. The show is all fun, every bit of it; even the little baby seems to understand and appears actually pleased when Punch and Judy toss him back and forth, as they might a rubber ball. When the infant happens to fall, he is never hurt; the accident is but a good joke and part of the sport.

One great charm about the show is, that you can make Punch and his family do exactly as you please and say exactly what you want them to say, for so long as you are showman they yield implicit obedience to your will.

The only material necessary for

#### The Stage

will be a piece of plain solid-colored cloth, which must reach across an open doorway, be tacked upon each side and extend down to the floor, where it should be again fastened that there may be no danger of its blowing aside. Put this curtain up high enough in the doorway to reach a trifle above your head, for you must be completely hidden from the audience. The full-page illustration shows the back of the stage and gives the manner in which Punch and his family are made to move about in

the opening between the top of the doorway and the curtain. It is this opening which constitutes the stage. The illustration also shows a band of cloth stretched across the extreme top of the doorway, and short side curtains added to the outside of the stage to improve its appearance.

### To Make Punch's Head,

cut a piece of unruled white writing-paper eight inches long and five inches wide, to allow a generous margin, and on it draw Fig.

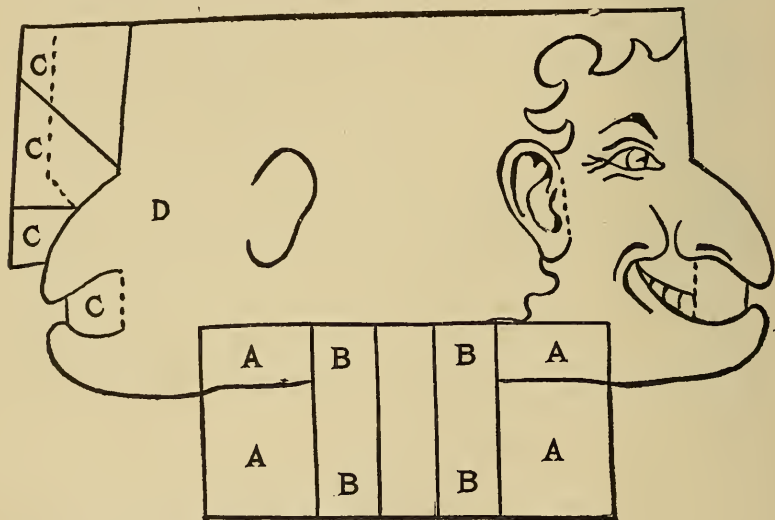

Fig. 42.—Draw Punch's head like this.

42, making the head 6 inches across one way and 4 inches the other. Paste a strip of thin cloth over the neck which includes the entire space between the four corners marked A-A-A-A, and over this cloth paste two more cloth strips in the spaces marked B-B and B-B. The cloth strengthens the neck and prevents it from tearing while the head is in motion. Carefully mark the



Behind the Scenes in the Doorway Punch and Judy Show.



features, copying them also on the right-hand side of the face (D). Cut out the head, including flaps, and the ears along their outer edge. Cut the line of the chin into each side of the neck as far as the second strips of cloth (B-B and B-B). Roll the neck until it fits loosely on your first finger, then paste it together like a ring. Paste the tips of each side of the nose together, also those of the chin.

Bend the flaps at the dotted line on the edge of the face and paste the other side of the face part way over the flaps, covering the spaces C-C-C-C. If the head seems too narrow, bend the paper out to make it appear wider. Roll an extra piece of writing-paper and fit it inside the head. Be sure that the roll lies evenly and is close up against the inside of the head; then bend out the ears, paste the paper lining in place and paint the entire head pink except the eyes and teeth. When the first color is dry, paint the markings on the ears red; the hair and eyebrows, markings for teeth and the eyes black; the lips, nose, chin and cheeks a brilliant red.

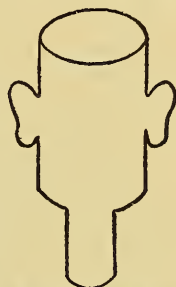

Fig. 43.—The top of his head is open.

The top of Punch's head is open (Fig. 43), but we will cover it with a high, pointed cap, and the uncovered space where the chin comes forward beyond the neck will not be noticed when Punch is dressed, for the double ruffle around his neck hides all deficiencies. Make each arm of a roll of writing-paper pasted together along the edge. The roll must be about four and three-quarter inches long. Flatten and paste together one end of each arm, and on these flat ends draw

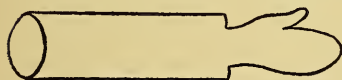

Fig. 44.—Make the hand in the shape of a mitten.

the outline of a mitten, which will serve as a hand; when the paste is dry, cut out the mitten (Fig. 44). Paint the hands and arms pink.

The arms should fit loosely over the ends of your thumb and forefinger. Fig. 45 gives the pattern of

### Punch's Dress

Make it much larger, according to the di-

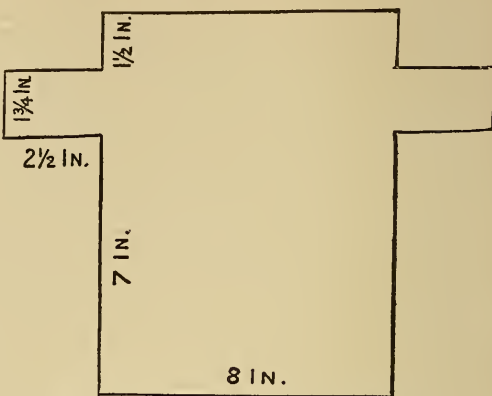

Fig. 45.—Cut Punch's dress after this pattern.



Fig. 46.—Your funny old Punch.

mensions given on patterns, and let it be of soft material in very bright, gay colors. The front and back are exactly alike, and the two pieces are sewed together at the sides, the seams extending to within two inches of the bottom of the skirt, leaving the sides split up that distance. Slide the paper arms up in the sleeves and fasten them in place at the top with a drop or two of glue. Make a wide, white double ruffle, slip it on Punch's neck and push it up against the head. Then gather the top of the dress so that it will fit Punch's neck, and fasten it on under the ruffle with strong glue, allowing the bottom of the paper neck to extend down below the gathered top of the dress. Make a high cap of brilliant red cloth to fit Punch's head; trim it with a



turned up band of vivid green edged with white and glue the cap to the head. With a stitch or two or an elastic band fasten an inked paper lighter in his right hand to serve as a stick.

Now slip the first finger of your left hand up in Punch's neck, run your thumb and second finger of the same hand in the paper arms, and make Punch turn and twist his head while he gesticulates with both arms. You will laugh before you know it, and be delighted with your funny old Punch (Fig. 46).

### Make Judy's Head

by the pattern used for the head of Punch, but omit the ears and cut off the ends of both nose and chin. They should not be so long for Judy. Strengthen the neck with cloth and fasten the head together as you did that of Punch. Make blond hair of two pieces of yellow tissue paper pasted in narrow irregular folds on the inside of the top opening of the head; then bring over and down on the outside as if combed loosely over Judy's ears. Paste the lower ends of the paper hair above the neck on the back of the head. Paint Judy's eyes blue. In all other respects than the details mentioned, make Judy's head the same as you did that of Punch. Make her arms and hands the same, the double ruffle for the neck



Fig. 47.—Judy will look like this.

the same, the dress the same cut but of contrasting color. Cut Judy's cap from thin white material, make it circular and gather it entirely around, about one inch from the edge. Attach strings of the same material, and tie them under Judy's chin (Fig. 47).

### **The Baby**

must be quite light in weight. Make it of a piece of pink tissue paper about eight inches square. Draw the paper through your hands several times to crush it into small folds, then, while it is crushed together, double at the middle and wind a thread around near the folded end to form a neck, leaving half an inch above for the head. Gather a piece of white tissue paper around the baby's neck to make its dress, and cut a straight strip of white tissue paper for the baby's cap. Lay it flat on top of the head and bring the two ends down straight on each side of the face. Gather the cap at the back, add strings and fasten it on the baby's head. Features may be marked on the face with paint, but be very careful not to use much water with the colors, for water will melt the tissue paper face.

### **When All is Ready**

slip Judy on one hand, Punch on the other hand, and make them talk and act to the best of your ability. Assume deep tones of voice when you talk for Punch, and high, shrill tones for Judy; make the play short, full of life and action, and as funny as possible. Of course, you will have to practise with Punch, Judy and the baby in front of a mirror before giving your show in order to see how they will look as you make them act, and to learn just how to manage them.

**Drama of Punch and Judy**

PUNCH (*below*): Wait a minute, sha'n't be long putting on my new boots (*pops up singing*). Trala-la-la-la-la-la-la. Hello, there! Watch me dance (*dances, singing a lively tune to music; music stops and he leans down, calls below*). JUDY! JUDY! JUDY, come here.

JUDY (*pops up*): Well, Mr. PUNCH; what do you want? I'm dreadfully busy just now.

PUNCH: Oh! nothing, only want to know if you'd like a box of French candy, the delicious kind that melts in your mouth; but never mind, I can get it for you next Christmas (*Punch turns his back and walks off*).

JUDY (*running after Punch*): Punchy-munchy, I wish I had it now; do, Punchy, give it to me.

PUNCH (*turning*): You must give me a kiss first (*they hug each other and have a merry time dancing and singing to lively music*).

JUDY: Oh! Oh! I forgot the baby. I'll go and get him (*disappears*).

PUNCH (*calling after her*): Well, hurry up, and don't forget our dog Toby (*calls*). Toby! Old dog Toby—come and jump over my stick (*bangs his stick about, striking everything, accidentally strikes his nose*). Oh! Oh! Oh! my poor nose, my best Sunday nose, my beautiful long nose (*calls*). JUDY! J-U-D-Y, where's the baby? (*Enter JUDY with baby*).

JUDY: Here, PUNCH; catch him (*tosses baby to PUNCH, who catches him; dances about, then tosses the baby back to JUDY, who fails to catch him*).

JUDY: PUNCH! PUNCH! Where's the baby?

PUNCH: Gone down-stairs. I'll fetch him up (*disappears*).

JUDY: Just think! the little dear went down-stairs all alone!

(PUNCH *reappears*.)

PUNCH: Here's the little darling; pity his nose is not longer. Do you think it will grow, JUDY? (*baby cries; PUNCH tosses him up in the air singing*). He didn't dance, dance, dance; he didn't dance all day nor yesterday.

(JUDY *tries to catch the baby*.)

PUNCH: Take him! Now we will both sing while I keep time with my stick. Begin, I say; quick, hurry, quick! (JUDY runs away with the baby while PUNCH is talking and not watching her; turning, PUNCH finds himself alone).

PUNCH (calls): Baby! Baby! Come and see your daddy's beautiful nose (baby is tossed up from below). See! See! my boy can fly through the air (knocks with his stick, then calls). JUDY! Why don't you come? (JUDY appears with baby, walks back and forth).

JUDY: I must get this child to sleep.

PUNCH: Nonsense, I'll amuse him (grabs child and disappears with him; baby heard crying, "Mama! I want my Mama!").

JUDY: Just listen to that (waves her arms frantically around and disappears.)

PUNCH (reappearing with a flag in each hand): We haven't given you our flag dance. JUDY! girl, come along.

JUDY (jumps up with a flag in each hand): Hush, PUNCH, you'll wake the baby.

PUNCH: Now let's dance. (The music plays and the two dance and sing some popular air, then together bow to the audience, saying:) Good-by little girls and boys, good-by, everybody. We've had such a good time. Good-by, good-by.

The flags may be of home or store manufacture, but they must be fastened on paper sticks, made like Punch's paper-lighter stick. They can all be American flags, or three other nations may be represented, or each flag can be of solid color, differing from all the others, as red, green, yellow and blue.

If a companion will help with the show by taking complete charge of Judy while you attend to Punch, the management will be much easier, for then you will have only one doll to make talk and act.

## CHAPTER V

### HALLOWE'EN MERRYMAKING

#### Novel Ways of Telling Fortunes



THIS year the annual festival of the fairies is to be celebrated with wilder pranks and madder mysteries than for many a long season, and if we enter heartily into the spirit of the fun and make preparations for them, the little folks will surely reveal many secrets the future holds in store for us.

Ask the fairies, gnomes and elves to your Hallowe'en frolic; they will be delighted to come, though of course, you cannot invite them in the usual fashion. Instead of writing notes, you must braid three

#### Invitation Rings of Grass—

fresh grass is best, but the dried will do—and hang the rings on bushes (Fig. 48), or lay them on the outside window-sill, making a wish on each grass ring as it is put into place. To insure the fulfilment of the wish, you must not see the rings again until after Hallowe'en. The fairy troupe will find the green circles as they come floating along through the air on gay-colored bub-

bles from the magic spring waters of Fairyland. During the last days of October fairies are always looking for such invitations.



Fig. 48.—Hang the rings on bushes.

Here are some of the ceremonies and games newly revealed to me by the old witch who lives in the black clouds that sail southward on the northwest wind.

### Black Cats,

the friends and companions of witches, are wonderful creatures to conjure with, but all cats can work a charm, and it is cats, or preferably kittens, you must have for the first rite. There must be a pussy in hiding for each girl

and boy present at the Hallowe'en frolic. With different colored bright ribbons tie a tinkling bell around the neck of every cat, leaving one end of the ribbon one yard long. Seat your Hallowe'en guests in a semicircle around the room. Ask them to sit quietly for a few moments, and suddenly put out the lights. With the room in total darkness let absolute stillness ensue for a second; then say very slowly and distinctly:

“Hold out your right hand and there will come to each one of you a disguised gnome or fairy. Be very gentle and kind to the little creature (here pause for a moment); for if by any



Beard

Kittens Telling Who Will be the First to Marry.





chance ill befall the disguised sprite the fairies will be angry and will do nothing for you until next Hallowe'en." Again pause; then say: "So I caution you once more—be kind and gentle."

Have some one keep the kittens near by, in readiness, so that you may lead all into the darkened room without a moment's delay. Hold the ends of the ribbons in one hand while with the other you take one ribbon at a time, and as you pass along the line place it in the outstretched hand of each successive guest, saying as you do so, "Hold fast this magic clue." The instant the last ribbon has been given to a guest, turn on the lights and while the girls and boys are looking with surprise at the little creature they hold captive and laughingly exchanging comments, you must pin a piece of white tape on the floor across one end of the room about four feet from the wall. Request the guests to kneel, with their funny little gnomes, in a row on the enclosed space next to the wall, and face the tape. Announce that there will now take place the race of fate. Each player must hold his or her pussy with its fore paws directly on the tape, and at a given signal all the girls and boys must exclaim in unison, "Run!" at the same time releasing the kittens that they may scamper away in any direction they choose. The guests should remain stationed back of the tape line and watch them as they scatter wildly over the room trailing their bright streamers. No one may touch or in any way molest a kitten after the signal has been given to let them go. The girl or boy whose pussy first reaches the centre of the room, which has previously been marked with a second strip of tape, will be the first to marry.

Do not wait for the other kittens to make the goal, but gather up the little creatures and lead them away to be seen no more, or the spell will be broken.

Old shoes possess strange and occult powers as we all know, else why should we throw them after the coach of a newly wedded couple? So we must have a

### Pair of Old Slippers

After the last cat has disappeared, bring out the slippers; any kind except toy ones will do. Place the slippers on a sheet of white paper laid on the top of a table where all present may see.

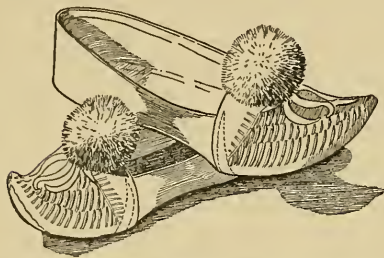

Fig. 49.—Place one slipper on top of the other.

Explain to the girls and boys that they must take one turn each in trying their fortunes by putting one slipper crosswise on top of the other, both right side up (Fig. 49),

and while holding them so, repeat the following verse:

These slippers I toss into the air.  
 Will my love be dark? Will my love be fair?  
 What future is mine? I pray you show  
 By the turning of sole or the pointing of toe!

Lift the paper and give the slippers a slight upward toss to fall on the floor as they may, and the manner in which they reach the floor indicates the fortune:

When both slippers land upside down and do not touch, the player will be a great traveller and have no settled home.

When both slippers land right side up and do not touch, the player will go on the stage.

When the right slipper is upside down, the future mate will be cross and selfish.

When the left slipper is upside down, the future mate will be unselfish and kind.

When the slippers are crossed there will be an early marriage.

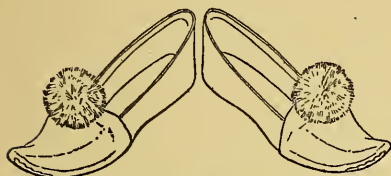

Fig. 50.—Decided difference of opinion between husband and wife.



Fig. 51.—Very congenial.

When the toes of the slippers point in opposite directions, there will be decided difference of opinion between husband and wife (Fig. 50).

When the toes of the slippers point in the same direction, husband and wife will be very congenial (Fig. 51).

When the soles cross, lying one on top of the other, the player will own a gold mine.

### Cups and Bowls

have supernatural power on this night and exercise a peculiar influence over marbles placed under them; consequently you must get three china cups and three marbles, a crystal (clear glass marble), a commie (ordinary brown marble), and a china (a white marble crossed by different colored lines).

Set three cups in a row (Fig. 52), under one place a "crystal," under another a "commie," and under the last a "china." Blind-fold each player in turn and let the girl or boy raise one of the cups. If the marble under the lifted cup is the crystal, the husband or wife will be young and life will be easy and full of sunshine. If it is the china, the husband or wife will be middle aged

and life will be hard but famous. If the commie, the husband or wife will be old, and life will be filled with adventure. The

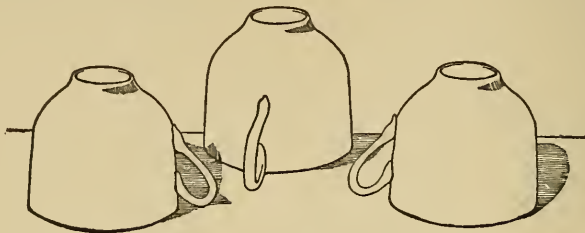

Fig. 52.—Set three cups in a row.

marbles must be changed into different cups after blindfolding each player.

As no Hallowe'en ceremonies are complete without

### The Apple,

there must be a dish of apples and a box of wooden toothpicks.

With the apples and toothpicks you can ascertain for your guests the nationality of their future mates.

Give every one an apple and a wooden toothpick. Each player may push the toothpick in any part of the apple; the spot

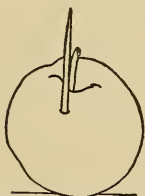

Fig. 53.—You will marry an American.



Fig. 54.—Your future partner will be English.



Fig. 55.—Your future mate will come from France.

occupied by the toothpick tells the fortune, but the apple must be kept in one position, and on no account turned after the toothpick is once in. When all have inserted the toothpicks

each boy and girl in turn must hold up his or her apple that all may see while you read the fortune.

When the toothpick stands straight and erect in the top of the apple, the life partner will be an American (Fig. 53); if in the left side of the apple, the mate will be English (Fig. 54); in the right side, French (Fig. 55), in the back, German; in the front, Italian; sideways at the top of the apple, the mate will be a West Indian; sideways in the right side, the mate will be a Japanese; in the left side, a Russian; in the front, Spanish. When the toothpick breaks the player will not marry.

Now comes the fun of forecasting to learn where the wedding will take place, so prepare for

**The Wedding Race**

For this you must have a card like Fig. 56; fill in the spaces under "The way you go" with the following words according to the numbers: (1) Walk slowly, (2) Walk backward, (3) Walk on toes, (4) Walk on heels, (5) Run, (6) Walk fast, (7) Skip, (8) Walk without raising feet, (9) Run on toes, (10) Walk on toes of one foot and the heel of the other, (11) Run on heels, (12) Walk sideways.

In the spaces under "Wedding" insert: (1) Church, (2) On shipboard, (3) Boarding

INITIALS	Nº	THE WAY YOU GO	WEDDING
	1		
	2		
	3		
	4		
	5		
	6		
	7		
	8		
	9		
	10		
	11		
	12		

Fig. 56.—You must prepare a card like this for the Wedding Race.

house, (4) Hotel, (5) Home, (6) Friend's home, (7) Top of mountain, (8) Minister's house, (9) Tent, (10) Out of Doors, (11) Courthouse, (12) Cave. Inform the guests that each in turn must go the length of the room. He or she may walk slowly, walk fast, walk sideways, walk backward, walk on toes, walk on heels, walk on the toes of one foot and the heel of the other, etc., etc.

If many guests are present, start two at a time crossing the room, one from each end. Write the initial of every player on the line of the card corresponding to the manner in which he or she crosses the room; for example, if the first player's name is Barbara Carter, and she runs across the room, put down her initials B. C. on the line No. 5 on which is written the word "Run." If the second player's name is Jamie Bartlett and he also runs write his initials J. B. on the same line of the card, but, should Jamie decide to go backward across the room his initials would then belong on line No. 2. When all the girls and boys have crossed the room, and quiet again reigns, read to them the various places where the different players will be married, for instance, if referring to your card you find the initials of Jessie Douglass on line No. 12, you should read, "Because Jessie Douglass walked sideways across the room, she will be married in a cave. Won't that be romantic?" Always add some pleasant remark after reading each record; such remarks make things run easier and add to the fun. Probably you will be able to think of many delightful little speeches, but in case you find any difficulty, the following list may be of some assistance. Remark for line No. 1: There could not be a better place. No. 2, How charming. No. 3, Better there than not at all. No. 4, I wonder if that will be a runaway match. No. 5, The dearest spot on earth. No. 6, A friend in need is a friend indeed. No. 7, I



The Vesper Rite.





hope we will all be invited. No. 8, An elopement, you may be certain. No. 9, Delightful. So gypsy-like. No. 10, I am sure there will be room for us all at this wedding. No. 11, Many a happy marriage has taken place in a court-house. No. 12, Won't that be romantic?

The communicative old witch of the northwest wind imparted so many methods of Hallowe'en fortune telling you can take your choice. Here are the rest just as she told them.

### **The Vesper Rite,**

if observed with due solemnity, will disclose the principal characteristics of any one submitting to the test.

Take six large potatoes and cut them in half. Shape each half into a candlestick by scooping out a round hole in the small end, making it large enough to hold a candle.

Place a half candle in each of the potato candlesticks and pin around each candle a strip of paper on which is written one word indicating a trait of character, such as "modesty," "bashfulness," "vanity," etc.

Then form a magic ring of the candles in the centre of a dimly lighted room. The ring should be about three feet in diameter.

Blindfold one of the players and have the entire party join hands and run three times around the lighted candles.

Then, leaving the blindfolded player standing two feet from and facing the ring, let the others fall back while a chair is placed before her, a fan is handed to her and she is told to make three trials at fanning out the candles over the back of the chair.

After the third trial she must remove the bandage from her eyes and examine the papers on the candles that are left burning, reading aloud the words which reveal her character.

To avoid any danger of skirts catching fire, care must be taken that no one approaches the candles too closely after they are lighted.

Another game is called the

### Bean Bag Test

Into a bag that will hold four or five quarts, pour three quarts of dried beans and in their midst hide a ring, a thimble and a brass button.

Have ready a bright new tin cup and let each player in turn dip into the bag and take out a cupful of beans which must be emptied into a plate.

If either a girl or boy finds the ring in the beans it is a sign of an early marriage. If a girl gets the thimble she will be an old maid, and when the thimble falls to the lot of a boy he will marry an old maid.

The brass button in a girl's cup of beans denotes that she will marry a widower, but in a boy's cup it is a bachelor's button and shows that he will be a bachelor all his life and will sew on his buttons himself.

Each player can have but one trial, and if only beans fall to her share, it signifies that her fate is still undecided.

Here is another test called

### The Witch Screen

Across the end or corner of the room fasten a breadth of inexpensive cloth for the witch screen; old muslin or any material most convenient will answer the purpose if not too thin. Through the lengthwise centre of the cloth cut two slits for each player.

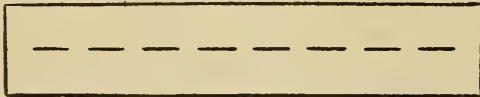

Fig. 57.—Through the lengthwise centre of the cloth cut two slits for each player.

slits for each player. Fig. 57 has eight slits and is intended for four players. Seat the company in a row near to and facing the witch screen, adjust it so that the slits will come on a level with the hands of the players, then, standing behind the screen and looking over the top, say, "I have some wonderful treasures which the witches have loaned us for this evening, but, as the objects are very valuable and must be returned, I ask that you use the utmost caution in handling them, and take great care not to drop or break any of the things while passing them from one to another down the line.

"The first charm is

#### A Piece of Lava

brought from Mt. Pelee in a witch's pocket (Fig. 58). If you will all kindly slip both of your hands through openings in the witch screen (Fig. 59), you may have the pleasure of passing the lava from one to another. Receiving and giving the lava according to rule means a successful year, but woe to the one who drops it, for to him will come disappointment."

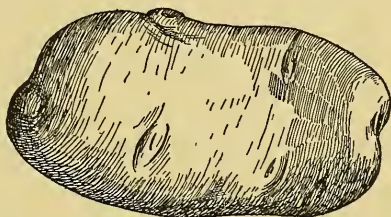

Fig. 58.—The lava from Mt. Pelee.

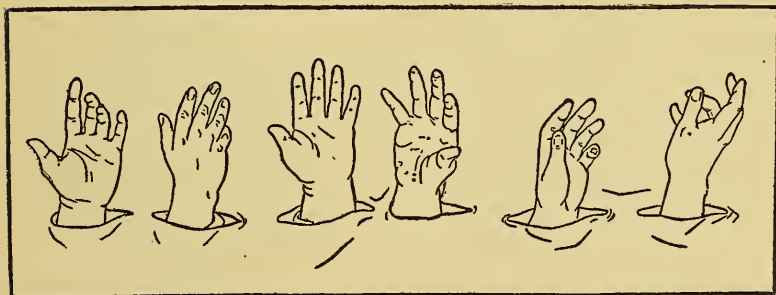

Fig. 59.—Slip your hands through openings in the witch screen.

After you have made your little speech, sit down and, hidden by the screen, take from a tray at your side a hot potato (Fig. 58), which has been in the oven only long enough to become thoroughly heated; place it in the hand at the head of the line with the words, "I give you the charmed lava; pass it on." Though the girls and boys may not see what they have, they can assuredly feel it, and there comes in the fun, for each in turn will be sorely tempted to drop the hot potato and yet not dare to do so, and

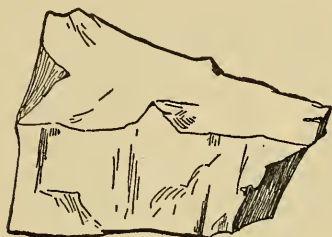

Fig. 60.—The wonderful Japanese crystal.

no hint being given, the next neighbor will in turn be equally startled. When the lava reaches the last player, some one back of the screen at that end must receive the precious object and store it away on a tray.

As soon as the hot lava is disposed of, arise and tell the company that the next charm is a piece of

### Wonderful Japanese Crystal

(Fig. 60). It will enable them to see and understand everything more quickly and clearly; it will also gain new friends and delightful surprises. To drop the crystal brings dulness of comprehension, no friends and no surprises. Use a piece of ice for this. The third charm is a rare natural history specimen, called

### The Baby Porcupine

(Fig. 61). The little creature signifies difficulties successfully over-

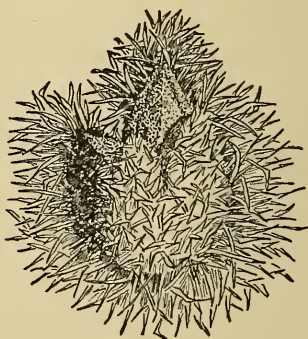

Fig. 61.—The baby porcupine.

come, but if dropped the fortune will be reversed. The porcupine is in reality a chestnut bur.

### **A Harmless Serpent**

forms the fourth charm; it renders all girls and boys proof against fear of wild animals, and imparts the faculty of taming and making pets of many inhabitants of the forest, but the charm will be lost with one failing to pass it on its way. The serpent is a snake made of soft dough.

One of the best fairy gifts is

### **A Treasure from the Great Blue Sea**

It means a joyous ocean voyage to new and beautiful lands, but if dropped, the player will encounter storms and perils. Hand the first player a slippery raw oyster.

When all the charms have been tested, announce that before returning the treasures to the witches you will place them on exhibition; then turn back the witch screen and let the girls and boys gather around the tray of queer charms, where they can laugh and exchange comments to their hearts' content. The effect of the witch screen may be enhanced by using a breadth of brilliant-red muslin and pasting on it black moons, stars, cats, etc. Erect at each end of the screen a comic pumpkin lantern head, with white paper fastened on the inside over the features to light them up, instead of a real light placed inside. Slide each pumpkin head on the end of a pole, and rest the pumpkin firmly on four long, strong nails driven in around near the top of the pole. The lower end of each pole may be steadied and supported by being inserted in a hole bored through the centre of a heavy piece of plank, where it must form a very tight fit; or you can sink the pole into a deep pail of stones and earth.

If it is possible to have the only light in the room placed back of the screen, the effect produced will add to the mystery and enchantment. Make all decorations as funny as you like, but avoid anything grotesquely unpleasant. Let every item be agreeable, from the least to the most important arrangement for the evening's fun.

A very pretty way of telling fortunes is with

### Fairy Airships

made of feathers. Take as many fluffy feathers as there are girls and boys in the party and paste on each feather a prophecy written on a bit of paper, such as:

Yes,	I'll try,
No,	When the time comes,
Sometime,	Of course,
Possibly,	Three times,
Never,	Before you know it,
At twenty-five,	Not if I can help it,
Probably,	Certainly,
Depends on myself,	Doubtful,
If I can,	Surely.

Put all the fairy airships into a pasteboard box-lid, which you have previously punched full of holes, and, standing on a stool or chair, hold the box-lid high in the air while you slowly and impressively say to the company: "These fairy airships will decide your fate regarding marriage. Will you marry?" At the word "marry" launch the ships of fate by fanning vigorously under the box-lid with a large palm-leaf fan, which will send the ships flying in every direction; as they sail through the air each player must endeavor to catch one before it falls.

When order has been restored and all have their airships, each

girl and boy in turn must read aloud the prophecy brought by the fairy vessel.

All the party will enjoy the

### **Blarney Stone Game**

Place a large, clean stone on a doily-covered fancy plate which rests on a table in the centre of the room, and tell your guests that a certain spell cast on the famous Blarney Stone in Ireland caused the virtues of that wonderful stone to be transmitted to the stone in the very room where they stand, and that if a girl or boy, when blindfolded, can walk up to the table and kiss the Hallowe'en Blarney Stone, she or he will ever after be jolly and happy and prove a most agreeable companion. Then tie a handkerchief across the eyes of each of the players in turn and let them walk up to and try to kiss the stone before the witches come to take away the magic spell, which they will do long before the clock strikes twelve at midnight.

During the evening be sure to try fortunes by the

### **Fortune Jingle**

On different sheets of paper write one of the following verses:

“One is good fortune,  
Two a light heart,  
Three is a carriage,  
Four is a cart,  
Five is a new dress,  
Six, a new hat,  
Seven is a pet dog,  
Eight, a pet cat,  
Nine is a letter,  
Ten is a pleasure,  
Eleven is a great joy,  
Twelve is a treasure.”

Place each verse in a separate envelope and hang all on a string stretched and tied to the backs of two chairs. Distribute squares of paper each marked with a number beginning at number one. The player receiving number one has first choice of envelopes from the line. Two brings second choice, and so on. When all missives have been taken and the signal given for opening the envelopes, the player receiving verse one reads aloud, "One is good fortune"; immediately after the person with number two reads, and the other verses follow in numerical succession, every envelope bringing its gift to the recipient.







Titania Stands on Her Toes, She Floats, She Drops to the Floor in a Deep Curtsy.

## CHAPTER VI

### DANCE OF TITANIA, QUEEN OF THE FAIRIES



TITANIA is a graceful little fairy, dancing as though she had learned the art from the bending of the grass in a summer breeze, the swaying of the trees or the flitting of butterflies from flower to flower. Light, airy, with gossamer wings and filmy dress, looking as though she needed nothing more substantial than silvery moonbeams to dance upon, the little queen leaves her home in the

deep, wild woods and comes to do your bidding.

#### Have Titania's Stage Ready

that she may not be kept waiting, for queens and fairies will brook no delay (Fig. 62). Find a wooden box  $18\frac{1}{2}$  inches long by 13 inches wide or larger (Fig. 63). With a heavy hammer or a hatchet pry up and knock off the top and one of the long sides (Fig. 64). The open side forms the front of the roofless stage.

The coloring of the stage should be a light sage green. If possible, procure this color in cartridge wallpaper wider than the stage. With a string measure the distance across the back

wall of stage from top to bottom (A to B Fig. 64), continue the measurement in the same straight line across the floor of the stage from back B to front C. After allowing five extra inches

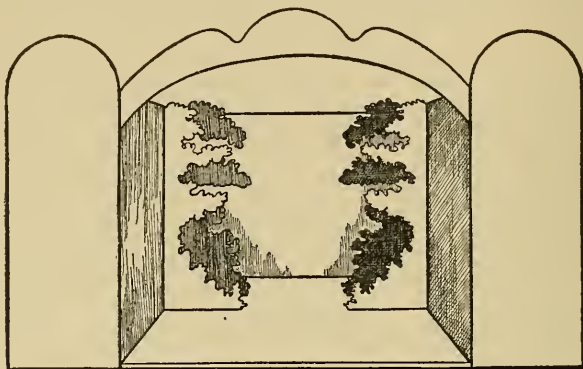

Fig. 62.—Titania's stage.

for turning the paper over the top edge of the back wall A and front edge of floor C, cut the length according to measurement.

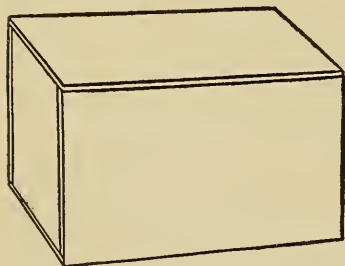

Fig. 63.—The wooden box for Titania's stage.

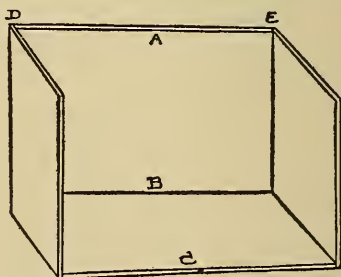

Fig. 64.—Knock off the top and one of the long sides.

To make the strip of green paper the required width measure the exact distance across the inside back wall from side wall D to side wall E, then fold the paper evenly along each lengthwise

edge, making it the width needed; unfold and adjust the paper against the back wall over its top edge and over the floor of the stage. Cut short slits on each side of the paper where the floor and wall meet, that the extra width may lie flat up against the side walls. Bend the top edge of the paper over the top of the back wall, again slashing a little on each side to make it fit top edge of wall. In the same way bend the paper over the front edge of the floor; see that the paper lies perfectly smooth, then fasten it in place with small tacks, using three tacks on the outside at the back, one at each corner and one in the middle; two tacks where floor and wall meet, and three underneath front of floor. Measure the side walls, cut paper to fit and fasten the paper on the walls with as few tacks as possible.

When the inside papering is finished, cover the outside of the stage with pretty cretonne. Make four inside wings, two for each



Fig. 65.—Back wing for stage.



Fig. 66.—Forward wing for stage.

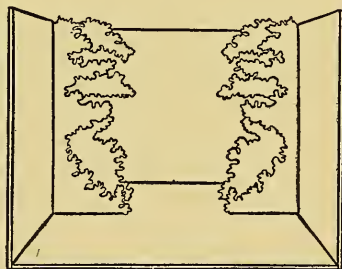

Fig. 67.—Fasten the wings to the side wall of the stage like this.

side of the stage, to represent the foliage of trees. Cut two like Fig. 65, from paper of a darker green than the walls of the stage and reverse one of them that they may face each other. Then make two wings, like Fig. 66, from paper of a lighter green than the walls, and reverse one of these also. The walls of the stage

with the two sets of wings will make three different tones of green forming the background. Cut the wings long enough to extend up as high or higher than the side walls of the stage. Bend each strip lengthwise at dotted line and paste the bent margin of one wing from Fig. 65 on each side wall, running the wing up from the floor to the top of the wall about four inches from the back wall. In the same manner fasten the wings (Fig. 66) on each side wall three inches in front of the first or back wing (Fig. 67).

Cut the arch (Fig. 68) of stiff pasteboard. The cover of a pasteboard box will do. Make the arch long enough to span the space across the front of the stage and let the lower edge of the curve in the centre of the arch be five and a half inches higher than its two ends (see dotted line, Fig. 68).



Fig. 68.—The arch.

with green paper, gluing it on only along the edges. Tack the ends of the arch to the top of the two side walls (Fig. 69).

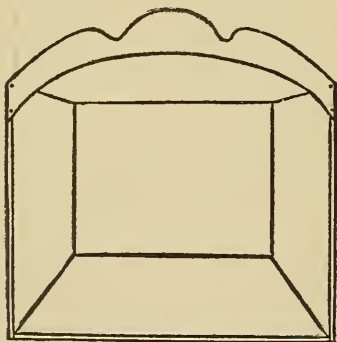

Fig. 69.—Tack the ends of the arch at the top of the two side walls.

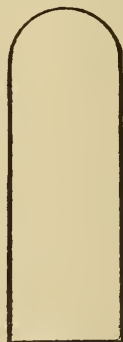

Fig. 70.—Pasteboard extension for front of stage.

Cut two pieces of pasteboard like Fig. 70, making each six inches wide and almost as high from floor of stage as is the top of the centre of the arch. Paper these also with green, both front and back. Tack one piece of the pasteboard on the front edge

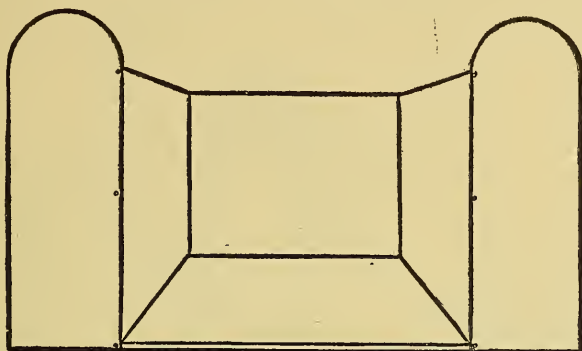

Fig. 71.—Tack one piece of pasteboard on the front edge of each side wall of the stage.

of each side wall of the stage, allowing it to extend out from and beyond the side wall (Fig. 71). Bore a hole with a gimlet through the centre of the back wall of the stage five inches up from the inside floor, and your stage will be finished.

### Make Titania

(Fig. 72) of light-weight cardboard. When finished she should be ten inches in height from her toes to the top of her head. Fig. 73 is the diagram of the body and arms, measuring three and five-eighths inches from top of head to lower edge of body. Cut the two upper portions of the legs (length two and one-half inches, greatest width one inch) from Fig. 74, and the two lower portions (length three and three-eighths inches) from Fig. 75. Join the two parts of each leg together, according to the

dots, with a strong thread and needle, and fasten with a knot on front and back, so that the two pieces will be strung upon the



Fig. 72.—Titania.

same thread and sandwiched between two knots of the thread. Attach the legs to the body in the same manner. The small



circles A, A on the doll's body (Fig. 73) give the exact spots where the thread should pass through, and the curved line above each letter shows where the upper edge of the top part of the leg should reach. Dot B marks the point on the upper part of the leg (Fig. 74) where the thread goes through, joining the leg to

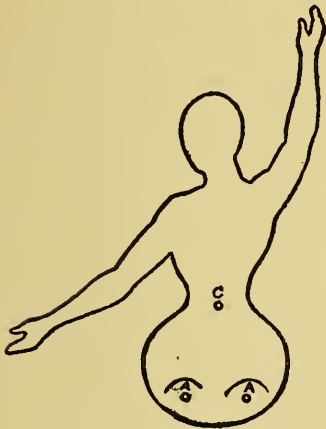

Fig. 73.—Cut the body and arms of Titania like this.

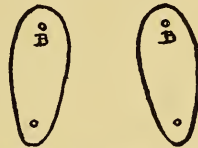

Fig. 74.—Two upper portions of legs.

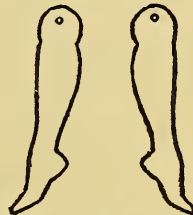

Fig. 75.—Lower part of legs.

the body. Have all the joints of the doll securely fastened and only loose enough to move easily.

Find a pretty head in some old paper or advertisement, cut it out and gum it on the pasteboard head. Remember, though, that the printed head must not be of very heavy paper, as the upper part of the doll should be lighter in weight than the lower, otherwise the figure will not balance. If you cannot find a head in colors, you must paint the printed black-and-white one; give the face, neck and arms a flat wash of light-pink water-color paint; color the lips and cheeks red, the eyes blue and the hair

brown. Make the long stockings a darker pink than the light flesh tones, and paste slippers of gilt paper on the feet.

Puncture a hole with a coarse needle through the centre of the belt-line (C. Fig. 76). For

### **Titania's Costume**

make a skirt of plain white tissue paper. Cut it sixteen inches wide and three and a half inches long, after creasing the skirt by gathering up the fulness with your fingers and drawing the skirt lengthwise from top to bottom through your partially closed hand. Gather the top of the skirt with thread and needle, and fasten it on the doll, then slit up each side from the lower edge to allow of the free motion of the doll's limbs.

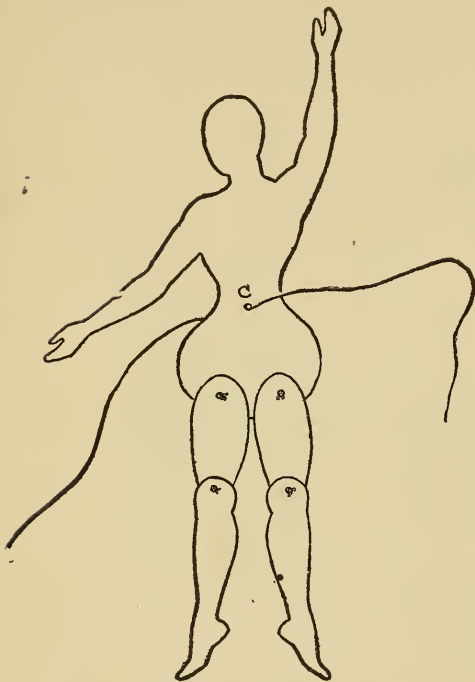

Fig. 76.—String the doll together in this way.

Make the dress of pink chiffon. Cut the dress skirt three and three-fourth inches long and one yard wide, press it in knife-blade plaits, running up and down, then gather and tie it on the doll over the white tissue-paper skirt. Do not attempt to hem any portion of the clothing, as the object is to keep it all light and airy. Fashion the waist of a smooth strip of pink chiffon tied with narrow pink ribbons at the shoulders and brought down to the

belt-line into a point back and front, and sewed in place. Form a silver girdle of the tinsel ruching used on Christmas trees; place the tinsel around the Queen's waist, allowing the two free ends to hang down over the front of the dress. Glue a little of the same tinsel around the front of her dark hair, where it will shine like a crown of diamonds. Make Titania daintily hold up and out each side of her dress. Do this by stretching out the sides of the dress skirt and gumming the material to each wrist.

Cut a scarf of pink chiffon four inches wide and sixteen inches long, fasten one end in each hand of the fairy Queen and let the scarf fall in a graceful loop.

### Queen Titania's Wings

must be of the pink chiffon cut shawl shape, two sides straight and one bias (Fig. 77). Plait the bias edge (Fig. 78) and gum the wings in place on the Queen's shoulders at the back.

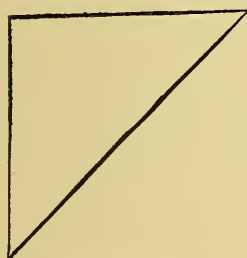

Fig. 77.—Cut the wings shawl shape.

Take a needle threaded with black thread, two or three yards long; run the needle through the centre of the belt-line of the dressed fairy at the point C (Fig. 76); then thread it



Fig. 78.—Plait the bias edge.

through the gimlet hole at the back of the stage and tie a button on the end of the thread which extends outside of the back wall. Pull the thread on the inside of the stage until the button lies tight up against the outside of the back wall. Allow sufficient length of thread to bring the Queen within about three inches of the front edge of the stage, then make a knot in the thread immedi-

ately back of and another in front of the Queen to prevent her from slipping either forward or backward. Tie the long, loose end of the thread on a small empty spool, that it may be wound up and kept from tangling when not in use.

#### **Place the Stage on a Chair**

facing the light and, carrying the thread in your hand, take your station two yards or more away from and in front of the stage; then practise moving Titania by means of the thread until you can make her glide, pose and dance in many graceful attitudes. She will lean to the right and to the left, will stand on her toes, then curtsy, making her dress touch the floor; she will move gently and slowly, again faster and faster until her feet seem to fairly twinkle over the stage floor; she will pass back and forth almost as if floating from side to side of the stage, or stand in the centre and dance. Titania is ever fascinating, beautiful and graceful in all her movements. Ask some one to play on the piano while you make the fairy Queen dance and she will keep time to the music. When you have learned to make Titania dance her prettiest invite your friends in to see the little fairy.

## CHAPTER VII

### THANKSGIVING PARTY

#### Apple, Orange and Pumpkin Games



WE must have six little yellow pumpkins for our new Thanksgiving game, but we may hunt high and low, far and near, for real ones the required size, and not find them, because natural pumpkins are much too large.

So we shall have to make oranges and apples into

#### Little Pumpkins

Select apples about two inches in diameter, all as near of a size as possible and preferably somewhat flattened at top and bottom. Cut a square of orange-colored tissue paper and stand an apple, stem upmost, on its centre (Fig. 79). Bring one side of the tissue paper up

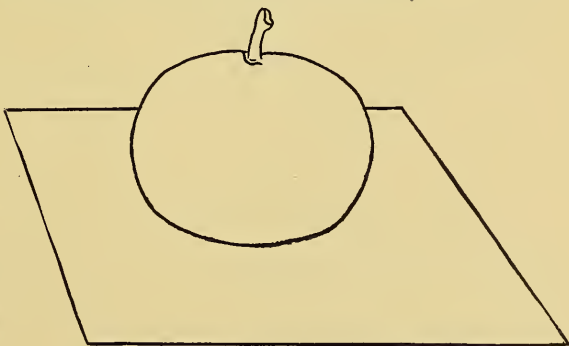

Fig. 79.—Stand an apple on a square of paper.

to the top of the apple and take a wee plait in the paper, at the same time smoothing it up from the bottom of the apple (Fig. 80). Make several more plaits and bring the nearest corner of

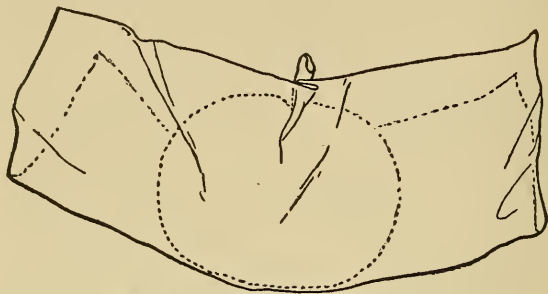

Fig. 80.—Take a plait in the paper.

the paper up to the apple top. Continue plaiting the tissue paper around the apple (Fig. 81) while constantly smoothing it up from the bottom and over the apple until the apple is completely covered and all the edges and corners of the orange-colored



Fig. 81.—Bring the nearest corner of the paper to the top of apple.

paper are folded and brought together at the top of the apple (Fig. 82). Hold the covered apple in your left hand and with your right hand twist the ends of the tissue paper around the stem (Fig. 83).

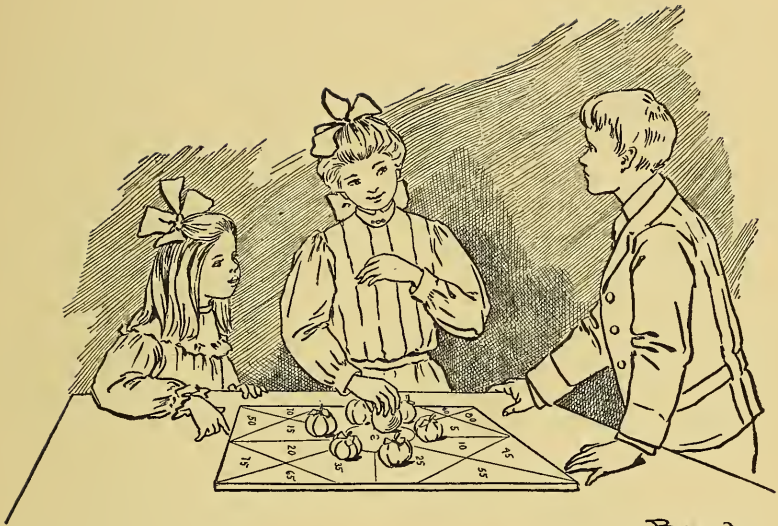

Playing the Pumpkin Game.





Examine the apple and make sure there are no raised ridges in the paper and that the entire covering lies flat and smooth. Tie one end of a piece of brown thread around the base of the



Fig. 82.—Constantly smooth it up from the bottom until the apple is covered.



Fig. 83.—Twist the ends of the paper around the stem.

stem. Wind the long end of the thread once tightly around the apple, giving it a twist around the stem to secure it in place (Fig. 84). The thread must pass across the exact centre of the blossom



Fig. 84.—Wind the long end of the thread tightly around the apple.



Fig. 85.—Pinch a square of green tissue paper over the stem.

end of the apple. As you wind the thread turn the fruit and watch the thread that it may not swerve either to this side or that. A second time wind the thread around the apple, making

the first encircling thread band double. Cross this double band with another double band, marking the apple into quarters, se-



Fig. 86.—Tie a thread around the base of the stem.

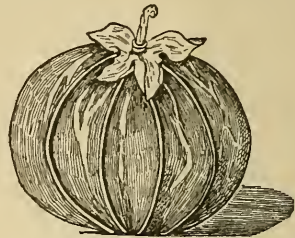

Fig. 87.—A little yellow pumpkin.

cure the thread about the stem, and again wind it around the apple, dividing two opposite quarters each into two pieces.

Divide all the quarters in the same way, then pinch a small square of bright green tissue paper over the covered stem (Fig. 85), smooth it down close and tight and tie a thread around the base (Fig. 86). Bend the extreme end of the stem until it curls, and the result will be a cunning little yellow pumpkin (Fig. 87). Fig. 88 shows how the cross threads should meet at the centre of the blossom end of the fruit.

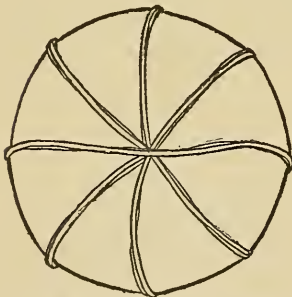

Fig. 88.—Shows how the cross threads should meet.

An ordinary pastry-board about twenty-six inches long and nineteen inches wide must do duty for

### The Game Court

(Fig. 89). Find the centre of the board by running two straight lines diagonally across from corner to corner, the spot where the

two lines meet and cross marks the centre of the board (Fig. 90). Make a small circle two inches in diameter around centre spot, surround this circle with a larger circle seven inches in diameter. Erase the diagonal lines within the circles and run straight lines

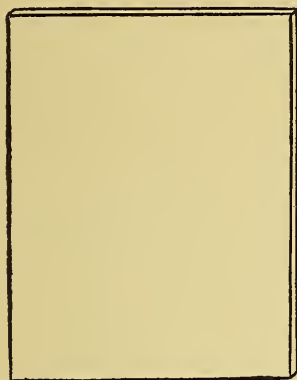

Fig. 89.—A pastry-board for the Game Court.

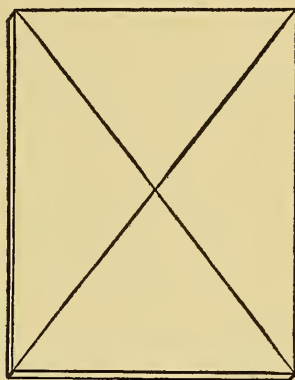

Fig. 90.—Run two straight lines from corner to corner.

radiating outward midway between the diagonal lines from the edge of the larger circle across the face of the pastry-board. With four more lines cut off the four corners of the court, number the divisions as in Fig. 91, and the game court will be finished.

Stand the little pumpkins, at equal distances apart, on the larger circle of the court, and on the small circle stand a natural, large, round apple without tissue paper cover.

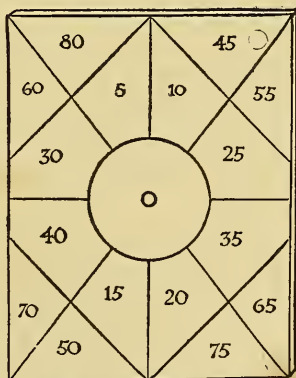

Fig. 91.—The Game Court is finished.

### The Game

may be played by any number. The object of the game is to spin the apple so that it will hit one or more of the surrounding pumpkins and roll or shove them on to the highest marked divisions of the game-court.

Each player is allowed only one trial at a time, turns being taken successively by the different players. The spinning of the apple must always be started on the small central circle where the apple is stationed. When the apple rolls off the board the player may have another trial; if the apple rolls off on the second trial she simply loses her turn, there being no other penalty. When a pumpkin lands on one of the dividing lines it counts ten against the player. Often an apple will strike several pumpkins, sending them off on different divisions. Every pumpkin then counts the number in the division on which it stops; sometimes more than one pumpkin will land in the same division, and each pumpkin so landing counts the number in that division. When the apple sends but one pumpkin, the player scores merely the number of that one division on which it lands. After each play the pumpkins must be replaced in the circle ready for the next player.

Five rounds constitute a game and the highest record scored wins. When played by sides there must be an equal number of players on each side. The side making the highest score wins the game.

For the next game let all the players sit on the floor in a ring and by the light of only wee pumpkin lanterns tell a

### Rapid-Transit Thanksgiving Story

The leader must begin the tale, which may or may not be original. He must speak for only a few minutes, then stop, when his right

hand neighbor, without hesitation, must take up the story and carry it on for a few moments. In this way the story goes the round, each right-hand player in turn telling his part. Every player has the privilege of making his portion of the tale original, even though the preceding part may not be so. It is also the privilege of every one to change the story to a dream, or a fairy tale. Quotations may be introduced, verses recited, or snatches of song sung; in fact, the oftener the story is twisted and turned the greater the interest; but there must always be some connection between the part being told and that which has gone before. The entire romance must be finished before the light in the wee pumpkins burns out. If a player should fail to continue the story when his turn comes, he must pay a forfeit, and when the story is finished, redeeming the forfeits adds to the fun.

If many guests are present, divide them into small groups for the rapid-transit story.

Make a miniature

### **Pumpkin Lantern**

for each girl and boy present. Take a symmetrical apple which stands firm and steady on the blossom end. Select the best side for the face, and with the small blade of a penknife cut on it a crescent with ends turned upward for the mouth. Cut a triangle for the nose, two small squares for eyes, and two short crescents, points turned upward, for eyebrows (Fig. 92).

Turn the apple over and cut an opening in the back as shown at Fig. 93. Be extremely cautious not to break or tear the edges of the apple skin while cutting the features and back opening. With the small blade of the penknife inserted at the back opening cut away the inside of the apple little by little, taking great care not to drive the knife far enough into the apple to puncture the skin.

When you reach the core, screw the large blade of the knife around until the core is sufficiently broken to allow of being cut



Fig. 92.—Cut features in the miniature pumpkin.

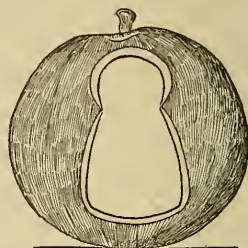

Fig. 93.—Cut an opening at the back.

away without danger of injuring the apple skin by accidental stabs.

After most of the inside has been removed turn the apple around and look at the features; if you cannot yet see daylight through them, insert the small blade from the outside of the apple, through each feature in turn, and by degrees cut away the meat, without enlarging the openings of the different features. Should this prove ineffectual, again turn to the back of the apple and work from the inside, removing more of the contents and making the layer of apple thinner next to the skin. Then once more try through the features from the outside. This time the result should be distinctly clear openings for all the features. You cannot help smiling when you look at the apple now, for you see such a comical little face.



Fig. 94.—Cut a section from a candle.



Cut a short section from an ordinary wax candle (Fig. 94), shave down the sides, mak-

Fig. 95.—Make the bottom larger than the top.

ing the bottom heavier and larger than the top (Fig. 95). Run a pin through the centre of the candle from bottom to top; then pull it out. Fit the candle inside on the centre of the bottom of the apple, hold it in place while you run the pin up from the outside of the apple, through the skin and into the pinhole in the centre of the little candle. The pin should hold the candle firmly in place; if it does not do so, pull the pin out and see what is the matter; possibly the candle needs hollowing out a trifle



Fig. 96.

Orange Lanterns.

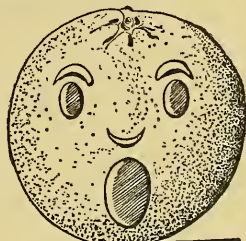

Fig. 97.

at the base in order to fit the slight rise in the apple on which the candle stands. Put on your thinking cap, examine and *make* the candle stand absolutely straight and firm.

Manufacture all the other individual pumpkin lanterns in the same way, and when story-telling time arrives set a lantern in front of every girl and boy in the circle and light the candle in each little pumpkin. The effect will be charming and inspiring for the story-tellers. Oranges with all the pulp extracted also makes very pumpkin-like lanterns when cut in a similar way to the apple lanterns (Figs. 96 and 97).

Anything may be given as

### A Forfeit

and the forfeits are redeemed in the good old way. The leader is blindfolded and seated. A girl or boy stands back of the

leader, and, taking one of the forfeits, holds it over her head, while repeating these words, "Heavy, heavy hangs over your head." The leader replies with the question: "Fine or superfine?" If the forfeit belongs to a girl, the answer is "superfine," if to a boy, "fine." The same player adds, "What shall the owner do to redeem it?" The leader names a penalty, such as, kneel to the prettiest, bow to the wittiest, or, look angry, then smile your sweetest. The leader may inflict one of these, or any other, making the penalty as funny as she desires, but it must never cause a player to feel in the least uncomfortable, for every girl and boy should be given just as good a time as possible, that all may return to their homes from the Thanksgiving games happy and pleased with their evening's fun.



## CHAPTER VIII

### IMPROMPTU MOVING PICTURES FOR THANKSGIVING



HIS entertainment is one that girls can get up themselves, though of course boys may take part. It is very funny if well carried out and will give every one a hearty laugh, which we all know is a good thing after the Thanksgiving dinner.

First make the poster, to be hung in a conspicuous place in hall or parlor.

Print it in large black letters on a good-sized sheet of wrapping paper:

**There Will be To-night  
An Exhibition of  
The World-Renowned  
Moving Pictures**

**Taken by Madam Moselle at Great Risk of Life and Property.**

**No Expense or Effort Being Spared to Obtain the**

**Real Characters and Settings**

**of a**

**Puritan Thanksgiving**

**And Other Scenes from the Life**

**of Our Forefathers.**

Make the picture screen by stretching a large white sheet on the back wall of the room where the performance is to be held, as you would for a magic lantern exhibition. Then get your costumes ready. These may be made up very quickly from materials at hand.

### The Puritan Woman's Dress

as well as that of the man must be entirely of black and white, and to carry out the effect of black and white pictures their faces and hands should be made perfectly white with chalk, their eyebrows blackened and black wigs made of fringed tissue paper. Only a little of the woman's hair will show but the man's should be long and hang down to his shoulders. A tight black waist and skirt nearly to her ankles; a long white apron, white kerchief and cuffs (cut from old muslin) and a tightly fitting little black cap with a turned over edge of white form the costume of the woman. With these should be worn low black shoes and white stockings. For the

### Puritan Man's Costume

have short, full, black trousers, long black or white coat with wide white collar and cuffs, a high-crowned, broad-brimmed



Fig. 98.—This is the way to cut the Puritan's collar.



Fig. 99.—Cut the wide cuff like this.

black hat and low shoes with black stockings. A black leather trunk strap buckled across one shoulder may be added, also a long black cloak and staff. Cut the man's collar and cuffs like



Puritan Costumes for the Moving Pictures.

L. O. C.



Figs. 98 and 99, and the woman's cuffs like Fig. 99. Fig. 100 shows how the Puritan hat is made of stiff brown paper over an

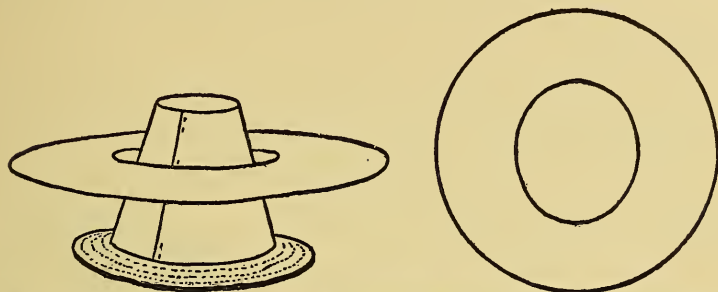

Fig. 100.—Put the Puritan's hat together in this way. Fig. 101.—This is the hat brim.

ordinary straw hat. Fig. 101 is the brim, Fig. 102 the crown, which must be pinned together along its straight edges.

### The Properties

for the Thanksgiving dinner scene are a long, narrow table spread for dinners, and chairs enough for the actors, six or eight taking part.

Before showing her pictures Madam Moselle should stand in front of the screen and say a few words extolling the pictures she is about to present.



Fig. 102.—This is the crown of the Puritan's hat.

The girl who represents Madam Moselle should deliver an amusing little speech, giving a foreigner's idea of our first Thanksgiving, and it can be made absurdly funny with its many ludicrous mistakes.

At the close of her address the lights must be put out and the scene quickly arranged close to the screen, all the actors except two being seated at the table. Thus remain two empty chairs.

As quickly as possible the light should be turned on and at the same time the actors must begin

### A Pantomime

of eating, drinking and talking.

They should express anxiety for the safety of the tardy guests, some of them leaving the table to appear to look out of a door or window.

All the while (this is the great point) the actors must shake and quiver in imitation of the queer trembling and quivering always seen in the moving pictures; and their movements must be very rapid.

Soon the missing couple should appear, coming in hurriedly and by gestures telling of an encounter with the Indians.

Their clothes should be pierced with arrows, and the Puritan's hat must be bristling with them.

All this will be very laughable if the acting is good, and absurd little by-plays introduced; but the whole thing will be spoiled unless the constant quivering and shaking is kept up by all of the actors.

The picture can be "flashed off" the screen by simply turning out the light, and others may be shown giving various incidents in Puritan life or the early history of our country.

## CHAPTER IX

### A VALENTINE ENTERTAINMENT WITH ORIGINAL VALENTINES

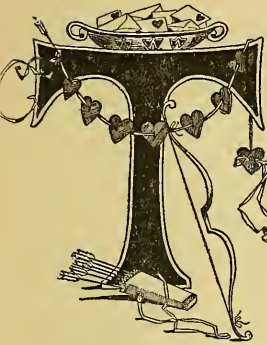

THE fun of the Valentine party begins with the invitations, which are in the shape of a heart. The message on the outside (Fig. 103) leads to the opening of the invitation (Fig. 104), and on the inside are found the time and place where the frolic is to take place and the names of those who are to give the party.

To make the design, fold through the centre a square piece of paper measuring five and one-half inches along each edge. Fold this oblong crosswise through its centre, and you will make a small square of four layers of paper. On one side

of this square mark the outline of a heart, allowing the corner of the small four-folded square, which is also

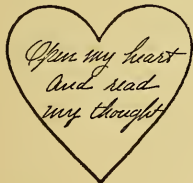

Fig. 103.—The invitation closed.



Fig. 104.—Invitation opened.



Fig. 105.—Cut out the top of the heart through all four layers.

the centre of the large square of paper before it is folded, to form the point of the heart (Fig. 105). Cut out the top of the heart through all four layers of paper, also the curves of the sides of the heart; cut these only part way down as shown by A and A (Fig. 105). The dotted lines in Fig. 104 represent creases.

Answers to the invitations might read:

“My dear Miss Darling and Miss Love, too,  
 I’ve opened your heart and will come to you  
 On the day you’ve appointed, the pleasure is mine,  
 And I hope you’ll accept me as your Valentine.”

Make as many valentines as there are guests, that all may be sure of receiving at least one. Address each of the girls’ valentines “To My Sweetheart,” and each of the boys’ valentines, “To My Valentine.”

Let either a girl or a boy be selected to run

### The Post-Office

which you can make of a clothes-horse draped with sheets. Place a table inside across the opening, and on the table, resting on a pile of large books, stand an empty wooden box minus top and bottom. Set it up on one end to serve as the post-office window. The table and space on each side of the window should be screened with sheets. Across the outside top of the window fasten a pasteboard sign marked in large letters:

### ST. VALENTINE’S POST-OFFICE

and decorate the white sheets covering the clothes-horse with red paper hearts of various sizes fastened on singly, doubly and in festoons. On the table at the right-hand side of the window



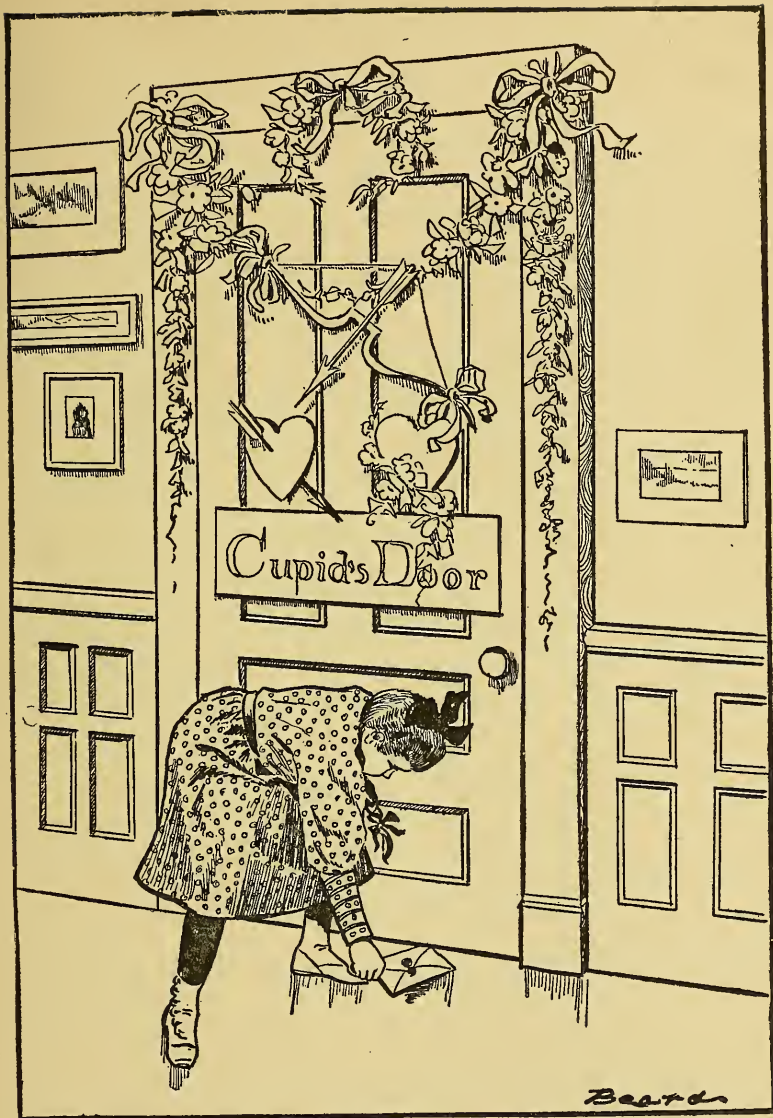

*Beards*

Sending Her Valentine.



place the girls' valentines and on the left-hand side of the window the boys' valentines.

Ask all the girls to form in line and march around the room to the post-office, while some one plays a suitable lively air on the piano. Each girl in turn must stop at the post-office window, where a box of St. Valentine's stamps is set before her with one of the boys' valentines. She must close her eyes and take one stamp from the box, then open her eyes, read the stamp and on it sign her name at the right-hand corner, then fasten the stamp on the valentine with paste given her by the postmaster, and move onward to give place to the next girl in line.

When all the boys' valentines have been stamped, the girls take their seats and the boys form in line and stamp the girls' valentines in the same manner.

### **The Valentine Stamps**

should be previously prepared. They are made uniform in size of small squares of white writing paper, on which is written any kind of a wish which may add to the fun, such as:

I wish you would smile at me.

I wish you would sing me a song.

I wish you would tell me a funny story.

I wish you would sit by my side now.

I wish you would walk around the room with me.

I wish you would recite poetry to me.

When entering the room each guest is given a card. On one card is written,

### **"When the Bell Rings**

once go to the post-office"; on another, "When the bell rings twice go to the post-office," and so on, each card designating a

specified number of rings. The postmaster sounds the bell at intervals, giving a different number of taps at each ring, until every girl and boy is supplied with a valentine; then each boy seeks the girl who has signed the stamp on his valentine and she asks that the wish be fulfilled. The request is, of course, laughingly and courteously granted. The valentines being sealed with St. Valentine's stamps, the mystery of the sentiment enclosed cannot be revealed until the wish on the stamp is granted, and neither the girls nor the boys are aware of the contents of the valentines they stamp. Later in the evening the girls find the boys who have signed their stamps, and then, entering into the spirit of the fun, they grant the boys' wishes as written on their stamps.

The guests may bring extra valentines made especially for and directed to either hostess or guests. These are not sent through St. Valentine's post-office. The hostess keeps one door of the parlor closed for the benefit of those desiring to send special valentines. A sign posted upon it reads:

### CUPID'S DOOR

and quantities of paper flowers with gilded pasteboard hearts, bows and arrows adorn it, giving it a very festive appearance. Each guest is at liberty at any time during the evening to slip from the company, make her way through the hall to Cupid's door, slide her valentine under the door, give a quick knock and scamper off before she is caught. Only the hostess has the privilege of opening Cupid's door, and to her belongs the pleasure of delivering these valentines to the various guests for whom they are intended.

There are many styles of valentines which you can make.

Fig. 106 is effective and requires only a few moments to manufacture. For

### The Heart Valentine

use a plain white card about four and one-half inches long and three and one-half inches wide for the foundation. Make four hearts graduated in size, the largest of red paper, the next gold, then green, and the smallest of blue paper. Cut a small slit in each heart a short distance from the top centre (Fig. 106). String the hearts on a narrow ribbon and tie one end of the ribbon through two slits cut in the lower left-hand corner of the card, and run the other end of the ribbon through two slits in the upper right-hand corner, then tie. Write across the top of the card, "Make your choice."

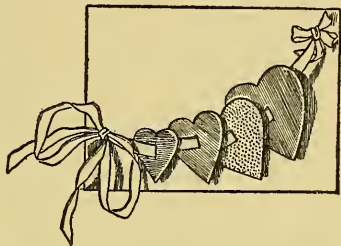

Fig. 106.—Which heart will you take?

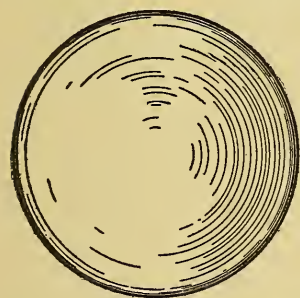

Fig. 107.—Shade a little to suggest roundness.

Beneath it write this verse:

"The Red Hearts take without return,  
The Green with envy always burn,  
The Blue are cold and hard and small,  
The Gold ask nothing but give all."

### The World Valentine

is another design. For this use a circular piece of white paper about four inches in diameter. Shade it around the edge a little to give an idea of roundness (Fig. 107), then with ink draw on the disk the outlines of North and South America to represent the world (Fig. 108). Paint the continent a light yellow. Put the lettering

on in bright colors, placing an awl drawn in outline (Fig. 109) and a figure 2 in the position shown in Fig. 110. Paint the awl red.



Fig. 108.—North and South America.



Fig. 109.—The awl.



Fig. 110.—You are all the world to your valentine.

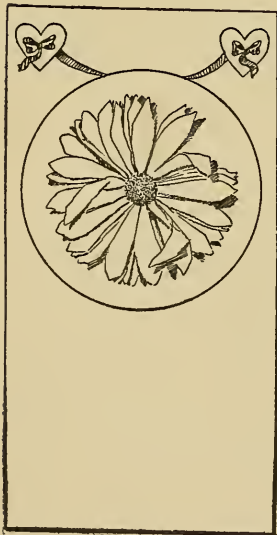

Fig. 111.—The daisy valentine.

This message is a rebus and reads: "You are all the world to your Valentine."

### Next Comes the Daisy Valentine

(Fig. 111). On a piece of paper six inches long and three and a half inches wide draw a circle near the top, making it not quite three inches in diameter. Paint the circle bright green as a background for the white daisy. Make the daisy of three or four layers of white tissue paper folded like Fig. 112 and cut along the scalloped outline shown in Fig. 112. Unfold the petals and they will be like Fig. 113; but as the number should be odd, you

must cut off one of the petals. Sew the centre of the daisy to the centre of the green circle, then paste a small yellow paper disk (Fig. 114) over the stitches. Paint a small red heart at each upper corner of the valentine



Fig. 112.—Paper folded ready for making daisy.

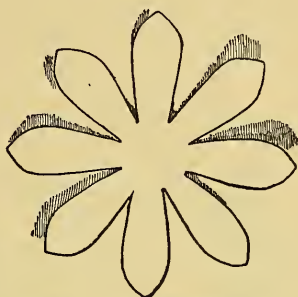

Fig. 113.—Petals of daisy.

and paint a narrow blue ribbon tied to each heart and looped between, as in Fig. 111. If the valentine is intended for a girl write under the green circle in red letters:



Fig. 114.—Yellow center for daisy.

“Pluck the daisy petals off, saying first: ‘He loves me.’  
With the next: ‘He loves me not.’  
Then again: ‘He loves me.’  
With the fourth: ‘He loves me not.’  
Going on: ‘He loves me,’  
Till the last when torn away  
Tells you this: ‘He loves you.’”

When the valentine is for a boy substitute the pronoun She in place of He.

### Love's Palette,

the last valentine (Fig. 115), is to be made of light cardboard cut in the shape of a palette. The palette should be about six inches high and four and one-half inches wide at the broadest part. Beginning near the top, cut short slits in pairs in the palette, placing the pairs one inch and a half apart (Fig. 116).

Get a quarter of a yard each of narrow blue, red, white, yellow, pink and green ribbon, and slipping the ends through the slits



Fig. 115.—Love's palette.

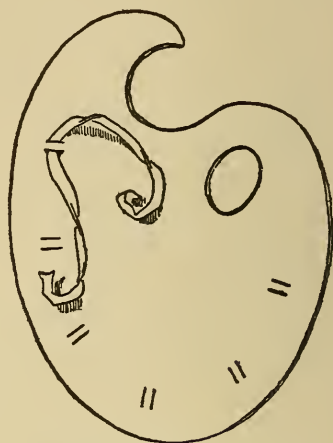

Fig. 116.—Slits cut in palette.

in the palette tie them in bows as shown in Fig. 115. In the centre write in red ink, "Love's Palette," and on the back the following lines:

"This ribbon blue means I am true.  
 The knot of red says, 'Will you wed?'  
 The bow of white, 'You're pure as light.'  
 The yellow, too, means thoughts of you.  
 The tie of pink is love's own link.  
 The loops of green say, 'Youth so keen  
 Must conquer all and win his queen.'"



## CHAPTER X

### THE WILD WEST SHOW ON A TABLE



ITY people, country people, young people, old people, busy people, idle people, all come flocking to the Wild West Show when it posts its gay pictures and spreads its fascinating white tents for the benefit of the public.

But did it ever occur to you that the show could come to you—that is, you might organize a show of your own and arrange things to suit yourself? If you want the Wild West Show first and a circus after you can have them. Should you prefer both shows at the same time they are yours, for you can make the entire affair—horses, riders, Indians, wild animals and tent. You may do even more—you can cause all the performers actually to move, and that by the mere turn of your wrist, because your show will be in reality the moving pictures of

#### A Panorama

Get a common old house-broom (Fig. 117) and saw the broom part off evenly from the handle at the dotted line A; then saw two pieces of equal length from the handle at dotted lines B and C,

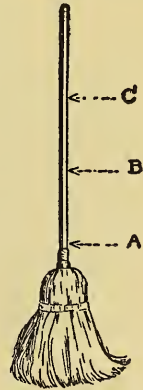

Fig. 117.—An old broom for rollers.

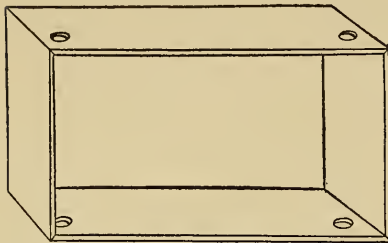

Fig. 118.—Box for show with holes in top and bottom.

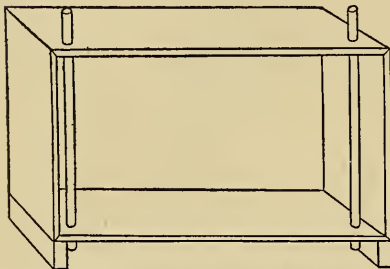

Fig. 119.—Broom stick rollers fitted in box.

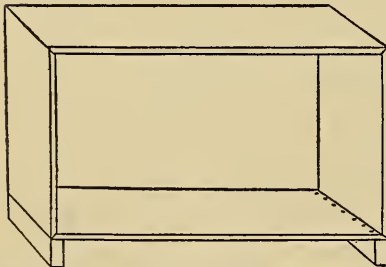

Fig. 120.—Blocks of wood across each end of bottom of box.

making each piece fourteen inches long. These we will call the rollers.

Find or make a wooden box about twelve inches high, eighteen inches wide and eight inches deep; carefully pry off one of the eighteen-inch sides and cut two round holes through the top of the box, one at each end, two inches from the front and one and one-fourth inch from the end; then turn the box over and cut corresponding holes through the bottom; reverse the box again, bringing the right side up (Fig. 118). The holes on the bottom must be exactly under those on the top and all four holes must be only large enough to allow the roller to slip in, and while in, to turn easily (see Fig. 119). Remove the rollers and nail a strip of wood two inches thick across each end of the bottom of the box (Fig. 120). Then hammer

two strong staple-tacks on each roller two and one-half inches from the top, or smaller end, and on opposite sides of the stick;



The Wild West Show Performance.



guide the tacks so they will incline very slightly upward while being hammered in (Fig. 121).

Fit an empty spool on one end of a piece of wood, one inch wide, three inches long and not less than one-fourth of an inch thick. Slide a large-headed screw in the hole of the spool until

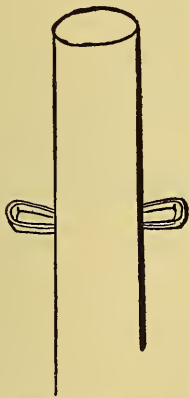

Fig. 121.—Tacks in roller.

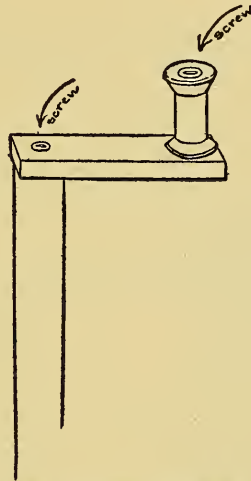

Fig. 122.—Spool on strip of wood for crank.

the screw rests on the block of wood; then screw it down tight, fastening the spool securely on the wood (Fig. 122); screw a second spool on another piece of wood of the same size as the first (Fig. 123, D and E). Fit the free end of the block of wood over the top of the roller and mark off the space on the block occupied by the end of the roller; with a gimlet bore a hole through the centre of this space, and also in the centre of the top of the roller; place the block of wood over the top of the roller, bring-

ing one hole on top of the other, and fasten the roller and block together with a screw. In like manner screw the other block to

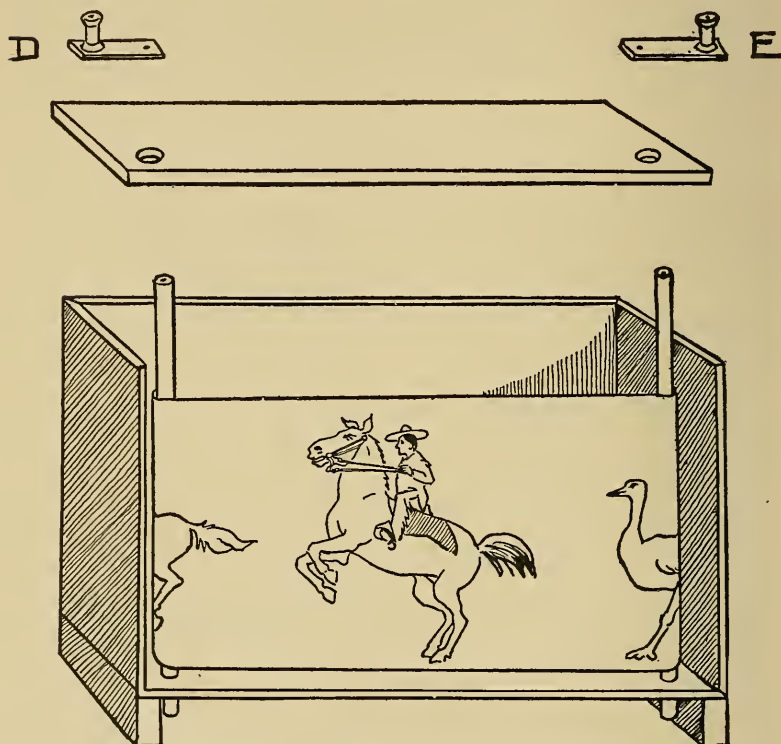

Fig. 123.—Top of box and the crank ready to be fastened on box.

the top of the second roller; these blocks and spools form the crank-handles for turning the rollers (Fig. 124).

Unscrew the blocks from the rollers and carefully remove the staple-tacks, in order that

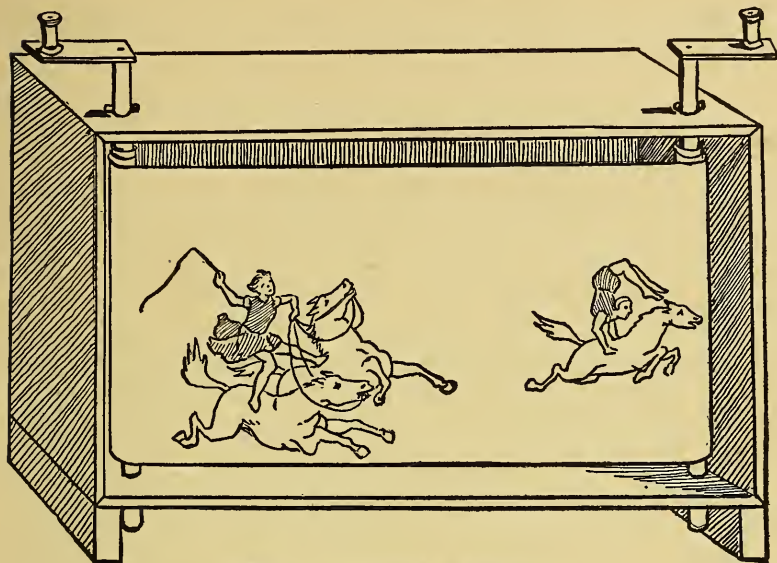

Fig. 124.—Box ready for tent front.

### A Strip of Cloth

may be tacked to the rollers and the rollers replaced in the box.

Purchase two yards of low-priced white cambric dress skirt lining; fold the cambric lengthwise into three equal divisions; then cut the folds apart, making three lengths each two yards long and about eight and one-fourth inches wide; sew the pieces together along the end edges, lapping one over the other that the seam may be as thin and flat as possible (Fig. 125). This will give you a strip almost six yards long for the panorama. Do not hem either the top or bottom. Allow a blank space

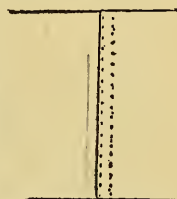

Fig. 125.—Lapped ends of strips of cloth sewed.

of white cloth, sixteen and one-half inches long, at the beginning of the panorama; then commence

### Pasting Pictures

on the strip. Colored newspaper pictures are best, because the paper is thin and easily pasted on the cambric. Almost all leading newspapers publish in their issues from time to time colored pictures of wild animals, rough riders, Indians and circus performers.

When you have a collection of the pictures you want, cut each one out neatly. When all are ready, sort them over, selecting the one you wish to come first on the panorama; then the second picture and so on. Have them all in order so you need waste no time hunting for a print while pasting the pictures on the cambric.

Make a good paste of flour and water, allowing it to boil well before using. A drop or two of oil of cloves mixed with the paste after it has cooked will keep it fresh a long time.

Select an attractive, comical picture for the first design on the panorama; but save the best and most startling picture for the very last.

You should arrange

### The Performers

in your panorama in much the same way as a story is written or a play put on the stage. Always begin with something which will cause the audience to want to see more; then paste on various pictures, but toward the last lead up to the best and most exciting design; the last picture stands for the climax in a story or a play.

When placing the pictures on the strip of cambric, remember



not to have them close together; keep them apart, allowing a little blank space between each successive object, so your audience will have an opportunity of enjoying every one of the performers and wild animals as it first appears peeping from behind the roll at one side of the tent, showing only its head, then coming in full view and passing slowly before them until it finally disappears around the roll at the other side (Fig. 123).

### When the Pictures Are All Pasted

on the strip, turn over and crease down half an inch of cambric along the edge of the first end of the panorama; tack this end on one of the rollers. If the thickness of the top of your box is one-half an inch, tack the end of your panorama fully four and one-half inches below the top or smaller end of the stick. Should the thickness of the lid be one inch, the cambric strip must be tacked on still lower—about five inches from the top.

You cannot be too particular about having the edge of the cambric perfectly even and straight on the roller, so the strip will lie at a true right angle to the roller when laid out flat (Fig. 126).

Having tacked the cambric on, gradually roll it around the stick, keeping the strip running over, not under the stick, so the roller will stand behind the cambric; have the cloth perfectly even as it winds around and around. When the end of the cloth is reached, turn in one-half an inch

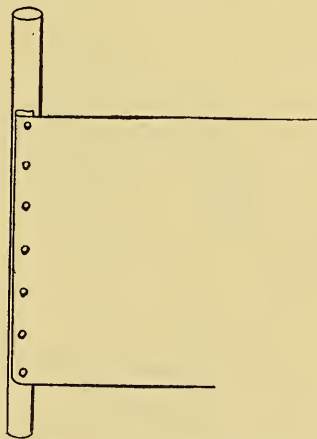

Fig. 126.—Cloth fastened on roller.

of the end edge and tack the cambric to the second roller as you tacked the beginning on the first roller (Fig. 127).

Use the same precaution and wind in the same manner but in an opposite direction when rolling the cambric on the second stick. With a strong hammer strike the top or lid of the box along the edges from underneath until it loosens and can be re-

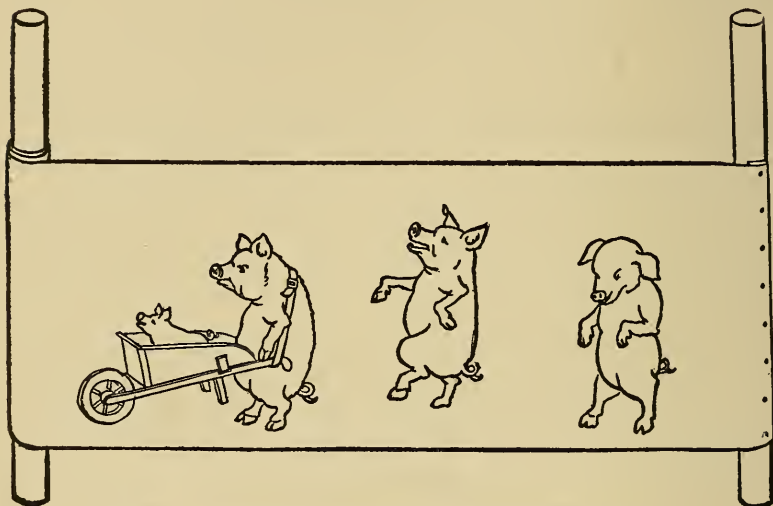

Fig. 127.—Method of rolling cloth on the broom-stick rollers.

moved; take it off and slide the rollers with the attached panorama into the holes on the bottom of the box (Fig. 123).

Replace the lid of the box, passing the top ends of the rollers through the holes, and nail the lid down to the sides of the box; then refit the staple-tacks in their respective places and see that they are in tight; restore the crank-handles on top of the rollers and rescrew them in position (Fig. 124). Now the panorama is ready to go into

### A Tent

Cut a stiff piece of pasteboard box like the tent design (Fig. 128) with an opening to fit the strip of muslin, spanning the space between the two rollers; the edges of the opening must cover both top and bottom edges of the cambric. Cover the pasteboard with white muslin cut into four pieces—one piece for the top, one for the bottom and one for each side. Cut the bottom piece into a strip to fit, slashed on all edges (Fig. 129, A). Paste this on the tent (Fig. 128) first,

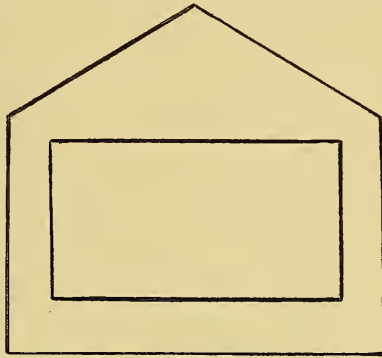

Fig. 128.—Pasteboard tent front for box.

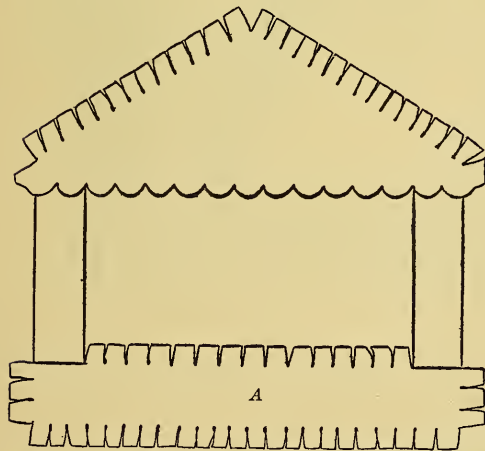

Fig. 129.—Manner of covering tent front with white cloth.

turning the slashed portion over and fastening it on the back of the pasteboard; then fasten a curtain on each side (Fig. 130) and paste the top piece of the tent on last; scallop this along the bottom edge and paste it only along the two slanting slashed top lines; turn the slashes over on the wrong side of the pasteboard and paste. When dry, fit the tent over the front

of the box and tack it firmly in place. Make three little flags of gay paper, paste on sticks and glue the sticks to the top peak and sides of the tent (Fig. 130); paste strips of paper over and



Fig. 130.—The Wild West Show with side curtains attached.

across the flag handle to the pasteboard to hold the flag more securely on the tent (Fig. 131). Your show will then appear to be moving inside of a white circus tent.

Set the box upon a table with the entire panorama wound

on the second roller, leaving only the blank portion of the cloth visible, and while the audience is seated in front, begin slowly turning the crank-handle of the first roller; at the same time telling in clear, well enunciated words all about your Wild West Show. Do not try to have your remarks sound as though learned from a book; that would be stiff and unnatural. Talk in an every-day way, exactly as though you were speaking only to your most intimate friend, and wanted to tell her all about the strange sights and queer people, and the funny bears who are not afraid of any man woman or child.

If you have been to a real Wild West Show, that will give you ideas, or if you have traveled way out West and seen the actual Wild West life it will be an inspiration for your show. Even to have read about the life with its daring riders, wild horses, buffaloes, hazardous stage coach drives, Indians and their war dances will be an immense help in aiding you to enter into the spirit of the show.

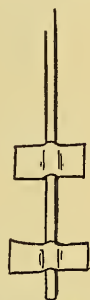

Fig. 131.—Method of fastening flag-poles on tent.



A Picnic on the Roof.

## CHAPTER XI

### ROOF PICNIC WITH BROOK TO CROSS AND FLOWERS TO PICK

**I**NVITE your friends to an afternoon picnic, and in the morning prepare the grounds for the frolic. Have a lot of growing flowers and growing fruit to give the place an attractive and festive appearance. The fruit must be real, not make-believe; it must be ripe and ready to pick; but the flowers may be of tissue paper, cheerfully bright and large in size. The aim should be more for general effect than detail in making these outdoor decorations.

#### Sunflowers

can be fashioned rapidly by cutting orange-colored tissue paper into strips twenty-five inches long and six inches wide, pointing

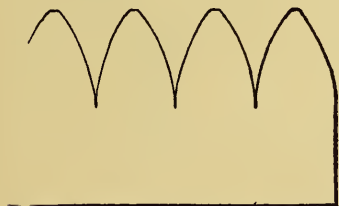

Fig. 132.—Cut the sunflower petals this way.

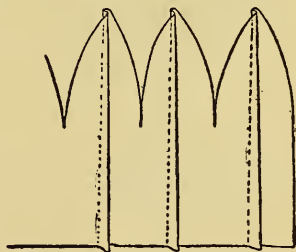

Fig. 133.—Fold each petal through centre.

the strips into petals three inches deep and two and a half inches wide at the base (Fig. 132), ten petals to each strip; then



Fig. 134.—Gather the strip of petals.

creasing each petal lengthwise through its centre to give stiffness (Fig. 133), and gathering each strip separately along its straight edge with needle and thread (Fig. 134); in this way forming the two strips into two pointed circles (Fig. 135). These circles, together with a brown centre, make one sunflower.



Fig. 135.—One gathered circle of sunflower petals.

Cut a strip of brown tissue paper nine inches long and two inches wide for the centre, gather the paper tightly along one lengthwise edge and tie it close up under and against the head of a slender nail (Fig. 136). Around the nail under the brown centre, slide on first one, then the other, circle of gathered yellow petals, taking care to have the petal points of the lower circle lie between and not over those of the top circle. Finish by driving the nail which runs through the sunflower, into



Fig. 136.—Sunflower centre.



Fig. 137.—Paper sunflower growing on broom-stick.



one side of a stick or broom-handle, with the lower end sharpened (Fig. 137).

### Hollyhocks

of every color can be made of circles of tissue paper five and a half inches in diameter, held at the centre, two circles one in-

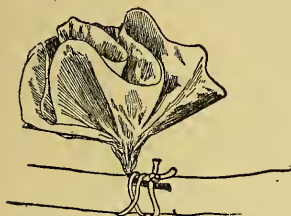

Fig. 138.—Paper hollyhock tied on stick.



Fig. 139.—Paper crimped for pinks.

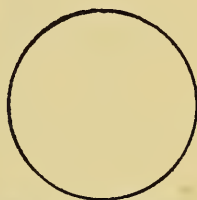

Fig. 140.—Paper disk for making poppy.

side of the other, and the centre pushed and squeezed together, causing the edges to fold and turn until they resemble the real flower (Fig. 138). Smaller circles, crimped by drawing the paper through the partially closed hand (Fig. 139), can be made into pinks, and you may have brilliant, nodding poppies in the same way, only these are of smooth, uncrimped circles (Fig. 140), placed one inside the other, with a small circle of dark-green paper for the centre, and all three layers pinched together at the extreme centre (Fig. 141). Large peo-

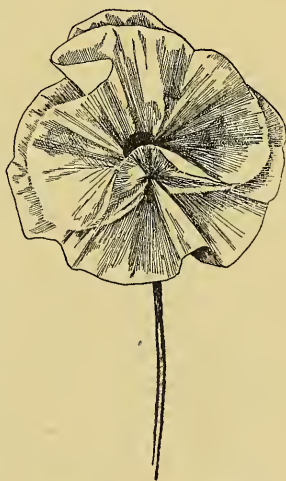

Fig. 141.—Paper poppy.

nies are similar in construction to some of the flowers you have made, so try to work these out yourself.

A simple way to make

### Roses

is to cut tissue paper into strips two and a half inches deep; cut the square-cornered slashes two inches wide, then with knife or scissors blade curl the sharp corners of each separate division, making the slashes into rose petals. Curl the corners of the petals along half of the strip inward, and those along the other half, outward. Fold two or three plaits in the straight bottom edge of each petal; then begin with the half where the petals curl inward and wind the strip around the end of a slender stick. The first petals form the central group and are curled inward; the remainder, curled outward, form the outward circle



Fig. 142.—Paper rose.

of petals (Fig. 142). Make a generous supply of blossoms and tie them on bushes. Let each bush bear but one kind, that the flowers may appear natural and as if actually growing.

### Get a Variety of Fruit, Peaches, Plums, Apples

or any other sort you may prefer. Tie the fruit to those bushes which have no blossoms, allowing each fruit bush to bear only one kind of fruit.

In case there are no bushes, or if the bushes are too few in number, use branches or sticks with natural foliage, or leaves

made of green tissue paper; make the latter of paper in several layers, that a number may be cut at a time like the pattern (Fig. 143). Crimp through the centre by folding lengthwise over a hatpin and pushing the folded centre together (Fig. 144). The method is quick and gives satisfactory leaves (Fig. 145). Cut leaves in different sizes as you will need some larger than others.

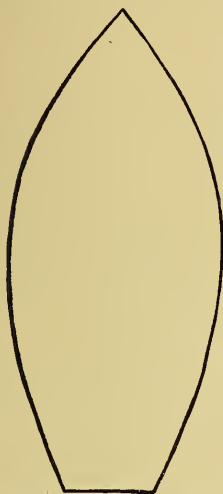

Fig. 143—Pattern for green leaf.

The sticks used as bushes should be of varying heights sharpened at the lower end and driven into the ground. Pretend the sticks are fruit trees and flower bushes and plant them where they will appear to best advantage. If your yard happens to be

### On the Roof

of the house, as often occurs in large cities, there will probably be no earth in which to plant things; then you must fill flower pots and deep boxes with earth, sand, or gravel, and plant your make-believe trees and shrubs in them; such a garden will be entirely different from all others.

Build a wooden fence over which the girls



Fig. 144.—Crimping green leaf.

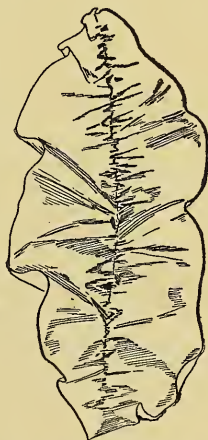

Fig. 145.—Green paper leaf.

and boys climb to enter the picnic grounds; even though the improvised fence may not closely resemble the real article, it will help to render the feeling of being in the open country more realistic.

Make the fence by sinking the legs of two strong kitchen chairs partially but firmly into the earth. Place the two chairs facing each other and a short distance apart; then run a large, strong pole or narrow board for a rail, across the chair seats, allowing the rail to extend out beyond the back of the chairs. Lash the rail securely to the chairs with the heaviest twine or slender rope, and place very heavy weights on the seat to keep the chair steady, and avoid all possibility of the rail slipping or chairs tipping.

If possible get either a swing, a teeter or a jogging board; all these will afford a lively time for your guests, as will also a wheelbarrow in which the girls and boys may take turns in riding and pushing or wheeling each other.

If you want to make the affair seem just like a regular

### **Country Picnic**

let each guest bring his or her own little basket of lunch.

As your guests arrive, usher them into the house and do not let them even see the yard if it can be avoided; keep the grounds for a pleasant surprise a little later.

Form the girls and boys into a single file and lead them marching around the room while they join in singing some lively air. After winding in and out among the chairs and tables, open the door, let them look out into the pretty garden, and, while still singing,

### **Climb Over the Fence**

and march among the flowers and fruit trees; end the procession by circling around the spot chosen for your dinner table, where

all must deposit their lunch baskets. Of course you will not have an actual table, as the tablecloth must be spread on the ground and the girls and boys sit around it.

Mark the four corners of the space reserved as a table with sticks about forty-six inches high, decorated with bright flowers (Fig. 146), and the sharpened ends planted in the earth, or in flower pots.

#### Spread the Tablecloth,

bringing each corner to meet a garland pole; then let the guests take from their baskets the different articles. Reserve some space at the centre of the table for fruit, and let each boy and girl in turn walk about the grounds and select one piece of fruit, pick it, bring it to the table, and lay the chosen piece on the centre of the tablecloth. No person may pick more than one piece of fruit during one turn. Each player is privileged to place his fruit in any way he desires, remembering always that each piece goes to form the centre-piece, which should always be made as decorative as possible.



Fig. 146.—The decorated pole.

#### Crossing the Brook

is a lively game and great fun. Get a number of flat stones that will lie steady, and are large enough to step upon; arrange them

about eighteen or twenty inches apart, in an irregular line, over a stretch of ground twenty or more feet across. Let the players in turn tip-toe on the stones just as though they were crossing a brook of running water, each girl and boy being obliged to pay a forfeit for every misstep into the make-believe water. If stones are not to be had, use blocks of wood, or, if need be, pieces of paper in place of stones. As each player crosses the brook, the rest of the party must call to her to be careful, not to fall, that she is going too fast, that she is going too slow, or make similar comments. They can cheer her, and in many harmless ways try to confuse the player with their calls, but it is against the rules to touch or even go nearer to her than two yards.

After all the girls and boys have taken their turn at crossing the brook, try

### Japanese Tag

Each player must keep her hand on the spot where she was last tagged, making the game present a most laughable appearance, with all the young people dancing about in strange attitudes, holding a hand on the top of the head, on the knee, chest, back, or foot, as it happens. The players are not allowed to remove the hand until tagged in another spot. When tagged in the middle of the back or any spot difficult to reach, the player may hold a stick in his hand with one end resting on the spot where he was tagged.

In starting

### The Game

any person who first shouts, "Pick her up and stone holder," may hold both hands in front of her, each doubled up tight and one clasp a small stone, immediately some one calls out "First

knock," another player cries "Second knock," another "Third knock," and so on, according as they are able to get the call in after the preceding cry. The player calling

### **"First Knock"**

taps one hand of the girl or boy holding the stone; if the hand touched contains the stone, the player knocking is "it," and the game begins, but if the hand is empty, the player is free and the stone-holder puts her hand back of her while she does or does not change the stone to the other hand; again stretching her clinched hands forward, she allows the player calling "Second knock" to try her luck by tapping one of the outstretched hands. The trials are continued until a player taps the hand holding the stone and becomes "it," then

### **The Others Scatter**

and "it" endeavors to tag some one, who in turn becomes "it," and so the game goes on.

After the players have grown tired of this game, there are many others which will suggest themselves to the young people, and it will be found a good plan to alternate the livelier kind with those of a more quiet nature.

When the picnic is over give each guest one of the pretty paper flowers to carry home, and your roof or back-yard picnic will have been an event long to be remembered.



The Magic Peep Show.



## CHAPTER XII

### THE MAGIC PEEP SHOW

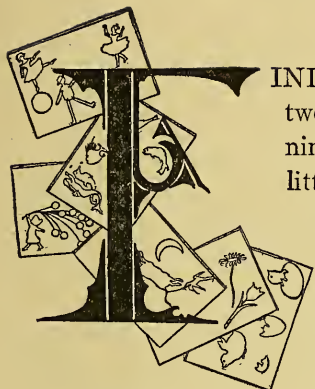

IND or make a simple pasteboard box, twelve inches long, ten inches wide and nine inches high, or you can have it a little smaller if you like, for your Magic Peep Show.

Cut a large square opening in the end of the box, leaving a margin one-half inch wide at the top and sides (Fig. 147). Make a small round hole in the centre of the front of the box,

only large enough for one eye to look through, and cut a slit a quarter of an inch wide on each side of the box half an inch

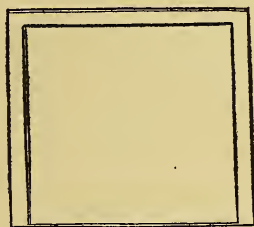

Fig. 147.—Back end of box opening.

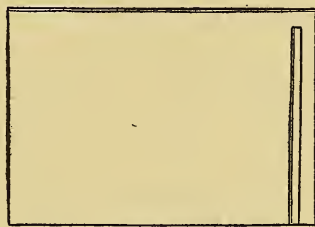

Fig. 148.—Slit cut in side of box.

from the open end and half an inch from the top; extend the slit to the bottom of the box (Fig. 148). Fig. 149 shows the box with the front, sides, and back cut.

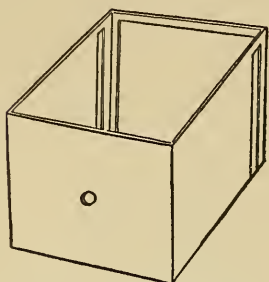

Fig. 149.—Peep-hole cut in front of box.

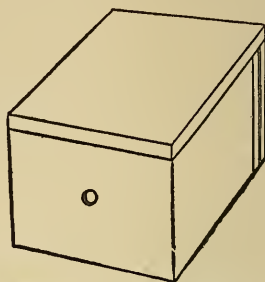

Fig. 150.—Peep show ready for slides.

If the bent-down edges of the box-lid are wide, cut them off within half an inch of the top; then put the lid on the box and it will be ready for the slides (Fig. 150).

### The Slides

must be stiff and perfectly opaque, so they will appear black when held up to the light. Make them of pieces of pasteboard boxes cut to fit in the side slits and long enough to extend a trifle beyond on each side of the box (Fig. 151).

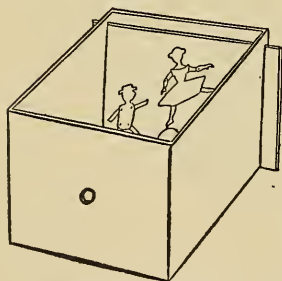

Fig. 151.—Slide in box.

Draw the different designs given here on separate slides, and with a sharp penknife cut them out, leaving holes in the slides exactly the shape of the designs. The holes should appear with clean-cut edges.

Of course, the complete designs on the slides must be drawn much larger than in these printed diagrams, but you can enlarge the drawings by the system of squares. Explained in Chapter XIV.

After the designs are cut out, paste colored tissue paper over

the openings, and when you look through the little hole you will see wonderfully bright and gay scenes all in transparent colors. An ambitious red cow will be found jumping over a yellow moon, and instead of being accompanied by the usual dish running away with a spoon, you will find an energetic wood sprite dressed all in Lincoln-green. The sprite has tied a rope of wild grape-vine to the cow, and, clinging to the rope, is sailing through the air and over the moon with his queer steed. Fig. 152 shows

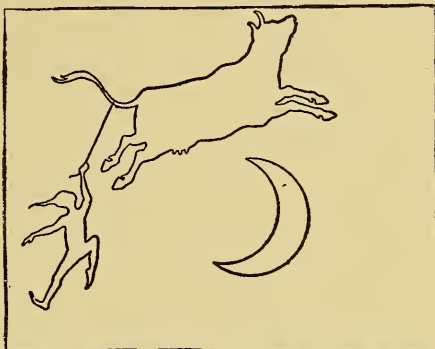

Fig. 152.—Cow jumps over the moon.—Front side of slide.

### “The Cow Jumped Over the Moon”

Cut out the group and paste a piece of dark-red tissue paper over the entire cow with the exception of the horns. Across these paste white tissue paper. Cover the moon with one piece of yellow tissue paper and the sprite with green, all except his face; have that pink. Cut out a thin line for the rope and paste a bit of brown tissue paper over it. Fig. 153 shows

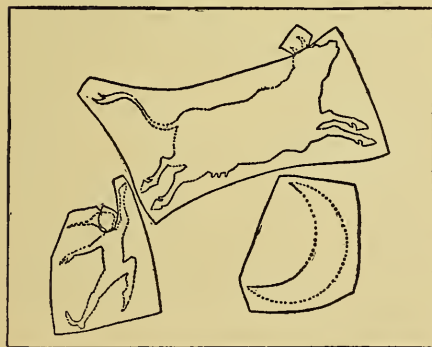

Fig. 153.—Wrong side of slide.

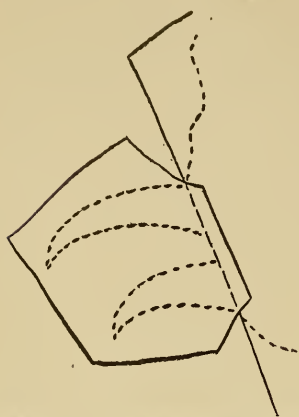

Fig. 154.—White paper over horns.

the wrong side of the slide and explains how the work is done; dotted lines designate the openings, which are covered with tissue paper, in the manner described.

The tissue-paper coverings may be cut in any shape, but each piece must cover well the opening of the figure or portion of figure intended to be the color of the paper. Have the white paper across the horns lap less than one-eighth inch over the red

paper of the cow (Fig. 154), and

manage the pink paper of the sprite's face in the same way where it meets the green of his cap and clothing.



Fig. 155.—The jumping cow.



Fig. 156.—The green sprite.

In making the other slides, follow this method throughout whenever two pieces of tissue paper come in contact on the figure, and when pasting paper over designs on the remaining slides always use one large piece of paper in preference to several small pieces for covering different parts of the design, which are the same in color. Figs. 155, 156 and 157 give



Fig. 157.—The moon.

the cow, sprite and moon for you to copy or trace.

### Life in Fairy Waters

Fig. 158 shows how dark the slides appear when seen in the peep show and gives an idea of the decided contrast of the light design against the dark background, only the black and white print

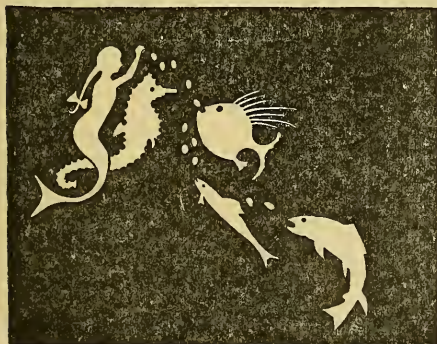

Fig. 158.—Life in fairy waters.

cannot give the charm of the clear, bright, transparent coloring of the mermaid feeding her many-hued pets as she rides her sea-horse in the fairy waters.

The different parts of the composition are Figs. 159, 160, 161 and 162, and the food merely little

oval-shaped holes covered with white tissue paper. Make the mermaid's hair and ribbon brown; her face, arms and body to the waist line, pink; the remaining portion of the mermaid's figure orange-color. The fish, scarlet,



Fig. 159.—Mermaid on sea-horse.



Fig. 160.—Fairy fish.



Fig. 161.—Fairy fish.



Fig. 162.—Fairy fish.

purple and white. Paste wee round pieces of black paper on the fish for the eyes.

As soon as you finish the slide, fit it in the peep show box, turn your face to the light, then peep through the hole and find how pretty the bright group looks with all the eager fish gathering around the little mermaid as she calls them to breakfast.

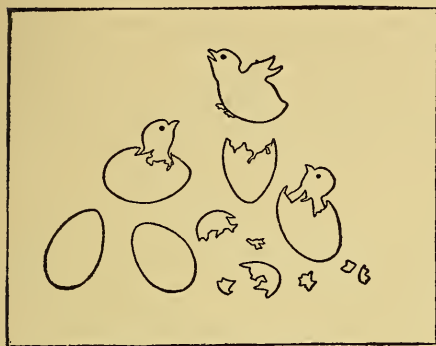

Fig. 163.—Easter chicks.

Next comes Fig. 163, the

### Easter Chicks

Make Fig. 164 light yellow; Fig. 165, blue; Fig. 166, orange chick, white shell; Fig. 167 A, green, B, purple; Fig. 168, white chick, scarlet shell; the broken shells (Fig. 169) red, blue and white. The poor little

chicks are glad to escape from the shells even though the shells have been gayly painted.



Fig. 164.—Light yellow chick.



Fig. 165.—Blue shell.



Fig. 166.—Orange colored chick—  
White shell.

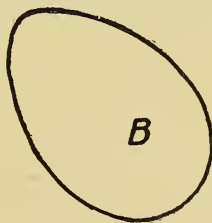
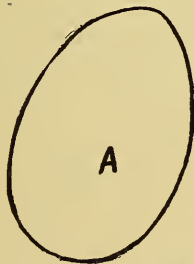

Fig. 167.—Green egg.—Purple egg.



Fig. 168.—Scarlet shell.



Fig. 169.—Pieces of red, blue and white shell.

### In the Three Blind Mice

(Fig. 170), which are pursued by the knife belonging to the farmer's wife, the first mouse can be orange-color; the second, white, and last one brown.

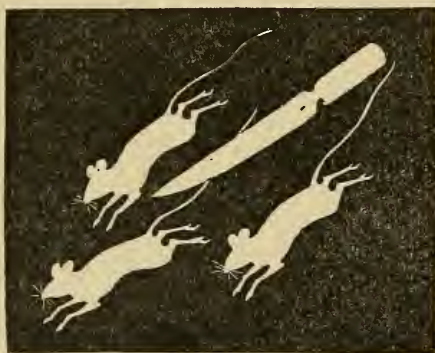

Fig. 170.—Three blind mice.

The blade of the knife, scarlet, and its handle green, or any other colors which may please your fancy. Remember, this is a magic peep show, and often the natural color of animals is changed to more brilliant hues in order to secure a more vivid effect.



Fig. 171.—One of the three blind mice.



You can make all three mice from one outline (Fig. 171) and the knife from Fig. 172. Set the slide of mice in place in the box, peep through the hole and "see how they run!"

The next illustration will undoubtedly prove to be the most

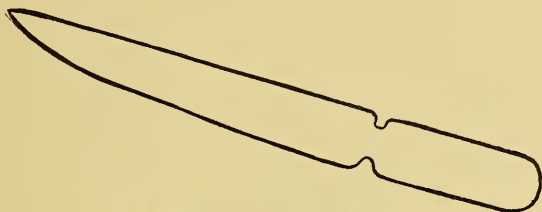

Fig. 172.—The butcher knife.

amusing of all, and will bring forth gales of laughter from your little brothers, sisters or friends. It is the

### Dance of the Dolls (Fig. 173)

On Fig. 174 paste orange-colored hair, a scarlet dress and green shoes; then over all paste one large piece of white tissue paper which will make the doll's face, neck, arms and stockings white.

The layer of white paper placed over these colors does not affect them in the least.

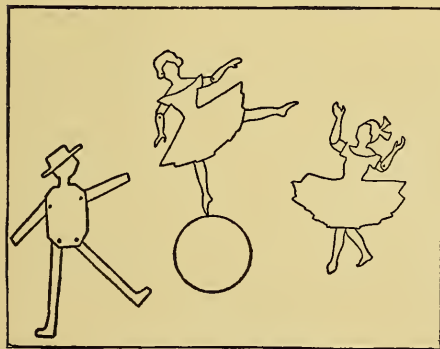

Fig. 173.—Dancing toys.

Cut a circular hole for the ball and cover it with brown tissue paper. Dress Fig. 175 in the same manner as the doll just described, but in other colors. For instance, make her hair

brown, her dress light purple, her shoes yellow, and her face, arms and stockings white. If you want features on the faces, use a very soft lead-pencil and draw eyes, nose and mouth, though



Fig. 174.—Girl to dance on ball.



Fig. 175.—Dancing doll.

features are not really necessary, and, as a matter of fact, the dolls look very well without.

Let Jumping Jack (Fig. 176) be all in blue, except his face—make that white. Joints on all the toys, as seen in the illustrations, are indicated by pasting thread lines of black paper and pin-head dots of black paper over the places where joints should be, according to the outlines and dots at the elbows of the girl dolls and the shoulders and hips of dancing Jack.

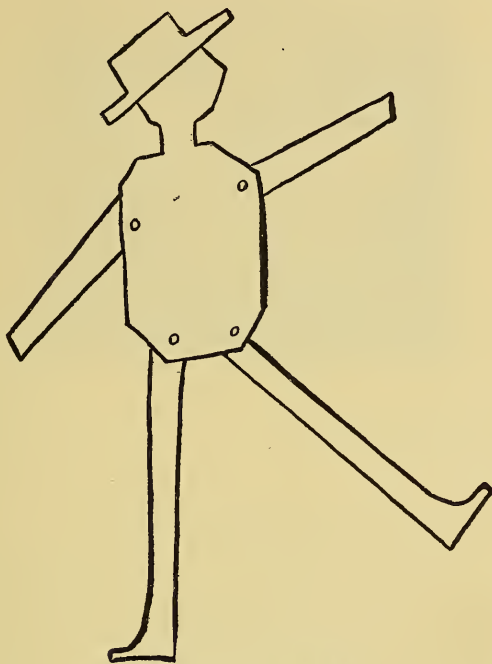

Fig. 176.—Jumping Jack.

### The Bouquet

(Fig. 177) consists of a red tulip (Fig. 178); a deep-yellow ox-eye daisy with a brown centre pasted over the yellow—in this case it can be done (Fig. 179)—a bluebell (Fig. 180); and a white daisy with yellow centre (Fig. 181). You will find that this piece, with all its bright colors, will be one of the prettiest of your designs. Fig. 182 is a branch of green leaves.

Cover each blossom with its respective color, and then paste one piece of green tissue paper over all the leaves and stems and the effect will be very natural.



Fig. 177.—Floral slide.



Fig. 178.—The red tulip.



Fig. 179.—Ox-eyed daisy.



Fig. 180.—Bluebell.



Fig. 181.—White daisy.



Fig. 182.—Green leaves.

### The Little Sun-bonnet Girl

(Fig. 183), playing with a lot of bright-colored balloons, forms the last slide. Make the little girl's dress blue, her sun-bonnet white and her hands, feet and ankles pink (Fig. 184). Let the strings of the balloons be of white tissue paper and each balloon of a different color from all the others; one may be dark red, the others green, pink, purple, light yellow, blue, scarlet, orange, brown, light green, white and vivid yellow. The slide will be very brilliant.

Invent other designs yourself. Think of some-

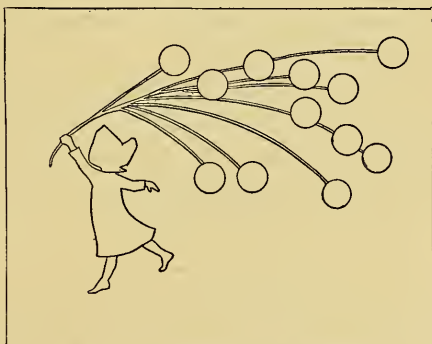

Fig. 183.—Little sun-bonnet girl.

thing you would like to see and try it on a new slide; when you succeed with one, you will want to make another and another. The more slides you have for your magic peep show the longer



Fig. 184.—Sun-bonnet girl.

the fun will last, and you will be able to give no end of pleasure to your little friends.

When exhibiting the peep show set the box on top of a table where the light will shine through the slides and let the party take turns facing the window and peeping through the little hole at the novel, brilliant scenes beyond.





Champion of the New Outdoor Game



## CHAPTER XIII

### PLANT YOUR GARDEN IF YOU CAN

#### A New Flower Game



RIGHT summer days are the time to be out of doors in the sweet, fresh air, with the birds and flowers, where there is plenty of space to run and have a good time. What a lot of games can be played in the open. There is Hide-and-Go-Seek, Catcher, Tag, Hop-Scotch and many more. You will be able to add a number to the list. Probably, though, you have played all of them over and over again, so we will try and think of something new. We must have a game that will be lively, interesting, and at the same time require a certain degree of skill, and the game must be one where we can enjoy the making of things requisite for the sport; but the material must not cost more than a few cents.

I have it! A game of flowers with roses that will not wilt or fade but last for a long time fresh and bright. We will call it "Plant Your Garden if You Can," because one cannot always be absolutely sure of planting the flowers, and that is part of the fun.

#### Two Dozen Roses

will be needed for this garden game, half a dozen white, half a dozen red, half a dozen yellow and half a dozen pink. The flowers are of tissue paper and very pretty.

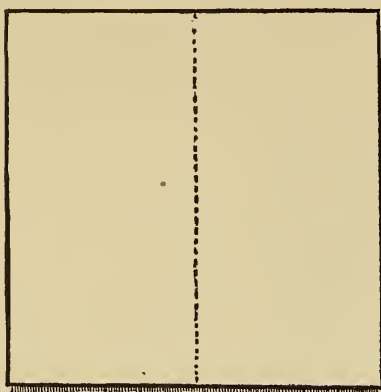

Fig. 185.—Square 12 inches each side.

Cut squares measuring twelve inches along each of the four sides, from white, pink, yellow and red tissue paper; the dotted lines on the diagrams indicate where the paper must be folded (Fig. 185). Fold each square across the centre (Fig. 186). Fold again crosswise through the centre, forming a small square of four layers (Fig. 187). Again fold, this time diagonally (A to B, Fig.

187), and you will have a triangle (Fig. 188). Fold once more diagonally (Fig. 188) A to C; this will give Fig. 189. Cut

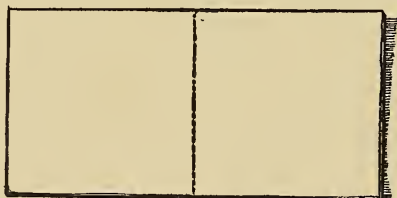

Fig. 186.—Square folded once across centre.

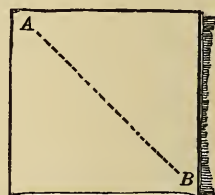

Fig. 187.—Square folded twice.

straight across from E to dot D (Fig. 189), then cut a slash an inch and three-quarters deep in the centre of the edges as shown by the line F in Fig. 190. Open out the paper (Fig. 191). The slashed edges will form the petals of the rose. Curl each corner edge of every petal with a blade of a pair of scissors according to dotted lines on the petal (Fig. 192).

Begin by holding one corner of one petal between the thumb of your right hand and one blade of the scissors; gently pull your

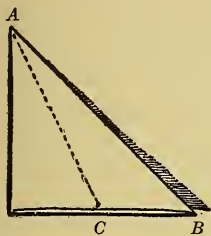

Fig. 188.—Four layer square folded diagonally.

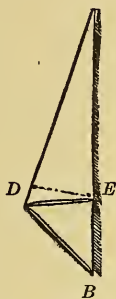

Fig. 189.—Triangle folded diagonally through centre.

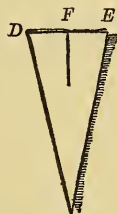

Fig. 190.—Second triangle slashed on edges.

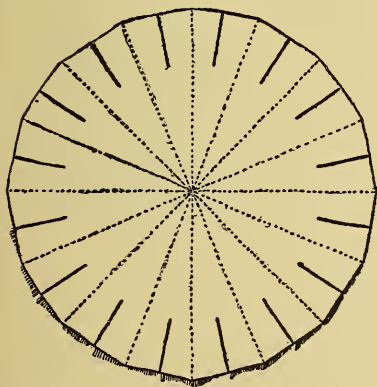

Fig. 191.—Unfolded triangle with slashed edges for rose petals.



Fig. 192.—Section of paper for rose showing one curled petal.

thumb and the scissors blade outward, sliding them along each side of the petal, while you hold the remainder of the paper steady with your left hand.



Fig. 193.—Two curled petals on each half of rose.

The thumb rubs over the petal; at the same time the edge of the scissors blade scrapes the under side of the petal, which causes the paper to curl. Fig. 192 shows one petal with both of the side corners curled. When you have curled around the first half of the circle, turn the paper over and curl the petals around the other half of the circle in an opposite



Fig. 194.—Flour in centre of paper and string around below rose petals.

direction. Fig. 193 gives two petals curled forward and two backward, representing two petals on each half of the tissue-paper rose. After all the petals are curled lay the centre of the tissue paper out flat and place on it three level tea-



Fig. 195.—Finished rose and flour bag.

spoonfuls of flour; then gather up the edges of the rose and wind a strong thread several times around below the petals and above the flour-bag formed by the centre of the paper (Fig. 194). Tie the string, adjust the petals and the rose will be finished (Fig. 195).

**Mark Out Two Flower Beds**

where the roses are to be planted. Each bed must measure three yards in length and one yard in width. The beds must run parallel to each other and be separated by a space of three yards. Each of the two flower beds must then be divided crosswise through the centre, making four flower beds in all, two on each side—one for every player. Fig. 196 shows the plan with flower beds divided. The circles denote the station points or places where the players stand, and the dotted line the direction the roses should take when played by the girl or boy stationed at the position marked "Barbara." The other players send their roses in like manner over the intervening space to the flower bed diagonally across from their position.

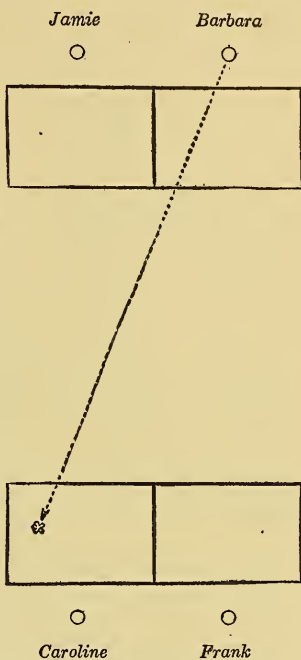

Fig. 196.—Plan of flower bed for game.

That there may be no mistake regarding each particular enclosure where the different-colored roses should be planted;

**Use Flags**

to designate the color of the various flower beds. From inexpensive cotton cloth of a solid red color cut a flag eighteen inches long and twelve inches wide; hem the raw edges; then tack one end of the flag on a slender stick one yard or more in length; sharpen the free end of the stick and push it down into the earth

at the outer back corner of the flower bed intended for the red roses. Have the flag stand straight and firm. Make a white,

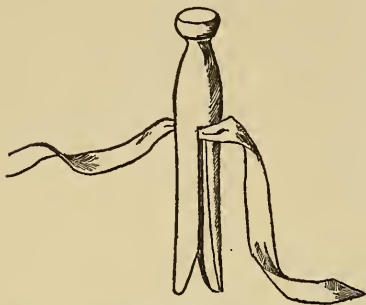

Fig. 197.—Tape in clothespin for pegging to ground.

a yellow and a pink flag in the same way. Erect each in the outer back corner of its own bed, which will be the bed where roses of corresponding color are to be planted. All the flags must be of equal height.

If the game is played at the seashore on a smooth, hard beach, mark out the flower beds by running the end of a stick along in the sand. If the game takes place on a level lawn, use white tape for marking the beds; peg the tape down to the earth with com-

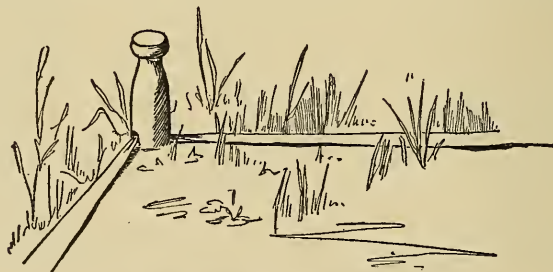

Fig. 198.—White tape outlining flower bed.

mon wooden clothespins (Fig. 197), first sliding the tape in the clothespin (Fig. 198).

### The Four Rackets for the Game

are ordinary flat palm-leaf fans, one fan to each player.

The game is played by sides, and calls for four players, two on each side.

### **The Game**

is that each player in turn shall plant as many roses in her own garden as she can. Every player has six roses of one color; the two holding respectively the white and the red roses are on one side, while the two with the yellow and the pink roses take the opposite side. When all is ready and the players are at their stations, a signal is given and the game begins.

The first player holds one of her roses out with the left hand, strikes it with the fan-racket held in the right hand, and endeavors to send the rose flying and land it in her own garden. If she succeeds, the rose is said to be "planted," and scores her one point, but should the rose go beyond the boundary line of her flower bed, fall short of it, or the flour-bag of the rose be broken, the play is a "failure" and scores one point for the opposite side. When a rose falls on the boundary line of its own flower bed, the play is a "fault," and the player may try again with the same flower. After the first player has had her turn, a player on the opposite side tries her skill, for the turns must alternate from side to side. The game ends with the playing of the last rose, and the side scoring the greatest number of points wins the game. All roses when played must remain where they fall until the close of the game, with the exception of those falling on the boundary line of their own beds.

### **A Tally Card**

will be required for keeping a record of the game. Make one of white pasteboard (Fig. 199). The initials can be changed to those taking part in the sport. Every point scored must be written under the color and initial or name of the person who scores it. When, because of the failure of one player, the oppo-

site side scores a point, the score must be recorded in the third column belonging to that side on the tally card under the word "Won."

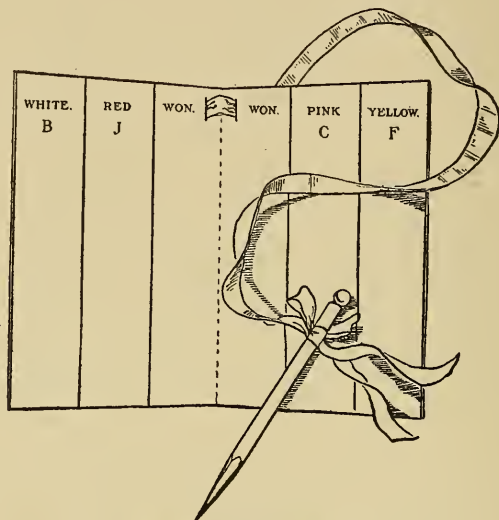

Fig. 199.—Tally card.

### To Determine the Choice of Sides,

which shall be first, and the distribution of colors, draw straws for the colors and toss for position of sides. To draw straws, take four straws of varying lengths, and grasp them in your hand in such a way that the extending ends of the straws seen by the other players are the same in length, while the uneven ends are closed within the hand; allow each player to draw a straw. The girl or boy taking the longest straw has first choice of colors; the player holding the straw next in length has second choice, and so on.

To toss for position of sides means that a player from each



side shall toss a small stone toward a stick laid on the ground two yards distant from the spot where the players stand. A twig placed on the spot may mark the point from which the stones are to be tossed. The stones must be tossed in turn, not at the same time, and the player whose stone comes nearest to the mark wins the right for his side to the choice of position on the grounds, also the right of first play.

One charm of this game is that the roses when volleyed by the players invariably land on the ground blossom uppermost, and these twenty-four bright blossoms scattered over the green lawn or sandy beach, with gay, colored flags outlining the four corners of the garden court, and, best of all, the group of merry boys and girls, make a very attractive and pretty scene.

The game, though intended for four players, may also be played by either two or eight players. When only two take part, each must play the twelve roses belonging to his side; in other respects the rules are the same as in a four-handed game. When there are eight players, four must stand on each side and each player have three roses, two players necessarily playing the same color, but not in the same bed, as the garden on both sides must be divided into four beds that every player may plant roses in a separate flower bed; otherwise the original rules hold good.

“Plant Your Garden if You Can” may be adapted to the house when chill Autumn days appear and the weather grows cold and rainy. When played indoors the beds may be marked out by white tape as on the green lawn, only in this case wooden clothes-pins would be of no use, and thumb tacks, such as are used by artists, must take their place to fasten the tape down on a bare wooden floor, and safety-pins when the floor is carpeted.



Fig. 200.—Home-made Santa Claus as He will Appear on Your Hearth Christmas Morning.

## CHAPTER XIV

### JOLLY LITTLE SANTA CLAUS

#### WITH HIS REINDEER AND SLEIGH



O you want to see—actually see!—Santa Claus seated in his sleigh filled with toys, and driving his famous reindeer? You may do so and have him come to your home. Even if there is no chimney and open fireplace for Santa Claus to climb through, the blithe little fellow can be induced to appear, sleigh and all, and he will keep his turnout standing perfectly still

that all the family may have a good, long look at him. But you must carefully follow directions and help Santa Claus get ready for your Christmas (Fig. 200).

It would be difficult to say positively how long Santa Claus has lived, or when he first made his appearance, but we all know just how he looks,

“His eyes twinkle, his dimples are merry,  
His cheeks are like roses, his nose like a cherry.”

We know that he is sure to come every Christmas, and the girls and boys look forward gladly to his visit. The little Hollanders

name our Christmas Saint Santa Claus, the same as we do, though sometimes we call him Kris Kringle. In England he is both Santa Claus and St. Nicholas, in Switzerland Samiklaus, in Russia he is St. Nicholas. But no matter by what name he may be called, he is always the same, always the jolly little fellow bringing good cheer to every one. Santa Claus takes great delight in driving his tiny reindeer and sleigh full of toys over roofs of houses for the special benefit of the girls and boys he knows, and that includes all of them.

Possibly Santa Claus will drive only two reindeer in his sleigh this year. He is willing, however, to bring them all if you wish.

An ordinary sled (Fig. 201) will do for the foundation of

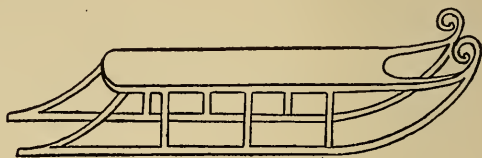

Fig. 201.—Ordinary sled.

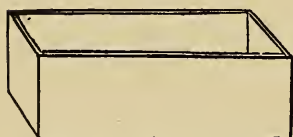

Fig. 202.—Box for top of sled.

### The Sleigh,

and a box for the body of the sleigh (Fig. 202) to set on the sled (Fig. 203). Find some furs to use as robes to hang over the sides and back of the

sleigh; any kind will do—boas, collars, circulars or rugs. Fit them in and over the sides of the box. If you have no furs, try plush or colored blankets. Tack gay-colored paper over those portions of the box which are not concealed by the robes, and lay a small, light

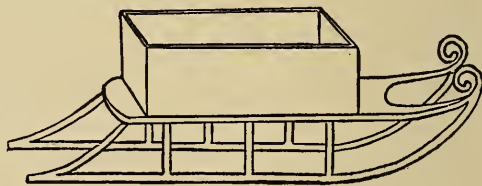

Fig. 203.—Santa Claus sleigh ready for fur robe.

board over the top front of the box, resting the ends of the board on the sides of the box to make the seat on the sleigh. Cover the board with the same paper as that tacked on the box.

Make two

### Reindeer

of stiff pastboard like Fig. 204. Now, do not think you cannot make the deer because you may not be skilled in drawing, for you can do so easily. Take a large sheet of paper and draw on it an oblong forty-eight inches wide and thirty-six inches high; divide the oblong into squares measuring six inches on each of the four sides, which will give eight squares in width and six squares in height. With the aid of these squares it will be fun to copy the reindeer. Number the side lines of your oblong and letter the top and bottom lines as in Fig. 205. Examine the lower corner space of Fig. 205 enclosed by the lines A-5, and you will find the hind hoof and part of the hind leg stretching diagonally across the space. Use a soft lead-pencil and begin copying the deer by drawing a slanting line from the extreme outward lower corner upward about one-third of the distance from the bottom to the top of the space A-5. This short slanting line forms the bottom of the hoof, the little space, enclosed between the hoof and the long toe above it reaches very nearly to the centre of the lower part of the square A-5. Make yours so. Draw the upper edge of the long toe; then run a slanting line up to the top line of the square space A-5, and make it touch the top line 5 less than one-quarter the distance from the side line A to the op-

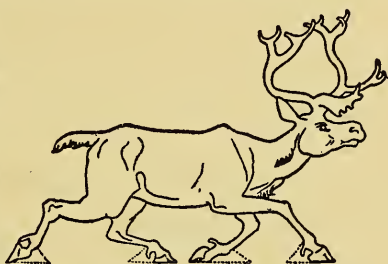

Fig. 204.—Extensions on each hoof.

posite line of the same square. Return to the lower part of the hoof already begun and draw the inside line of the hoof and portion of the leg in the same space, A-5.

In the space 4-5, immediately above the space A-5, you will perceive that only a lower corner is drawn in and that all the

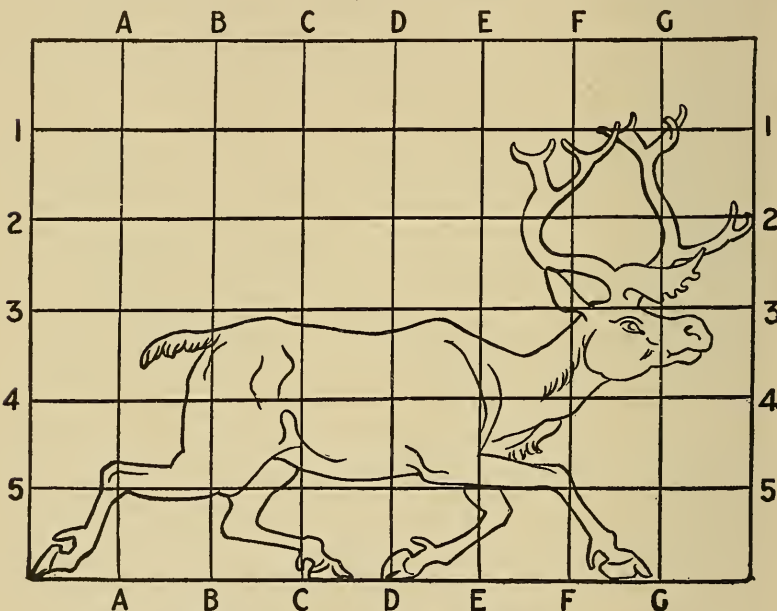

Fig. 205.—Reindeer enlarged enclosed in squares.

four squares above the square 4-5 are vacant, so continue your drawing on the bottom space A-B. The extreme upper corner of this is cut off by a short straight line; then a shallow scallop extends entirely across the upper part and runs into the third lower space B-C. If you notice closely the space enclosed by the lines 4-5, A-B, immediately over the one you have been work-

ing on, you will see that the corner on the line 4-A is vacant, while all three of the other corners are occupied by portions of the hind leg, and that the empty space extending from the vacant corner 4-A forms almost a square with two lines slightly curved and the corner diagonally across from the vacant corner 4-A, on the line 4, cut off by a short line bent bow-shaped. Draw it in the same way over the corresponding space on your paper.

Look at Fig. 206, following the line on the space 4-5, A-B, and you will discover that it is the same as in Fig. 205, only smaller, and by carefully comparing the two diagrams, Fig. 205 and Fig. 206, you will find the lines are formed alike in each, differing only in size; thus you will understand how

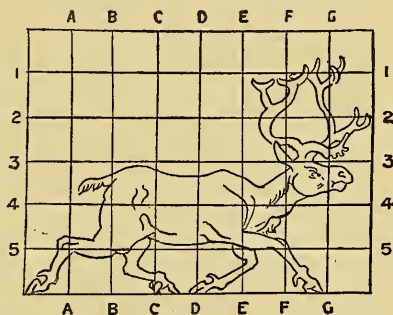

Fig. 206.—Reindeer enclosed ready to be enlarged.

you can make your deer very much larger simply by drawing it on larger squares. Continue as you have begun, taking one square space at a time, and copy on your large squares the outline of the entire deer as given on the squares of Fig. 206.

When the drawing is finished, go over all the pencil lines which form the deer with black paint or ink, making the lines heavy and plain, that they may be seen from across the room. As soon as the paint is absolutely dry erase the pencil-lined squares.

To make sure that the deer will stand firmly, extend downward a slanting line from the top of each hoof and draw another level line out from the bottom of each hoof to meet it, according to dotted lines in Fig. 204.

Cut out your deer and with pins or thumb-tacks fasten him

out flat on another large sheet of paper; then with the soft lead-pencil run a line on the paper around the deer, which will give

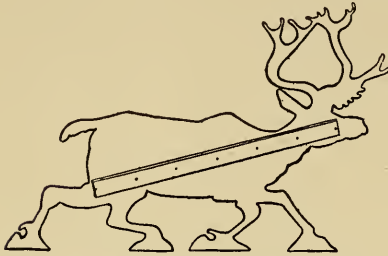

Fig. 207.—Reindeer re-enforced by strip of wood.

you the second deer; outline the markings on this like those on the first deer; then cut it out. If you want six deer for Santa Claus' sleigh make them as you did the second deer. Back each deer with very heavy, stiff pasteboard and nail a thin strip of wood on each of them. Let the wood reach

from the middle of the head to the edge of the hind leg (Fig. 207). Fasten the two animals together with three narrow flat sticks tacked across from deer to deer, one stick at the centre and one on each of the two ends of the slanting strips of wood fastened on each deer. The framework will then rudely resemble an inclined ladder. Stand the reindeer in front of Santa Claus' sleigh and see how fine they look.

To represent

#### Santa Claus,

make a large rag doll stuffed with straw or excelsior. It is not necessary to spend much time on making the doll, as it will be used only once, and will then be almost entirely covered, showing only the upper portion of the face for which you can mark easily with features. Make the boots (Fig. 208) like stockings

black muslin; have them long and loose enough at the ankle to form wrinkles. The trousers (Fig. 209) should be of scarlet cotton flannel, fleece side out; the coat (Fig. 210) cut of the same material; the cap (Fig. 211) of the red cloth cut melon shape, and sewed together. Santa Claus' costume must be



trimmed with bands of fur. Ermine will look best, and it is easiest to make. Cut strips of white cotton flannel and mark



Fig. 208.—Santa Claus' boot.

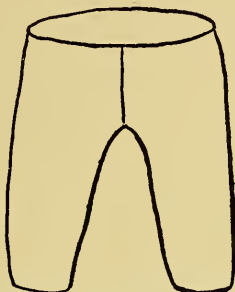

Fig. 209.—Santa Claus' trousers.



Fig. 210.—Santa Claus' coat.

them with black ink to represent the little black elongated spots on real ermine. Trim the tops of the boots (Fig. 208), the neck,



Fig. 211.—Santa Claus' cap.



Fig. 212.—Cap trimmed with ermine.



Fig. 213.—Santa Claus' wig.



Fig. 214.—Santa Claus' whiskers and eyebrows.

sleeves and edge of the coat (Fig. 210) and edge of the cap (Fig. 212) with fur. Make the wig of raw white cotton, and fasten it on the doll's head (Fig. 213), then the beard, moustache and eyebrows also of raw cotton (Fig. 214), and glue them on the face. Paint Santa Claus' face pink, his cheeks and the end of

his nose bright red, and his eyes blue. When dressing him, bring the fur-topped boots up over the trousers (Fig. 200).

With tacks and string fasten Santa Claus in an upright sitting position on the seat of the sleigh. Tie a long, narrow red ribbon around the neck of each reindeer and pin or tie the ends of these ribbon reins on to the mitten-covered ends of the arms which form his hands. He will then seem to be gayly driving his reindeer.

Fill the box of the sleigh with

### Christmas Gifts

wrapped in bright colored tissue paper. Any article liable to break should receive special attention. A cup and saucer (Fig.



Fig. 215.—Christmas cup and saucer.

215) is one of the most difficult articles to manage, and if you can wrap this up, properly, the wrapping of all other gifts will be easy.

Take the saucer first, place it on the centre of a piece of tissue paper (Fig. 216), fold the paper up around it, bringing the ends together at the centre (Fig. 217). Do the same with the cup (Fig. 218); then crush down the top of the paper over the saucer and set the paper-covered cup on it (Fig. 219). Now place the two on more paper and wrap up both together (Fig. 220).



Fig. 216.—Saucer in centre of tissue paper.

If there are not enough gifts to fill the box of the sleigh, open newspapers and crush them into the bottom of the box to fill up



Fig. 217.—Tissue paper over saucer.



Fig. 218.—Cup in tissue paper.

the extra space; spread white paper over the top of the newspapers, and fill in with the prettily wrapped gifts. Each parcel should be tied with a ribbon and decorated with holly, mistletoe or evergreen (Fig. 220). Cover the top of the paper parcels with



Fig. 219.—Wrapped cup and saucer together.



Fig. 220.—Cup and saucer ready for the sleighs.

various toys (Fig. 200), and Santa Claus with sleigh and reindeer will be ready to surprise the family early Christmas morning.

Try to have as many home-made gifts in the sleigh as possible.

### Your Christmas Cards

can be plain white pieces of cardboard decorated with the head of Santa Claus made of an almond on which is inked a face; the long hair and beard of refined white cotton being glued on the nut and a red peaked cap fastened on the top of the head; this makes a fine Santa Claus. The head should be glued on the left side of the card, and on the blank portion should be inscribed the greeting, "Merry Christmas."

## CHAPTER XV

### A LIVING CHRISTMAS TREE



HIS Christmas tree is not planted in a tub or fastened to a stand; it does not remain just where it is put, neither is it attached to a mechanical device that makes it whirl and spin around dizzily as they sometimes do in the shops. It is a living Christmas tree, a green Christmas tree all covered with glittering ornaments and bright colored toys, with little bells at the bottom that tinkle musically as it moves, and on the topmost point a brilliant star that sends out tinsel rays from every point. Then, a little distance below the star, a face—a laughing face with shining eyes that reveal the guardian angel of the tree.

You can keep the preparation of the living tree absolutely secret and make it a complete surprise, for it does not have to be set up where all may see in order to be decorated, and no hint of its existence need be given until the time arrives, the door is thrown open and the beautiful, sparkling Christmas tree glides slowly into the room.

#### How to Prepare the Living Christmas Tree.

Choose quite a tall girl for the angel of the tree and from dark green, undressed cambric cut a long, plain cloak that will fit smoothly over her shoulders and hang like an inverted cornucopia from neck to feet.

**Make the Peaked Hat**

out of stiff brown paper, cutting it like Fig. 221, and pasting it together like Fig. 222. Cover the hat with some of the green cambric, allowing a cape of the material to fall from hat to shoulders at the back (Fig. 223). Get three or four quires of moss-green tissue paper, cut it into strips six inches wide and cut each strip into rather coarse fringe, leaving a solid strip for heading at the top, two inches wide. Beginning at the bottom sew the fringe around the cloak, allowing it to reach just to the edge of the cloth.



Fig. 221.—Cut the hat after this pattern.

Above the first row of fringe, and overlapping it, sew the second row, bringing its lower edge within three inches of the bottom edge of the first row.

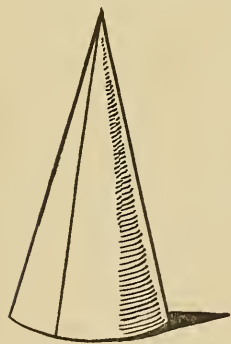

Fig. 222.—Paste it together like this.

In this way put on row after row of fringe, always overlapping it, until the cloak is entirely covered, then cover the hat and its cape in the same manner.

Take a light wooden hoop—one of the kind the children roll on the pavements in “hoop time,” and, turning the edge of the cloak up once, fit the hoop in the fold and hem the edge over it. This will hold the cloak out firmly at the bottom and it should hang smooth and straight from the shoulders with a generous lap where it closes in front.



The Living Christmas Tree.

INVENTED BY  
ADELIA B. BEARD





Pin the fronts together, leaving an opening only large enough to slip over the head.

Now suspend the cloak on a waisthanger in such a way that you can reach it from all sides, and proceed

### To Decorate

Around the bottom sew a row of small bells, and here and there all over the cloak, sew large dress hooks, on which to hang the fragile glass ornaments and small presents. Pin on the tinsel decorations and strings of popcorn with safety pins and leave the finishing touches until the angel has entered her tree.

The tall hat, tipped by its bright star, may be completely trimmed and put safely away until needed. All decorations and presents must be light in weight.

On the eventful night let the Christmas tree angel slip into the tree, and, after it is nicely adjusted, hang around her neck strings of colored glass balls, and suspend from the hooks the glass ornaments and presents. Put the peaked hat on her head, and the living Christmas tree will be ready for her triumphant entry. To avoid the danger of accident do not allow the tree in a room where there are unprotected gas lights, candles or open fire, and let the cloak be put on the angel in a room adjoining the one in which she is to appear, for going up or down stairs incased in the cloak is not to be thought of.

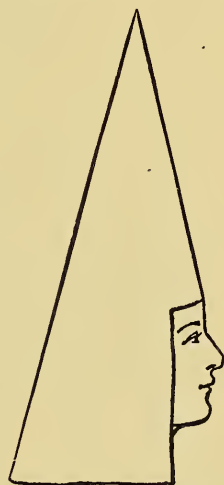

Fig. 223.—Cover the hat and leave a cape of the material.



One of the Booths at the Girls' and Boys' Fair with Articles Made by Themselves.

## CHAPTER XVI

### HOW TO GET UP A GIRLS' FAIR



LET two or three young friends help you get up the fair. Tell them that this is not to be an ordinary fair, it will be more interesting and unique; that buyers will find things which cannot be purchased elsewhere for any amount of money, as all articles for sale and even the decorations will be made by the girls and boys themselves, and duplicates are not to be found in the stores. Inform the young people that a prize will be given to the girl and to the boy whose work is the best.

#### Form a Managing Committee

and talk over arrangements with them.

If the fair is to be large, you will need either one large room or several small ones.

When the question of place has been settled to the satisfaction of all, make out a list of the various girls and boys who will help with the entertainment, and divide the list into as many parts as there are young people on your managing committee, including yourself. Give each member of the committee his or her portion of the list, with instructions to see every person whose name is on the paper and find out what each particular one will promise to make for the fair. Do not confine the soliciting to

young people of your own little circle, ask for contributions from all the girls and boys your managing committee are able to reach. Some may want to make several articles each, others may wish to do the decorating, and so on. Space must be provided on the list

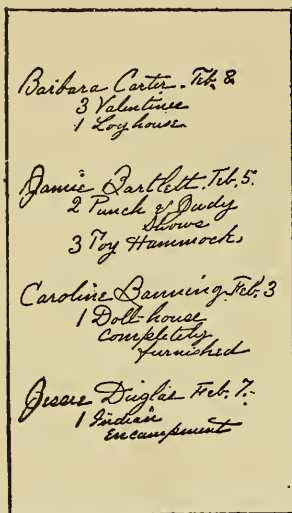

Fig. 224.—List of promised articles.

of names for writing down under each name the articles promised (Fig. 224).

Let each contributor understand that every article sent in must have the name, age, and address of the sender written in ink and fastened securely on each separate article, that every girl and boy may receive full credit for what she or he has made (Fig. 225).

In addition to the attractive booths you should have the ever popular grab-bag and the

“Four and twenty blackbirds  
Baked in a pie”

will be just the thing.

Take an ordinary wooden tub (Fig. 226), cover the outside with gay tissue paper laid on in flat plaits from top to bottom. Paste the paper along the inside of the top edge, carry it over on

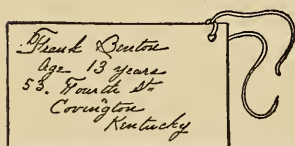

Fig. 225.—Card ready to attach to one article.

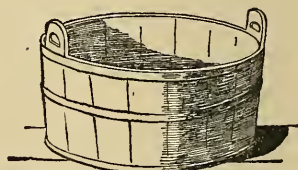

Fig. 226.—A tub like this for the blackbird grab-bag.

the outside down under the bottom edge. Cover the handles with the same paper, and fasten ribbon bows on the outside of the handles (Fig. 227). If the tub is covered with pink tissue

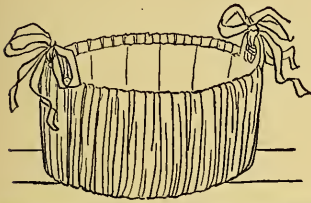

Fig. 227.—The grab-bag tub covered with colored paper.

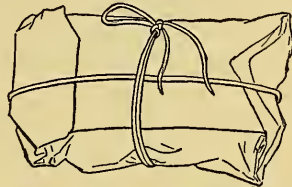

Fig. 228.—Package ready for grab-bag.

paper, tack pink ribbons on the handles; if red paper is used fasten green on the handles.

Fill the bottom of the tub with large, lightly crushed pieces of newspaper, cover these with a double layer of smooth paper, leaving sufficient space at the top for a layer of sawdust, bran or sand, deep enough to cover the different sized articles intended for the grab-bag. Each separate article must be wrapped in paper and tied with a string (Fig. 228).

Make as many

### Blackbirds

as you can place conveniently, without too much crowding, on top of the pie.

Use medium stiff cardboard or smooth water color paper, not

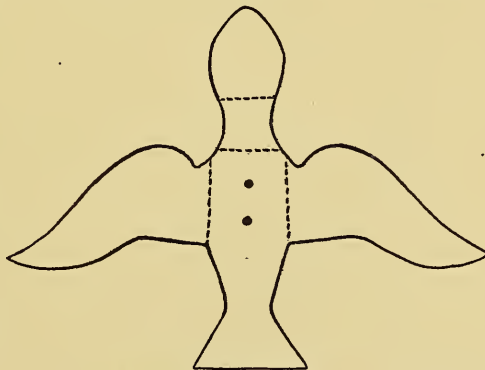

Fig. 229.—Pattern of blackbird.

too limber, for the birds. Cut them from an enlarged pattern of Fig. 229, as the birds must be life-size. Paint or ink the bird black on both sides and, when it is dry, bend up the tail in a curve. Bend up the neck at dotted line of Fig. 229. Pinch together the beak and bend it downward, bringing the head forward at dotted line of Fig. 229. Turn up the wings according to



Fig. 230.—Blackbird bent in shape.

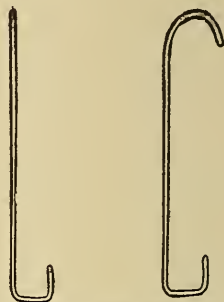

Fig. 231.—Bend one end of a hairpin into a square hook.

Fig. 232.—Top of hook bent into handle.

dotted lines on Fig. 229, and curve them over and outward at the top (Fig 230). Puncture two holes in the back of the bird at the dots A and B (Fig. 229).

There must be a handle for lifting the blackbirds; make it of a hairpin. Bend one end of a wire hairpin into a square hook (Fig. 231) and slide the longer end up through the foremost hole on the underside of the bird; tie the centre of a string, nine inches long, on the horizontal bend of the hooked end of the hairpin; then push the short end of the hook up through the other hole in the bird, bringing the string up close against the bird's breast. Bend the short end of the hairpin down on the bird's back and flatten it with a hammer. Curve the top of the hairpin

into a handle (Fig. 232) and fasten the hooked end of the hairpin more securely to the breast and back of the bird by pasting a

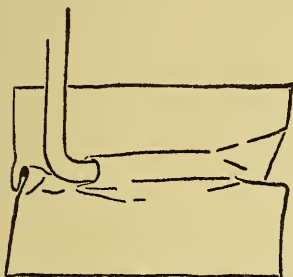

Fig. 233.—Hairpin fastened to back of bird.

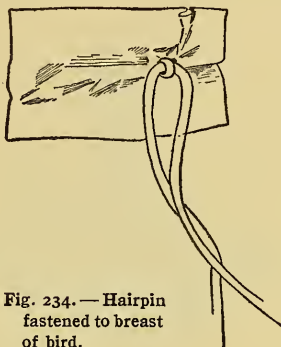

Fig. 234.—Hairpin fastened to breast of bird.

piece of paper over the short portion of the hairpin lying over the back (Fig. 233). Push the paper up tight around the edge of the wire. Paste another piece of paper over the short length of hairpin on the bird's breast in the same manner (Fig. 234).

Set the blackbird away until next day, when it will be perfectly dry, and you will find the hairpin secure in its place, standing straight and steady.

Tie the two ends of the string together into a hard knot; then bend one half of another wire hairpin into a hook (Fig. 235) and fasten it securely on the string at the end of the loop; twist the long handle of the hairpin hook (Fig. 235) around and over the string, as shown in Fig. 236.



Fig. 235.—Make a hook of another hairpin.



Fig. 236.—Fasten the hook to the string.

Instead of making one complete blackbird at a time, it will be much quicker and easier to make a pattern and cut out all your blackbirds first; then ink or paint them all, and continue working on them in this way until all are finished about the same time. It will not take long when once you have the pattern enlarged, and you can make the pattern the proper size by the system of squares, large and small, as explained in Chapter XIV.

When the birds are made and ready for the pie, hook

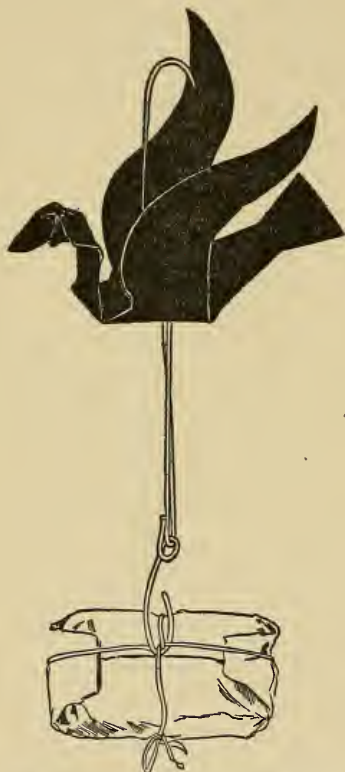

Fig. 237.—Blackbird with package ready for pie.

#### A Package on Each Blackbird

(Fig. 237), and hide the parcel and string down under the sawdust, resting the bird on top of the pie; then when any one wants to purchase a "grab" let him lift any bird he chooses from the pie by means of the hairpin in the bird's back.

The girl or boy in charge must take the parcel from the hook, give it to the purchaser, quickly slide another package on the hook and sink it down in the pie in place of the first one. While the purchaser is left entirely free to choose, she should take care not to disarrange the packages in the pie.





The Blackbird Pie.

Extra packages must be kept in a covered box or basket at one side, back of the "Blackbird Pic."

Another original idea for your fair will be

### **The Express Office**

At this table each article must be daintily tied up in white paper and the package labelled with the Christian name of one of the young people. Wrap up a number of articles that your friends may find parcels waiting for them when they call at the express office. The packages should also bear the name of the city from which they are supposed to have been sent. For instance, if you have a friend named Mary, and Mary happens to be acquainted with some young people in Cincinnati, mark the parcel for her with the name Mary and the place Cincinnati, Ohio. The addition of the name of some city will add greatly to the interest and excitement when the package is received.

Though a package may be intended for a certain person, any one with the same Christian name may purchase the article, but it cannot be sold to a buyer bearing another Christian name, and should some one come for an express package and the express agent be unable to find a parcel labelled with the purchaser's name, the would-be buyer must leave the office empty-handed.

The uncertainty of finding a package at the express office lends a certain charm to this table, for every one will feel some curiosity to ascertain for a surety whether he or she is included with the fortunate ones whose names appear upon packages.

Arrange all your articles for the express office in alphabetical order, those on one side of the table for girls, and on the other side for boys; then the parcel bearing the name called for may be quickly handed out to the inquiring purchaser.

### **Letters to Girls**

and letters to boys are easy to write. Ask as many friends as possible to write one or more letters to any companions they choose whom they think will attend the fair. The letters must be signed by fictitious names, never the writer's own name or the name of any real person; then those receiving the missives will have the sport of trying to find out which of their friends actually wrote the letters.

Several days before the fair opens all the mail, after being addressed and sealed, should be sent under additional cover to you personally.

### **The Post-office**

must be made very attractive, though it need not occupy much space. A mere corner of the room screened off with dividing drapery of turkey-red cotton cloth or any gay material will answer the purpose. Open the drapery at the centre division and make a three-cornered tent-like window in front between the two curtains with the aid of a chair. Place a box on the chair reaching to the top of the chair-back, set the chair between the two curtains, turn its back toward the people and cover it with the same material used for the curtains; then pin this drapery to the curtains on each side.

### **The Decorations**

must be very simple and inexpensive; something which can be made easily and quickly, and when finished they should be bright and effective.

Have your decorating committee cut a number of flags from different colored tissue paper or low priced muslin varying in length, anywhere from ten to fifteen inches, and in width from five

to nine inches (Fig. 238 and Fig. 239). If the ceiling is very high the flags may be larger.

Paste the straight dotted edge of each flag over a strong string long enough to extend in a graceful loop from the centre of the



Fig. 238.—Pattern of flag.



Fig. 239.—Pattern of pennant.

ceiling to the side wall (Fig. 240). Place the flags about twelve inches apart on the string and make four strings to reach to the four corners if the room is small, if large, a dozen or more flag-

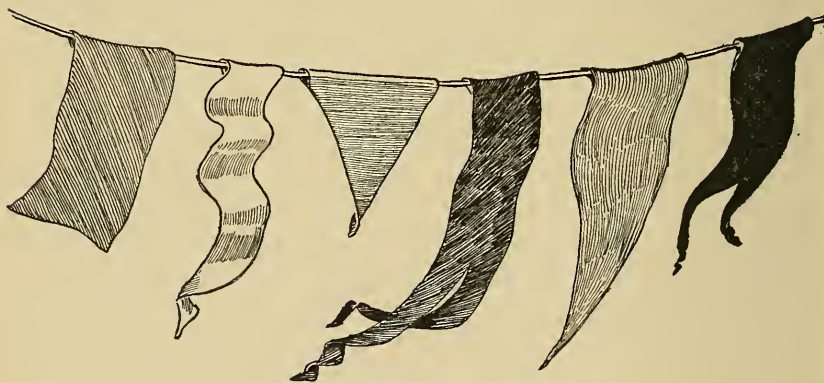

Fig. 240.—Flags for decoration.

strings, according to the size of the room. Have a generous supply.

Tie one end of each of the flag-strings close to the ceiling on the chandelier or lamp hook. Wind an extra string tight around and over the string-knots on the chandelier to hold the

strings in place and keep them from slipping down. Tie the free ends of the flag strings to picture-hooks and fasten the hooks on the picture-moulding. In this way you can obtain good results without the slightest injury to the walls. Should there be no picture-moulding, fasten the strings to large, strong tacks or small wire nails driven in on the top ledge of the window and door frames where they will do no harm.

Fasten extra strings from top of window and door frames, and



Fig. 241.—Fringe cut for tassel.



Fig. 242.—Winding top of fringe into tassel head.

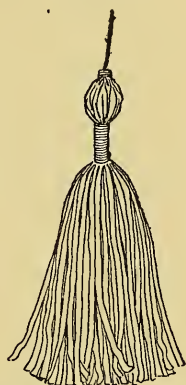

Fig. 243.—Tassel ready for decoration.

draw them taut along the walls, then tie the intervening flag-strings on these and the effect will be much the same as with picture-moulding, almost like a tent of small flags.

Hang a long, gay tassel on the wall at the end of each flag-string. Make the tassels of bright tissue paper. Take the once folded sheets of the variously-colored tissue paper as they come from the store, and cut them into long fringe, lengthwise of the folded sheets (Fig. 241), making each separate strand of fringe not less than one inch wide. Pinch the twenty-inch-length

fringe together at the top, wind and tie it with a string (Fig. 242), allowing one end of the string to extend out at the top; wind farther down and tie again to form the head of the tassel four and one-half inches from the extreme top (Fig. 243).

These large tassels tied to picture-hooks by eight or twelve inch lengths of string wound with gay paper and attached to the picture-moulding at the end of each line of flags make a fine finish and form a decoration for the walls.

Let your tables be of different sizes, and cover them with white cotton sheets folded in such a way that the sheet will fall within one inch of the floor at the front and at the two sides.

Decorate the white covering in various ways, making the tables gay with inexpensive colored cambric, or crimped tissue paper. The plain tissue paper will not be strong enough to use for this purpose.

The first covering of white gives value to the colors, causing them to appear even more brilliant than they are in reality, and it also renders it possible to use much less colored material than would otherwise be required, in this way lessening the outlay for decorations. But in order not to tear the muslin sheets while fastening on the decorations, paste must be used in place of tacks or pins.

Make the colored material into wide strips cut into points or fanciful designs and paste the strips at their upper edges along the top of front and sides of the white covered tables, allowing the lower edge to hang entirely free, except where pendant portions are inclined to stand out; these may be fastened in place with a little paste.

Cut some of the strips about fourteen inches wide; others wider, a few narrower; and make each strip long enough to reach around the front and two sides of one table. Lay a brilliant red

strip eighteen inches wide down on a flat surface and fold cross-wise through the centre; fold again and again until the piece

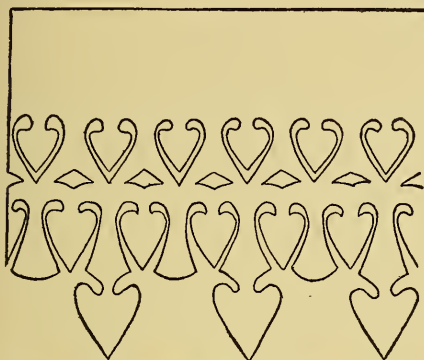

Fig. 245.—Unfolded red paper ready for decorating fair booth.



Fig. 244.—Red paper folded for cutting design.

is of the desired width, about two and one-half inches; then cut according to dotted lines (Fig. 244). Open out and cut off every other lower ornament and you will have Fig. 245. Attached to a table this decoration gives the effect seen in the first illustration.



Fig. 246.—Folded paper for green decoration.

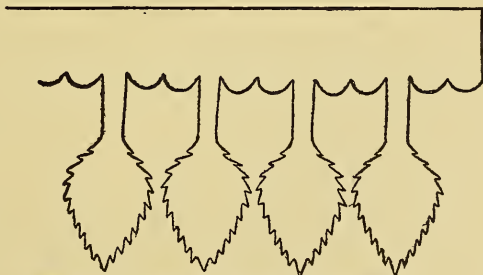

Fig. 247.—Green decoration cut and opened.

Fold and cut a green strip fourteen inches wide like Fig. 246. Open and it will be Fig. 247. Another design of orange color is given in Fig. 248 and Fig. 249.

You can devise many other decorative designs fully as attractive at these, and it is well to experiment with pieces of old newspaper, cutting them into various designs until you find just what you think will make good patterns. In this way your



Fig. 248.—Orange design ready to cut.

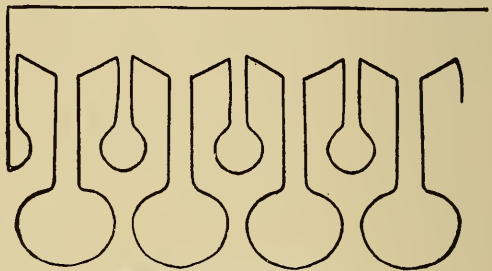

Fig. 249.—Orange design open.

originality is brought out and in a measure your artistic sense developed.

Select a cheery, happy girl for

#### Postmaster

—one who cannot help giving a bright smile with every letter, and try to induce her to make some pleasant appropriate remark when handing out the mail, as this will add much to the enjoyment of the occasion.

More important though than anything else will be the large, the small, the useful, the beautiful and the odd articles for sale made by the girls and boys. There should be a lot of original valentines, May baskets, Easter-egg novelties, paper fireworks,



Hallowe'en games, funny and instructive toys, tiny log cabins, scenes from Japan, Russia, the Philippines, and many other interesting things, not forgetting the Punch and Judy shows, the circus, the seven wonders of the world, and the home-made rugs, candles and candlesticks.

The post-office entails little or no extra expense and money taken in for letters will be almost clear gain. Expense incurred by the entire fair need be but slight and all the proceeds might be devoted to some charitable purpose.

One of the best of objects for the money obtained by your fair is the "Fresh Air Fund," which helps the poor little suffering city children to a breath of pure fresh air and saves the lives of many frail girls and boys. Think how glad you can make some of these young people; then, of all the enjoyment your own companions will have in getting up the fair, and how proud and happy your parents and teachers will feel when they see the result of your work. If a "Fresh Air Fund" does not exist in your locality there are other methods of using your profits to good ends. Really there is no telling how much good your fair may accomplish in many ways.

## CHAPTER XVII

### CAMPING OUT IN YOUR BACK YARD



WHO is ready to go out on a camping expedition to Make-Believe Land?

It is a wild land, full of wild creatures if you choose to believe in them. Cats you will probably meet on the trail, and they are wild ones if you will. Wolves, too, may prowl around, for what else are Tramp and Nipper, your own dearly loved dogs, but descendants of the wild wolf. There will be plenty of sailing, fishing and outdoor sports. Guides can be secured at headquarters and you will not have to travel far, for the camping ground is your own back yard.

You must have your

#### Camping Outfit,

as all campers do, and it is the proper thing to think, plan and talk much about this same outfit. As the trip is to be made overland and you will have no camping wagon, use bags for carrying the various articles needed in camp. Old flour bags are just the thing. Into these you can put all your things except perhaps the camp kettle. The camping party should be supplied with a tent, a hatchet, a camp kettle, coffee pot, tin plates and cups, old knives, fork and spoons, a tin pail and dipper and a tin wash-basin; all these, as well as provisions must be taken on the journey in true campers' fashion, for there should



Camping in Make-believe Land.



be no running back from Make-Believe Land to get forgotten articles. Shawls and blankets to spread on the ground if it seem too damp will be a welcome addition to the outfit, and the party should be provided with sharp pocket knives for whittling stakes and for other needs.

Select the site of your camp and pitch your tent with reference to the clothes line, for the line is to support the tent and act as a ridge pole.

### Make the Tent

of two muslin sheets sewed together along two of the edges, one edge on each sheet, which run from the wide hem at the head to the narrow hem at the foot of the sheet. Tie a tape on each



Fig. 250.—Tie the corners of the sheet with tape.

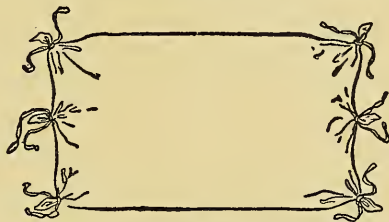

Fig. 251.—The sheet is ready to put up for the tent.

of the four corners (Fig. 250) and tie a tape at the centre of the ends of the tent sheet-covering. This will give three tapes on each side of the tent—six tapes in all (Fig. 251).

Make six wooden pegs resembling Fig. 252. You can have them either round, square, three-cornered or irregular; the only essentials are that the pegs be strong and large enough to hold the tent securely. Have a notch cut near the top for the tape and a point whittled at the bottom that the peg may be easily driven into the ground.



Fig. 252.—This is the wooden tent peg.

Look about carefully and decide exactly where you want the tent placed on the clothesline; then hang the crosswise centre of the covering evenly over the line. Hold the top ridge centre in place with clothespins while you stretch one side out away from the clothesline, and peg it to the ground by tying the tapes around the pegs and pushing the pegs slantingly into the ground, with the peg head running from and the point directed

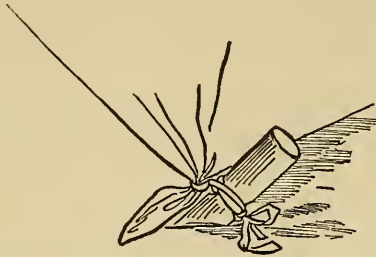

Fig. 253.—This is the way to peg your tent to the ground.

toward the tent (Fig. 253). Remove the clothespins and peg down the other side of the tent in the same way.

Find the best place near the tent for

### A Table,

and make the table in true woodsman fashion. Take four strong forked sticks, sharpened on the lower end, and drive two of them into the ground in a straight line about one foot or more apart, and the remaining two in a line with, and two feet from the first sticks (Fig. 254). Have the sticks stand above the ground about two feet, or the height you want the table, and keep the crotch, or angle where the two forks separate, on all the sticks at an equal height from the ground. Lay a stick across each pair of

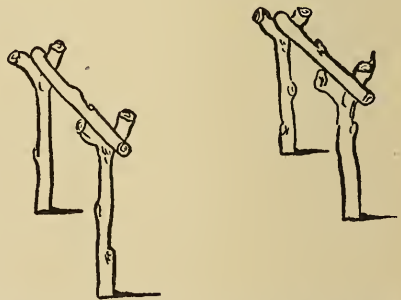

Fig. 254.—The sticks are laid across the table legs ready for the board.

forked sticks. Get a piece of board, rest one end on each of the supports you have just made, and you will have a rustic table,

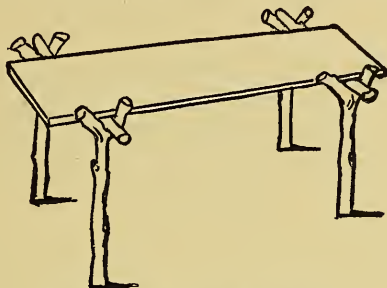

Fig. 255.—Your little camp-table.

strong and suitable for any camp (Fig. 255). Use wooden boxes for seats. Select one box for your

### Safe or Cupboard

in which to keep supplies and camping utensils. Fit one or two shelves, made from a side of another wooden box, in the cup-

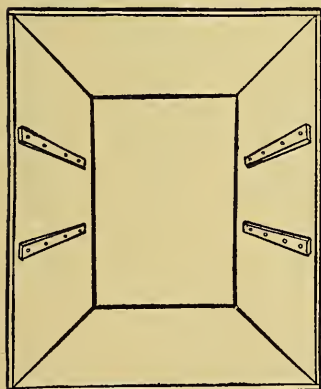

Fig. 256.—Nail the cleats inside the box for the shelves.

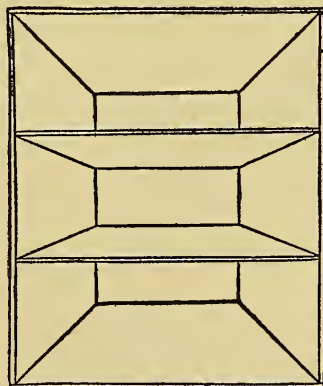

Fig. 257.—This is your camp-cupboard made of a box.

board. Do this by first nailing strips of wood, for cleats, on the inside of each side of the cupboard at equal distances from the bottom (Fig. 256). Slide in the shelves, resting each on two pieces of wood (Fig. 257). Set a lot of lids of tin cans in the cupboard to serve as camping plates, also a few tin spoons, an old table knife, a kitchen fork or two, three tin cups, and a smooth, clean, folded piece of white paper for a table-cloth.

Now for

### The Spring

Ask your mother to let you have a large, clean pail suitable for drinking water. Carry the pail to the opposite side of the yard



Fig. 258.—Sink the pail part way into the ground.

from your tent. There dig a hole large enough to sink the pail down about half its height (Fig. 258). Bank the loose earth up

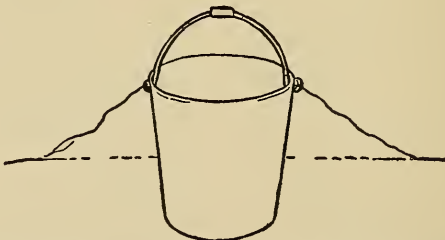

Fig. 259.—Bank the earth up around the pail for the spring.



all around the pail (Fig. 259), and cover the earth with leaves, grass, moss and vines; hiding the pail completely with the green-

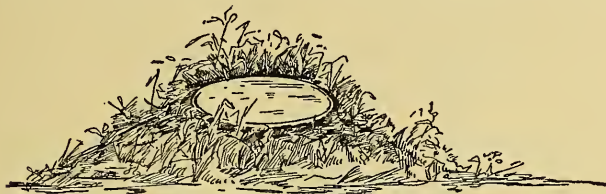

Fig. 260.—Like a country spring in your back yard.

ery; then fill the pail with fresh, cool water, and lo: there is your mountain spring (Fig. 260).

A clean tomato can, free from rust, with the top removed, will make

### A Fine Pail

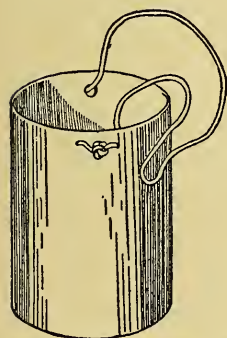

Fig. 261.—The camp-pail is made of a tin can.

for carrying water. You can make a hole in the tin, near the top on each side of the can, by hammering a good-sized wire nail through, and then form a handle to the pail by threading one end of a piece of twine through each hole and tying a large knot on the outside to prevent the string from sliding out of place (Fig. 261). When you need water in the camp, always go to the spring for it, and carry the water in the little tin pail.

It is not necessary to have a real

### Camp Fire,

but you can pretend there is one. Drive two forked sticks in the ground a short distance from each other; lay a stout stick across from one to the other forked stick; then pile up some dry twigs

midway between the stakes. Tie a strong cord on the centre of the cross stick, leaving one end long enough to loop down and under the handle of a pail or kettle and reach up and tie to

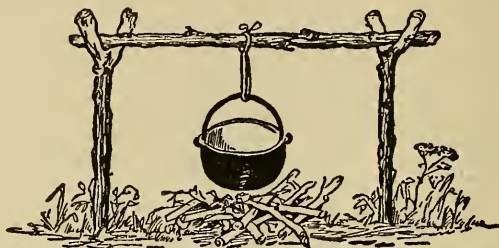

Fig. 262.—You can pretend to cook over the make-believe fire.

the short end of the cord. You can put various things into the camp kettle and pretend to cook them over the make-believe fire (Fig. 262).

Of course you must have a boat, for there are lakes in Make-Believe Land and plenty of fish to be caught, so

### Make a Boat

for your camp. Select a rather long, narrow wooden packing-box (Fig. 263), and on each end tack an extra pointed pasteboard

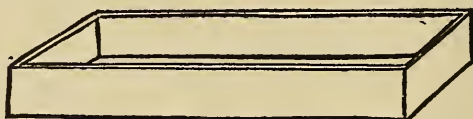

Fig. 263.—A low wooden packing-box for the boat.

end (Fig. 264). To make the pasteboard end you will have to measure the height of the packing-box, and cut from an old

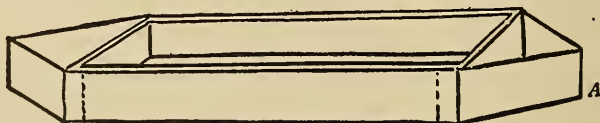

Fig. 264.—The box with its pasteboard ends.

pasteboard box a strip of pasteboard wide enough to fit the height of the wooden box and long enough to allow for tacking on the end of the wooden box and extending far enough out beyond the box to form half, or one side, of the pointed end with two inches over. Score the extra two inches and bend (Fig. 265); the bend A forms the extreme end when the pasteboard point is bent in shape. Cut another strip of pasteboard two inches shorter than the first strip, and sew it on the two-inch bent flap of the first strip (Fig. 266). Score the two ends of the long strip



Fig. 265.—The pasteboard strip with end bent.

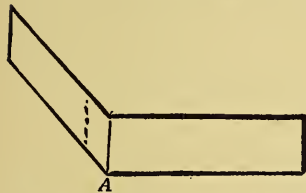

Fig. 266.—The second pasteboard strip is sewed on first strip.

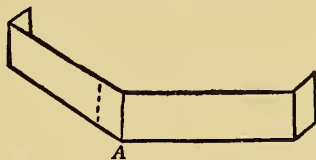

Fig. 267.—The pasteboard is now ready to be tacked on to box making pointed end.

and be careful to score them on the side that will cause the pasteboard to bend outward in the right direction, then bend (Fig. 267).

Tack the pasteboard strip on the end of the wooden box and make another pasteboard point for the other end of the box (Fig. 264). Cover both pasteboard ends with stout paper by gumming the paper over and down on the outside top edge of the pasteboard points.

Make the boat seats of short boards laid across from side to side of the wooden box and nailed in place (Fig. 268). Use broom-sticks for oars, and make believe the boat is off on the water, a long distance from the tent.

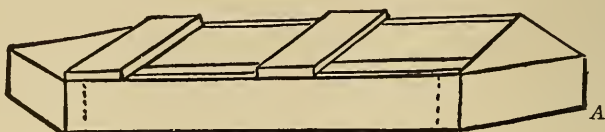

Fig. 268.—With the seats in place it is a boat.

If you want to play that you are

### Out Fishing

in the boat, take any kind of long sticks or walking canes for fishing poles, with common string for line and a bit of paper tied to the end of the string for bait. When you want to turn the

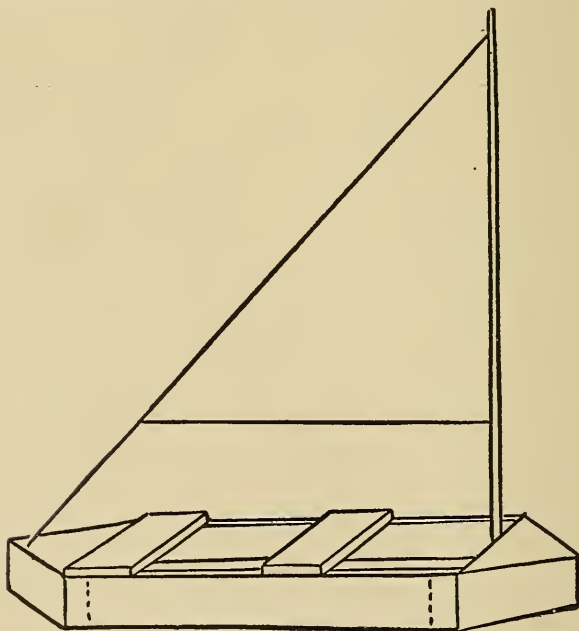

Fig. 269.—The row-boat is turned into a sail-boat.

row-boat into a sail-boat, you can tack a three-cornered piece of white cloth on the end of a pole and rig up a sail (Fig. 269). Cut a hole in the forward centre of the bottom of the boat immediately next to the covered bow, run the pole through the hole down into the earth until it is well planted in the ground and stands straight and steady; then tie a string to the free end of the sail and fasten the string to the boat to keep the sail stretched out, just as if there were truly a good stiff breeze and you were sailing along at a rapid rate with the spray dashing upon, and at times over, the sides of the boat.

If your back yard is large and you need more tents for friends, erect several, one on each stretch of the clothesline. Should the line be fastened to four posts, a tent can be put up on each of the four turns of the clothesline, making a little settlement of tents.



Playing Tether-Ball with the Home-Made Game.

## CHAPTER XVIII

### OUTDOOR FUN WITH HOME-MADE TETHER-BALL



WITH an outlay of a few cents you can make this entire tether-ball game and make it well. The common hollow rubber ball should be two and a half inches in diameter—about the size of a tennis ball. You will not need any money for the two rackets, which are cut from old boxes or shingles.

#### The Pole

may be a stationary clothesline post, a small, unused flagstaff, an extra long clothesline pole, a long curtain pole, or a very long, straight bean pole, and for smaller children the handle of an old long-handled broom will answer.

Use strong, soft twine to make

#### The Cover for Your Ball

Cut twelve pieces, each twenty-four inches in length; place all the lengths straight and evenly together; then tie a string around the entire bunch, an inch and one-half from the centre (Fig. 270). In this figure and several other diagrams the single strands of twine are not drawn in detail, because, should every separate thread be outlined, much confusion might ensue.

After tying the lengths of twine together, separate the longest part into three divisions of four strands each (Fig. 271). Braid



Fig. 270.—Tie all the strands of the string together.

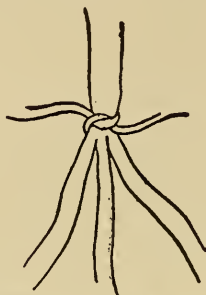

Fig. 271.—Tying the strings for the tether-ball covering.

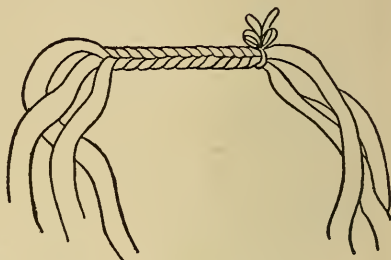

Fig. 272.—The braid for ball loop.

these strands together in one braid, beginning close to the string tied around the bunch; continue braiding firmly and tightly for the distance of two and a half or three inches (Fig. 272), then untie

and remove the string from around the bunch (Fig. 273); bring the two ends of the braid together, and joining

all the loose strands into three bunches of eight strands each, braid all into one braid (Fig. 274).

When this larger braid is one inch long, with another string tie the loose

ends of it firmly together close up to the

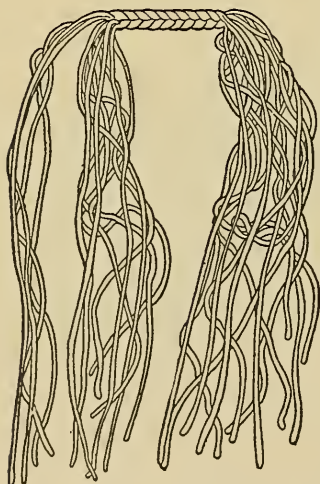

Fig. 273.—Untie and remove the string.



Fig. 274.—Braid into one braid.



braided. You will then have a braided ring on a braided stem. Wind the stem with an extra string; then tie a hard knot and cut away the ends of the string (Fig. 275).

Divide the loose strands into bunches of three strands each, making eight bunches (Fig. 275). Pin the stem down to something stationary and firm; then take three strands, or one bunch, in each hand, and pass the first finger of your left hand between the two bunches; hold it there while

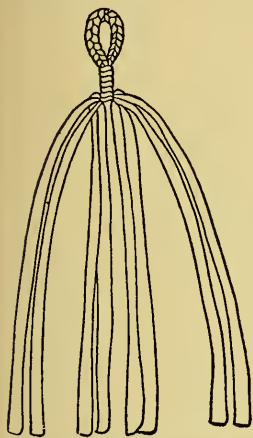

Fig. 275.—The strands are ready for netting the ball cover.



Fig. 276.—First step in tying string covering for the ball.

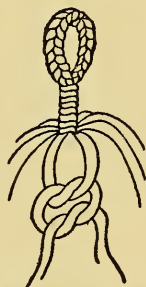

Fig. 277.—Tie the knots in this way.

you carry the bunch in your right hand across the bunch in your left hand; this forms a loop. Do not take your finger out of the loop until the entire double knot is made. Bring the bunch from your right hand under and through the loop formed by the crossing of the bunches; this will give Fig. 276. Pull the strings until the tie is a short distance from the stem; then tie the same strands again to form a firm knot. Fig. 277 shows the method.

Tie together two more bunches, and two more, until all the bunches have been used and you have made four knots (Fig. 278).

Fit the network over your ball (Fig. 279), allowing the covering to remain on the ball while you tie the bunches of strands into another row of four knots below the first row. Look at Fig. 278. The bunches are all numbered, showing

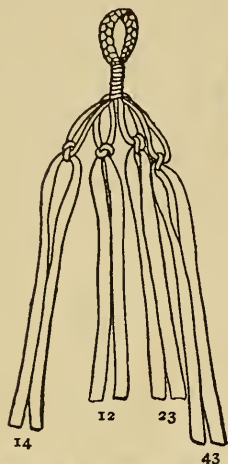

Fig. 278. — First row of knots in ball cover.

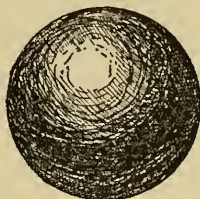

Fig. 279.—The uncovered tether-ball.

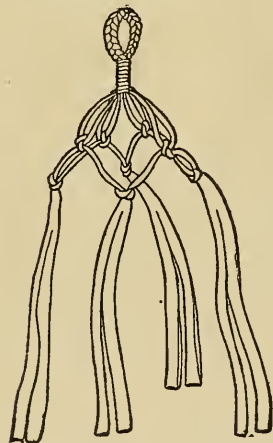

Fig. 280.—The second row of knots in ball covering.

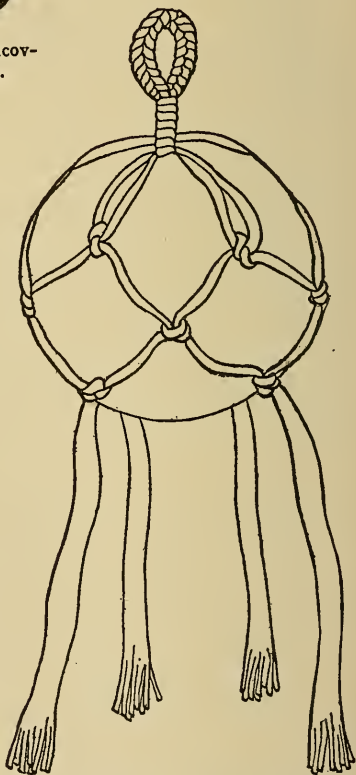

Fig. 281.—Covering of tether-ball almost complete.

how they are to be united. Corresponding numbers must be tied together: 1 with 1, 2 with 2, and so on. The result will be like Fig. 280.

Keep the ball in the net and make another lower row of knots, which will give you Fig. 281.

Now turn the ball over and tie two opposite bunches of strands up tight and firm against the bottom of the ball (Fig. 282 A).

Bring together the remaining two bunches, B and C, and tie them over the knot A. Again tie in a hard, firm knot; then bind all the strands together by winding with a separate piece of string. Fasten securely.

It is necessary for the ball to be covered, so that it may have a strong yet harmless ring at the top, for no metal may be used on the ball.

Before erecting the pole you must mark out

### A Court on the Grounds

Drive a stick in the earth where you want your pole to stand. On this stick tie a piece of string close to the ground; then sharpen the end of another short stick and tie the other end of the string on the second stick near its top; let the string measure two and one-half feet from one stick to the other stick. Pressing the point of the second stick slantingly against the earth, run it around and around in a

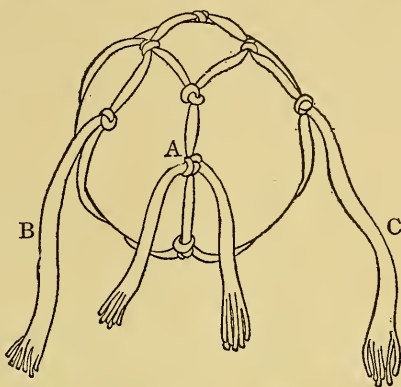

Fig. 282.—Tying final knot on the bottom of the ball.



Fig. 283.—Mark out the tether-ball court in this way.

circle until a circular line is distinctly marked (Fig. 283), then you can pull out the stake and dig a hole where it stood at the

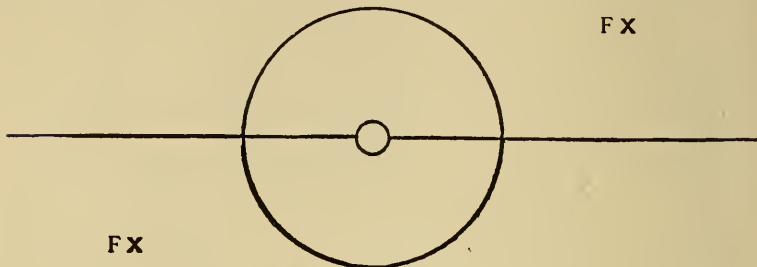

Fig. 284.—The tether-ball court.



Fig. 285.—Cut a notch near the top of the pole.

centre, and plant your pole. Mark a straight line across the centre of the circle and extend this straight line beyond the edge of the circle six feet on each side. On opposite sides of each of the straight lines running out from the circle mark a cross about two and one-half feet from the circle and two and one-half feet from the line, F and F (Fig. 284). The cross designates the spot where the player on either side must stand to serve the ball when the

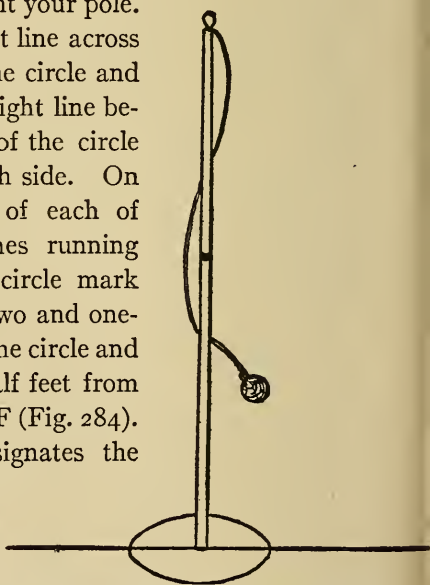

Fig. 286.—The tether pole is erected and ready for the game.

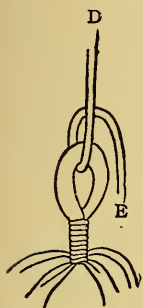

Fig. 287.—This is the first step in tying the ball to the pole-string.

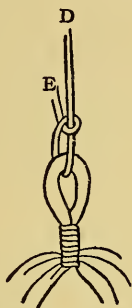

Fig. 288.—Second step in tying ball to pole-string.

up above the surface of the ground, vertically, to the height of about three feet above your head. Cut a notch near the top of the pole before erecting it (Fig. 285). Tie one end of a long string fast around the notch. The string must be well waxed, twisted and doubled and waxed again, and it must reach within two feet of the ground. Tie the ball on the loose end of the string and erect your pole so firmly that it will not even tremble when you bat the attached ball ever so vigorously (Fig. 286). Fig. 287 gives the first step in tying the ball on the pole string. D is the end attached to the pole, E is the loose end. Pass E under D, then around back again over D and through the loop (Fig. 288);

game begins. The crosses are called service crosses.

The length of the tether pole you are to use depends upon your height and that of your young friends. Make the pole long enough to allow being planted sufficiently deep to be firm and steady and extend

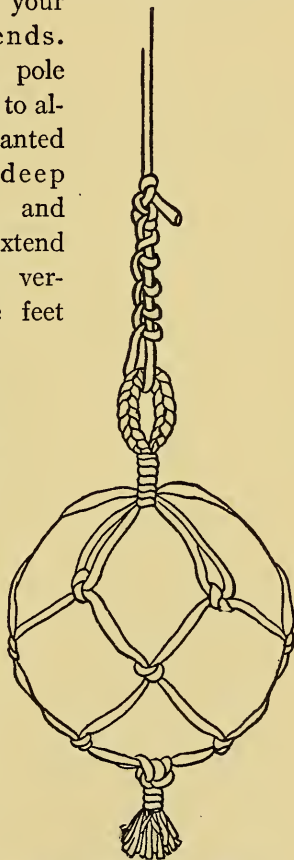

Fig. 289.—The tether ready to play.

repeat this stitch over and over, drawing the string very tight each time. Finish by tying the E end of the string on the D end in several knots. Examine Fig. 289. It will give you the process of tying, but the knots are drawn loose that you may see how each is made. Paint a red ring around the pole just above the height of your head. Make

### A Pattern for the Rackets

of a piece of paper twelve inches long and five and one-half inches wide; fold the paper lengthwise through the centre and cut ac-



Fig. 290.—Paper pattern for the racket.

according to curved line in Fig. 290. Open the pattern and lay it over a shingle, the handle at the thickest part; draw a pencil line around it and carefully whittle out the racket. Smooth down the rough edges with sandpaper (Fig. 291). Make a second racket in the same way. Now let us thoroughly understand the meaning of the divisions of the court before



Fig. 291.—The finished racket looks like this.

attempting the game. Inside the ground circle no one shall go, for it is not allowable at any time during the game to step on, or within, or reach over the circle line on the ground surrounding the tether pole. The straight line is used to divide the ground into two courts, one on each side of the line, making a separate court for each player.

The cross in each court is intended to mark the spot where

a player must stand to "serve" or strike the ball when the game first begins. The player must stand on the cross of the chosen court while serving; at other times during the game she may go any place within her court, but she must stay in her own court on her own side of the line.

### **The Object of the Game**

is for each player to strike the ball on the end of the string in such a way as to cause the string with ball attached to wind completely around the pole above the red band.

The game is intended for two players, and it begins by each one, in turn, tossing a small stone or piece of wood as near as possible to the tether pole while standing at a spot, previously marked, ten feet from the pole. The girl landing a stone nearest the pole has first turn and choice of courts; the other player must go in the court on the opposite side and beyond the circle.

The server holds the ball in her hand and, striking it with her racket, endeavors to send the ball winding around the pole, but as the ball approaches the other player or opponent, the opponent tries to stop the progress of the ball with her racket and send the ball back to wind around the pole in the opposite direction. As the ball returns toward the first player, a second time she endeavors to strike it and wind the string her way around the pole. In this manner the ball is kept going back and forth between the two players until one player succeeds in winding the entire string and ball above the red band; this wins the game, and the girl winning the greatest number of games out of eleven wins the set.

While playing the game the ball may be struck but once at a time, no player being allowed to have two or more trials during one turn.

The turns shall alternate between the two players.

If a player fails to send the ball into her opponent's court on its way around the pole, the failure is called a fault, and the player making the fault loses her turn. The lost turn goes to the opponent, who then stands on the cross in her own court and has a free strike at the ball.

If a player strikes the ball more than once during one turn, she is guilty of a fault, and loses her next turn. If a player oversteps the boundary of her own court in any way, she is guilty of a fault and loses a turn. When the string winds around the handle of the racket, or winds about the tether pole below the red band, the player so winding the string commits a fault and loses a turn.

All faults give the opponent a free hit from the cross on her own court.

When grown-up girls and boys play tether-ball, the pole must stand nine feet high when erected. The red band on the pole must be six feet above the ground. The circle on the ground around the pole must be three feet in diameter. The straight line dividing the courts must extend ten feet outward from each side of the pole, making the entire length twenty feet. The ball must hang, when at rest, two and one-half feet from the ground.

This game may be played by sides, of equal numbers.



PART II  
MINIATURE SEVEN WONDERS  
OF THE WORLD



## CHAPTER XIX

### THE PYRAMIDS OF EGYPT



If you could have seen a certain little boy who lived so long ago that it would make you dizzy to try to think back to the time when he ran about playing and learning many things, you would have thought him a queer looking little chap. He was not clothed like boys of our day, and his skin was almost a copper color, resembling somewhat that of the American Indian. His name was a very odd one, spelled C-h-e-o-p-s and pronounced Ke-ops—possibly his comrades nicknamed him “Key” when they played together on the sand. He had another name, Khufu, and it is hard to tell which the boy liked better.

#### Cheops's Home

was in Egypt, where there are more crocodiles than you can count, and doubtless the little brown fellow, at a safe distance, enjoyed watching the sleepy creatures while he vaguely wondered why crocodiles always crawled up on the banks to lie so long and still in the sun. There were many other strange animals and queer Egyptian things—unlike any you have ever seen—that interested and delighted the child. When Khufu grew to be a man he was

### **A Great Monarch,**

an Egyptian King, and instead of watching crocodiles busied himself watching and ruling a nation. The King did not bother greatly about the house he lived in, but spent much energy and many years in building an enormous pyramid, the largest ever erected at any time. When you grow older you may possibly take a trip to Egypt and see this

### **Wonderful Structure,**

built 900 B.C. It is made of huge stones, most of them thirty feet long, five feet high and four or five feet wide. How do you suppose men ever managed to lift such monstrous blocks to build the pyramid? Well, they were obliged to labor very hard, for it took two hundred layers of stones for the pile, and all the work was done with the utmost care and precision.

You must also use care and precision in building your Egyptian pyramids. Have them exact, and in place of the heavy stone blocks use

### **Coarse Sandpaper**

If possible, get it of a tawny yellow hue, that the miniature pyramids may be the same color as the originals, now that the outside casings of the latter are off. King Cheops had an army of one hundred thousand men laboring constantly during twenty long years to pile up his stones. You can make your Khufu Pyramid in twenty minutes and need employ only ten fingers instead of one hundred thousand men.

Cut one side of

### **The Pyramid**

from sandpaper (Fig. 292); if the paper is not stiff enough, paste it on a piece of cardboard; an old box-lid will do. Make

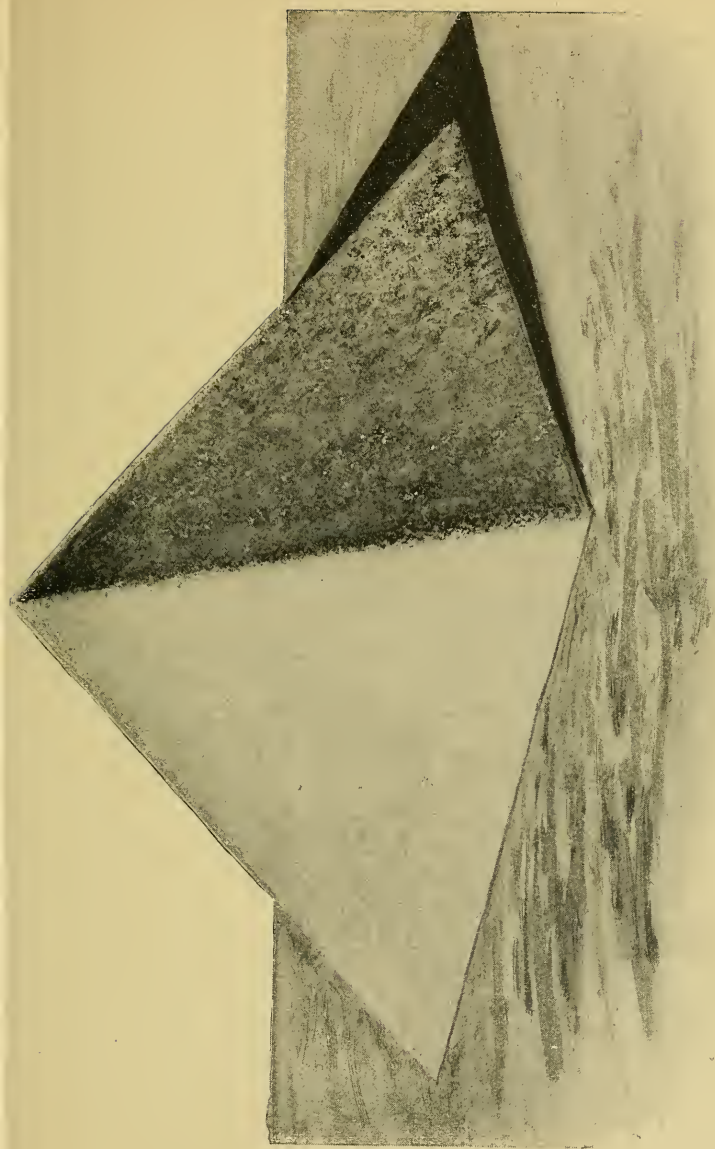

The Great Egyptian Pyramid Cheops, Made of Sandpaper.



two more sides like the first and gum narrow strips of muslin along the right side edge of each (Fig. 293). The dotted line

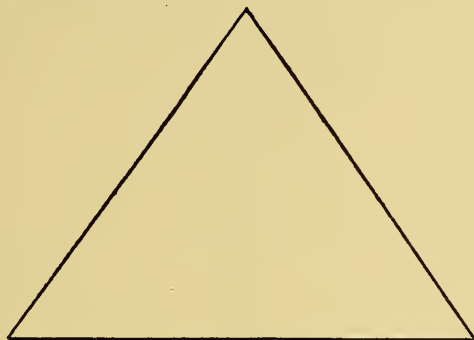

Fig. 292.—Cut one side of the pyramid of sandpaper.

shows the edge of the pasteboard underneath the cloth. Join all the parts together by means of these strips (Fig. 294). When

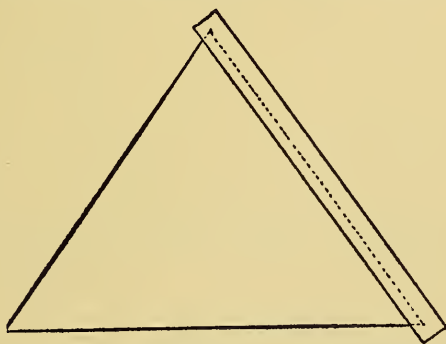

Fig. 293.—Gum narrow strips of muslin along the right side edge.

making the fourth side, extend it out into the projection (T, Fig. 294) and cut a corresponding slit in the first side (U, Fig. 294). Place the pyramid down flat on a level surface under a weight

to dry. When ready remove it and cut off the ends of the strips (S, V, O, Fig. 294); then bend the toy into shape by bringing the first and fourth sections together and sliding T into U (Fig.

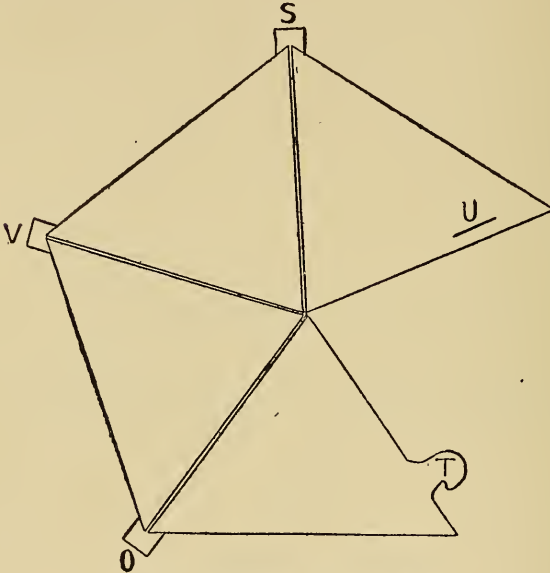

Fig. 294.—Join all the parts together.

294). The pyramid must stand erect and firm as in Fig. 295. Remember that the four sides of the real pyramid are built upon

### A Perfect Square,

and the base lines of yours should also form a true square. If you can get some tough paper which will fold together in a flat crease without breaking, you may make the pyramid of one piece instead of four, by cutting it the shape of Fig. 296 and bending



it evenly along the dotted lines to form the four slanting sides. The loose ends must be fastened together by means of extension and slit. If you have no regular sandpaper make some. Give the paper a thin wash of glue, and before it dries sprinkle it evenly with sand. An old kitchen pepper-box filled with sand

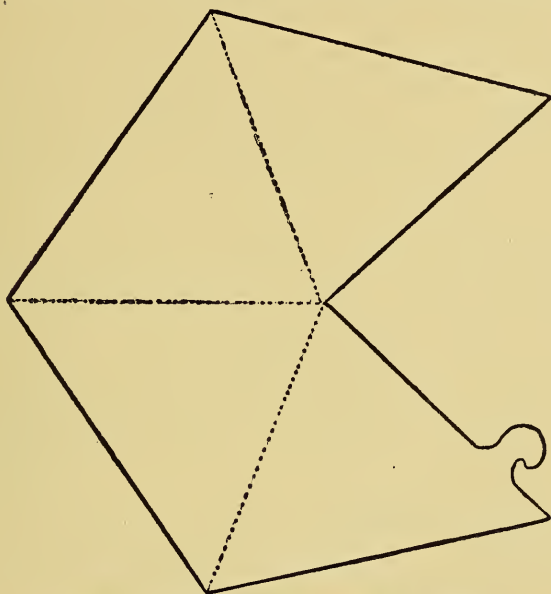

Fig. 296.—You may make the pyramid in one piece.

will make a fine sprinkler. If you cannot get the pepper-box, take a small empty baking-powder can and punch tiny holes in the cover by hammering a fine wire nail through the tin in many places; use it as a sprinkler. You must prepare the paper and have it evenly sanded before cutting out the design.

In Egypt there are three famous structures in addition to the Sphinx: the great pyramid, the middle-sized pyramid and

the little pyramid—like the big bear, the middle-sized bear and the little wee bear in the story book. Each

### **Pile of Stones**

was set up by a different king, and each one is named for the monarch who built it. The largest is called for Cheops; the second is named Chephren (pronounced Kefren) and the smallest has the longest name Mycerinus (pronounced Me-ker-in-us). Make the colossal Cheops as large as the dimensions of your paper will admit. The original is like a mountain, measuring 746 feet each side of the square foundation and reaching up 450 feet and nine inches in height.

King Chephren did not build his stones quite as high; he was satisfied with a base, each side of which is 690 feet and nine inches and a height of 447 feet and six inches. The last, King Mycerinus, must have grown tired of playing with the stone blocks, for his pyramid is merely a hill 203 feet high, with each side of the foundation 354 feet and six inches, not nearly so tall as Cheops's monument. Build your little pyramid about half as high as the second one.

After making the Egyptian structures, naturally you might think that they could be grouped as you pleased to place them, but these pyramids are

### **Different from Ordinary Toys**

and must always be fixed in certain positions. Stand them in a diagonal row, each one facing exactly E. W. N. S. Fig. 297 gives their correct positions. The first must stand to the northeast of the second, the second to the northeast of the third, and the Sphinx east of the second monument.

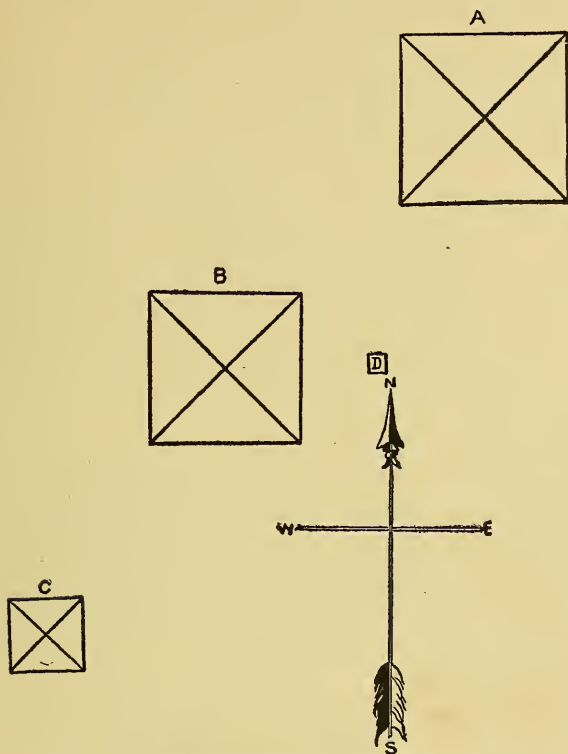

Fig. 297.—Stand the pyramids in a diagonal row.

There, they are finished. Now that we have built the pyramids, let us

### Carve the Wonderful Sphinx

with its body like a crouching lion and its head, like a man's, modelled from that of an ancient Egyptian. The original is an enormous queer creature hewn from stone and made before the pyramids were built; consequently, it is very old. It was on the



Fig. 298.—Cut the Sphinx out like this.

plains more than 4,000 years before the birth of Christ. Little wonder that it now appears worn and chipped and that, like your small sister's doll its nose is broken off.

Begin carving the Sphinx by cutting a larger size from Fig. 298 of stiff sand-paper. Mark the head with ink as nearly as possible like Fig. 299. Should you fail in this, find a print of the head in some old paper or magazine, cut it out and paste it on Fig. 298. Bend the design across the dotted line, and the Sphinx will be ready to crouch close down on your sandy plain.

There is no need of carving the body, because that of the real Sphinx is entirely covered with sand, with only the head above ground, and we want ours to look like the original.

In parts of Egypt the wind sweeps the sand in great masses against and over all objects, so the people had their

#### **Buildings Made with Slanting Sides**

that the sand might slip off when it struck them. Try pouring some sand on your pyramids and you will understand the

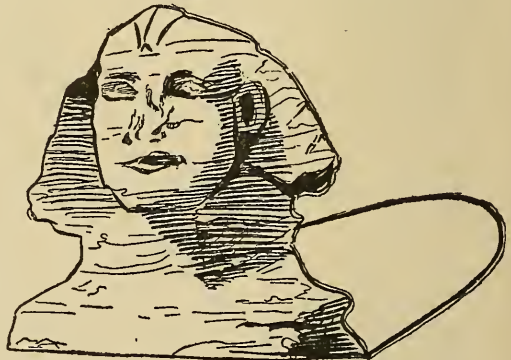

Fig. 299.—The head of the Sphinx should look like this.

reason of the peculiar style of architecture. The land in Egypt on which the Sphinx and pyramids stand is the plain of Gizeh; consequently, you must give that name to the place where you set up your structures. The



Fig. 300.—Cut this from green paper.



Fig. 301.—The tall date palm.

### Tall Date Palm

is a beautiful tree. The leaves are glossy and spread out in a graceful crown; its stem is marked with old leaf scars, giving it a very different appearance from the bark of our native trees.

Cut Fig. 300 from light-weight green paper, and mark it as Fig. 301; then cut Fig. 302 of very stiff pasteboard. Paste Fig. 300 on the top over the letter P; next bend the stem where it joins the base (Fig. 302) and plant the tree almost any place on your plain of Gizeh.

Several date palms, either grouped or scattered, would look well and tend to relieve the severity



Fig. 302.—Bend the stem where it joins the base.

of the landscape. A thin layer of sand sprinkled over the plain, the stand of the Sphinx and the paper roots or stands of the trees



Fig. 303.—Enlarge this camel.



Fig. 304.—Make the saddle of writing paper.

will give the place a realistic appearance, and the scene will then be ready for the camels and Arabs. You may own

#### As Many Camels as You Desire;

all you have to do is to use the old Egyptian method of squares, as explained in Chapter XIV, and it will enlarge the camel in

Fig. 303; then cut out the figure, lay it down flat on cardboard and run a lead pencil around its edge. Cut out this second animal

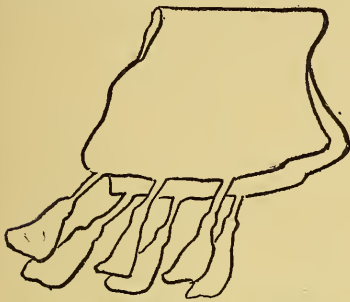

Fig. 305.—Fold the saddle in this way.

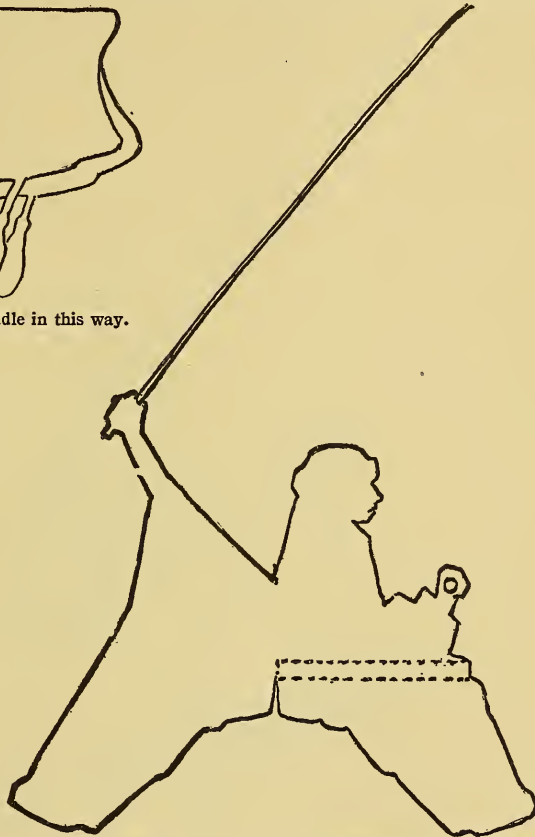

Fig. 306.—Cut out the Arab like this.

and repeat the outline as often as you want camels. You will then have fine camels which will stand firm on four feet and be strong enough to carry burdens.

**Make the Saddle**

of writing paper (Fig. 304). Paint or mark it as in Fig. 308, fold it like Fig. 305 and fit it on the camel's back.

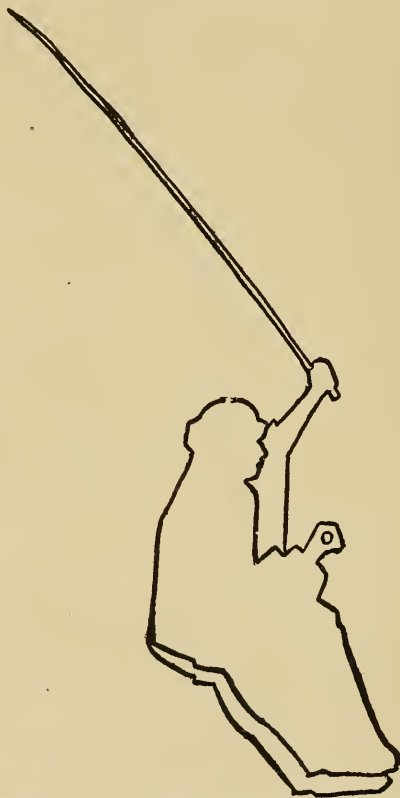

Fig. 307.—Fold together at back in this way.

Cut out the Arab (Fig. 306), being sure to make the short slit in the back of the drapery so that the man will sit well on the



saddle. Along the dotted lines place a strip of paste and fold the figure at the back, pasting the two sides together at the centre



Fig. 308.—Arab on the camel.

(Fig. 307). When dry mark as in Fig. 308 and mount him on the animal. As a harness tie a string on the camel's head, orna-



Fig. 309.—Fasten a harness on the camel's head.

ment it with tiny tassels (Fig. 309) and give the end of the string to the Arab, threading the string through the hole in his right hand (Fig. 308).

The trees, animals and men must be placed some distance in front of the pyramids, that the latter may seem to be a long way off; otherwise, all your objects will be out of proportion, because when a live camel stands close up to the Grand Pyramid it looks very small. Have several

#### Camels with Men Riding

them, some free from harness and rider, others held with the halter by Bedouins seated on paper rocks, which you can make by bending a piece of cardboard the right height.

All the objects given can be enlarged to any desired size by the system of squares shown in Chapter 14, and the entire Egyptian scene may be taken up, each piece folded flat and placed in a large envelope when not in use.

## CHAPTER XX

### THE COLOSSUS OF RHODES



RETEND this is not the twentieth century, but 288 B.C., and that, with many other young people, your home is hundreds of miles away on a little island in the Mediterranean Sea called Rhodes. Here the weather is sunshiny and bright, and children do not have to remain indoors because of the rain, for on this delightful island the sun comes forth in all its glory nearly

every day during the year. The people think so much of the sun that they erect statues to it, which they call "sun gods"; they even have the head of a sun god on one side of their coins, and on the other side they print a rose, for the citizens of Rhodes are almost as fond of that flower as they are of the sun. Such quantities of roses grow on the island that all girls can have as many as they wish.

Now, we will play that

#### Your Name is Chares

of Lindus, that you are a great sculptor and can model all sorts of wonderful and beautiful objects, and that the city of Rhodes has commissioned you to make a gigantic bronze statue of Apollo,

their sun god. So you must pretend that you have built two small islands at the entrance to the port of Rhodes, and that on each island you have erected immense stone pedestals fifty feet high, so that your Colossus need not be obliged to stand in the water. The statue must be made to span the harbor with "legs wide apart," as Napoleon stands in the pictures of history.

Apollo must be very large, about one hundred and eleven feet high, in order that every ship entering the harbor may pass between the legs of this

### Towering Colossus

as a tribute to the god; and when sailors approach the statue and pass beneath it they will marvel at the beautiful figure of polished metal and carry news of it all over the world.

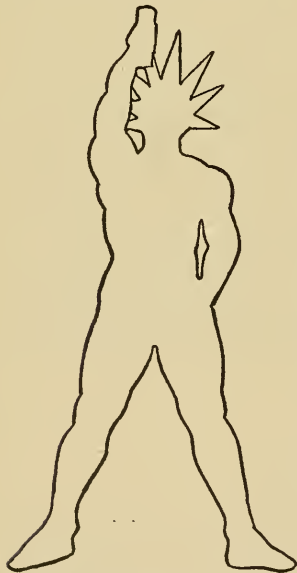

Fig. 310.—Enlarge this pattern very carefully.

Make the Colossus of bronze filled in with stone. Use stiff fine lawn or fine batiste as the outer bronze covering of the statue; let the cloth be perfectly smooth, without a wrinkle. Take raw cotton batting for the stone filling. Enlarge very carefully on stiff, smooth paper the pattern (Fig. 310); make it measure nine and one-fourth inches from the tip-top line to the bottom line; then cut it out and lay the paper pattern down flat over a double fold of the cloth. With a soft lead pencil run a line on the cloth entirely around the figure; be particular about having all the curves of

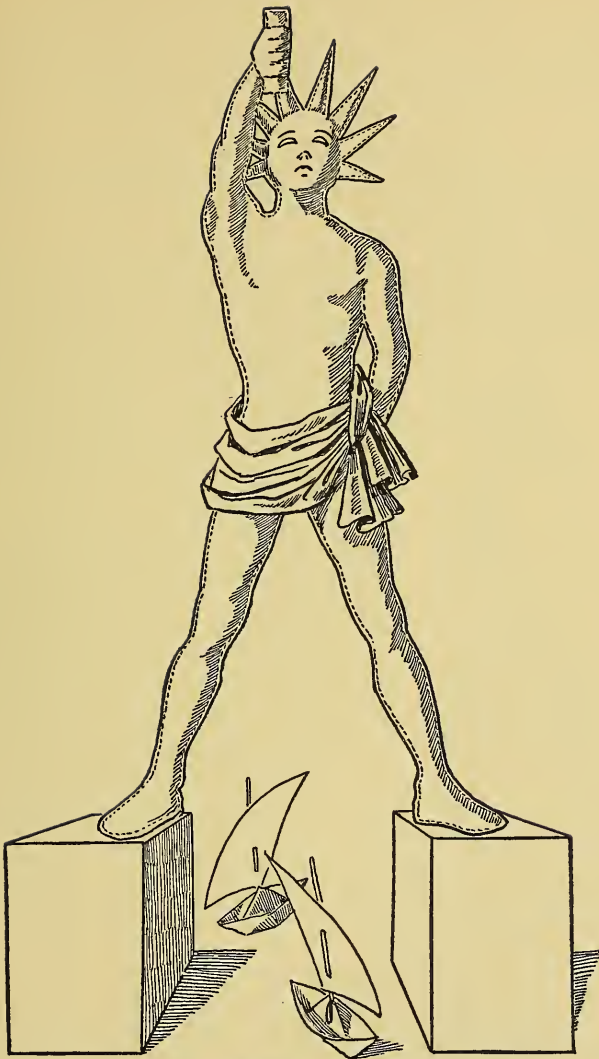

Fig. 313.—Your Colossus of Rhodes will look like this.

the figure correct. Baste the two layers of cloth together and machine-stitch them around the outside edge of the pencil outline.

### Do not Sew the Lines Straight

where they should curve; remember this and devote the best of your talents to the work.

Leave a half-inch opening at the shoulder of the upraised arm A (Fig. 311). Pull off a bit of the soft, raw cotton and force

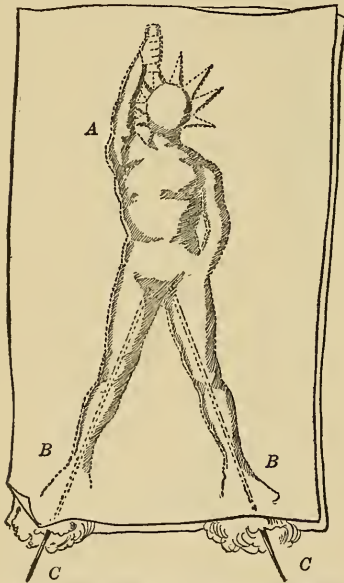

Fig. 311.—This is the way to build the Colossus.

it in at the opening A (Fig. 311) between the front and back of the figure. With a smooth, slender, dull-pointed stick push the cotton well up into one of the points surrounding the head, which represent the rays of the sun. When you have the cotton in the tip of the point, pack in another piece and continue to stuff the point with cotton until it is filled out firmly. Stuff all the points and the head in the same way; then fill the opposite shoulder and upper part of the arm which is held down at the side, and next the uplifted hand and arm, and the body.

### Begin at the Sole

of the left foot and stuff the lower half of the partially filled hanging arm, then the lower part of the body and the entire length of the leg, and fill in the other leg. Before stuffing the feet take

two strong, stiff hat-pins and break off the heads. If you bend the ends in removing the heads, hammer them out straight again; the pins must be perfectly straight. Very carefully work a pin, broken end first, up each leg well into the body. The dotted lines along the legs in Fig. 311 represent the pins placed inside; the points of the pins extend not less than an inch and a half below the feet B, B (Fig. 311). C, C (Fig. 311) shows the raw cotton, which has not yet been packed into the feet. Lift the figure by the two pin points, and if it is firm and stiff finish stuffing the feet; if it bends when held by the pin points, carefully twist out the pins and insert them again, adjusting them until they keep the figure stiffly upright when held by the points.

Sew up all the openings and

#### **Cut Out the Statue,**

then slowly punch open the centre of the divisions between the rays around the head and the uplifted arm, with the point of a blade of the scissors. Enlarge each hole by twisting the pointed end of a penholder around and around until the opening is sufficiently large. Turn the Colossus over on the other side and carefully cut away the fringe of cloth that surrounds each opening. In like manner open the space between the body and the arm extending down the side.

When stuffing the figure, use the cotton soft; do not roll it into hard wads, and be careful not to run the end of the stick through the cloth covering and tear it; the same care must be taken when inserting the pins up the legs. With thread and needle stitch an outline between the fingers and around the lower portion of the raised hand. Filling in the figure with cotton will give you an idea of the labor your great-grandmothers expended upon their bedquilts when they stuffed elaborate designs

of grapes and vines on the coverings. Such quilts are now highly valued. Give Apollo an

### All-over Coat of Varnish

When the statue is perfectly dry bronze it with liquid bronze, and if the small openings by the side of the arms seem partially to have closed, twist the end of the pen handle through each one to enlarge the spaces.

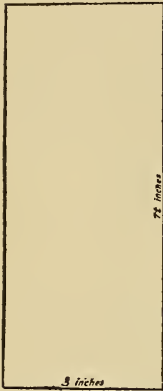

Fig. 312.—Cut a strip of cloth for drapery.

Cut a strip of cloth according to Fig. 312 for drapery. Hold one end against the figure at the side where the arm joins the body and fold the cloth loosely across the front and around the back of the figure, bringing the other end of the drapery forward through the space between the arm and the body. Fasten it in place with a pin (Fig. 313). Bronze the scarf so that no portion of unbronzed cloth is visible; then allow the statue to dry, and with sharp scissors trim off any little ravellings along the edges of the stitching. With pen and ink

### Mark the Features

on the face. The chin being held up foreshortens the face; this means that the position causes the features to look as if they were closer together than they actually are, and that the eyebrows are nearer the top of the head, which makes all the features seem higher than when the chin is held level. Do not forget this while inking the face. Draw rather high on the forehead two curved lines for the eyebrows; under these mark two curved oblongs for the eyes, a curve for the nose, with two elongated dots for nostrils, a larger curve for the mouth and a little one





Making the Colossus of Rhodes

for the lower lip. Practise drawing the face on a piece of paper before attempting to ink it on the bronze head.

Find or make two boxes of heavy cardboard each about two and a half inches high, an inch and a half wide, and two and a half inches deep. Open the boxes and give the outside a thin coating of glue. While the glue is wet sprinkle with sand, and, when dry, replace the covers and the boxes will be two stone pedestals for the statue.

### Erect Apollo

upon the stone foundation by pushing the projecting pin points through the tops of the boxes; work a cork on the end of each pin point, having the cork large enough to rest firmly on the bottom of the box after it is attached to the pin point; then, holding each cork in place, fasten them in turn to the bottom of the box by pushing a common pin up through the bottom of the box into the cork. Fig. 314 shows the inside of the sanded box with the point of the hat-pin firmly planted in the top of the cork, while the cork is held securely to the bottom of the box by means of the pin run into it from the outside of the box. Apollo must stand firm; the statue and foundation boxes should be so securely fastened together as to seem made in one piece.

There, the famous Colossus of Rhodes, one of the renowned Seven Wonders of the World, is com-

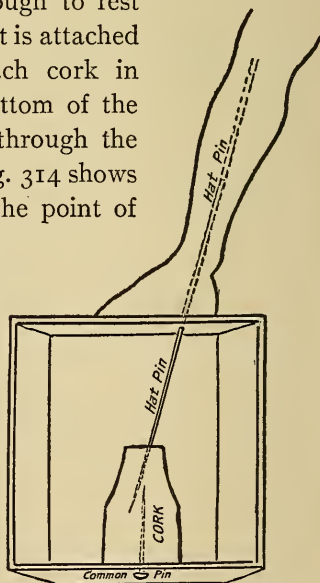

Fig. 314.—Fasten the statue's feet to the boxes in this way.

pleted, and now that you have made the statue you can never forget it. Pretend that Apollo towers in the air at least one hundred and fifty feet when on the pedestals. Of course, such a remarkable piece of sculpture could not be constructed in a moment's time, so make-believe that you, the sculptor, Chares, of Lindus, have been twelve years at work on the wonderful bronze figure. Get a sheet of blue tissue paper to serve as the water, stand Apollo on it, and make two or three

### **Tiny Paper Boats with Masts;**

set them on the water under the bronze statue that the vessels may be sailing beneath the statue into the harbor of Rhodes (Fig. 313).

When you have erected the Colossus on a table and everything is ready, invite the girls and boys in to see the work; tell them all about the statue's being one of the "Seven Wonders of the World" and what fun you had making Apollo, and that you intend to make another of the "Wonders," which you will show to them.

Play that the Colossus has stood guard over the harbor of Rhodes for fifty-six years; then make an earthquake

### **Tumble it Down**

Double up your hand and give a hard knock on the under side of the top of the table, exactly beneath the spot on which Apollo stands. With a little aid of the imagination the noise produced will sound like the rumbling of an earthquake, and the shock will cause the earth, or the top of the table, to tremble and quake violently, and down will fall the Colossus.

Make believe that

### **The Statue is Broken**

in many pieces and that the people of Rhodes allow the fragments to lie scattered on the ground, for you know that after the real Colossus had been thrown down, it remained where it had fallen for many centuries, until the year 656 A.D., when Rhodes was conquered by the Saracens, who sold many of the pieces of the bronze sun god to a Jew of Syria Edessa. This man had nine hundred camels carry the fragments on their backs to Alexandria.

Nearly three centuries after the disaster, Pliny saw the pieces of the Colossus still lying where it fell: "And even as it lies there prostrate," he reports, "it stirs to wonder. Few men can clasp its thumb with their arms; the fingers alone are greater than most statues; vast caverns yawn in its shattered limbs; within one sees blocks of stone by whose weight the builder established it."

### **The Colossus**

cost about \$500,000, which was obtained from the sale of the engines of war presented to the Rhodians by a man named Demetrios Poliorketes, after they had made him give up the siege of their city, 303 B.C.

There were several thousand statues in Rhodes but none so large as the Colossus, which is said to have weighed 720,900 pounds. The famous Laocoön and the Farnese Bull were both modelled in Rhodes. In Roman time Rhodes was thought the fairest city in the world and is described by historians as superior to all other cities of its era, for the beauty and convenience of its ports, streets, walls and public edifices, all of which were profusely adorned with works of art. Among the students in its university were Brutus, Cassius, Cæsar and Cicero, and the first Greek grammar, the one which became the model of Greek and

---

Latin grammars, was written in this city, so you find that Rhodes has played a very important part in the world. But the island of Rhodes is no more a powerful state; it is now a possession of Turkey, and is ruled by a pasha, who holds office for life, governing also the adjoining islands belonging to Turkey, and collects the revenues. We will have interesting news from time to time from this same island, for one of the newspapers has stated that a Danish scientific expedition will go to discover all that remains of the Colossus of Rhodes. You must be on the lookout, therefore, to know how much they find of the statue and how the pieces look; then you will wish to compare your Colossus of Rhodes with the facts stated and any pictures which may be published on the subject to see how closely your Apollo resembles the original "Wonder" of the world.

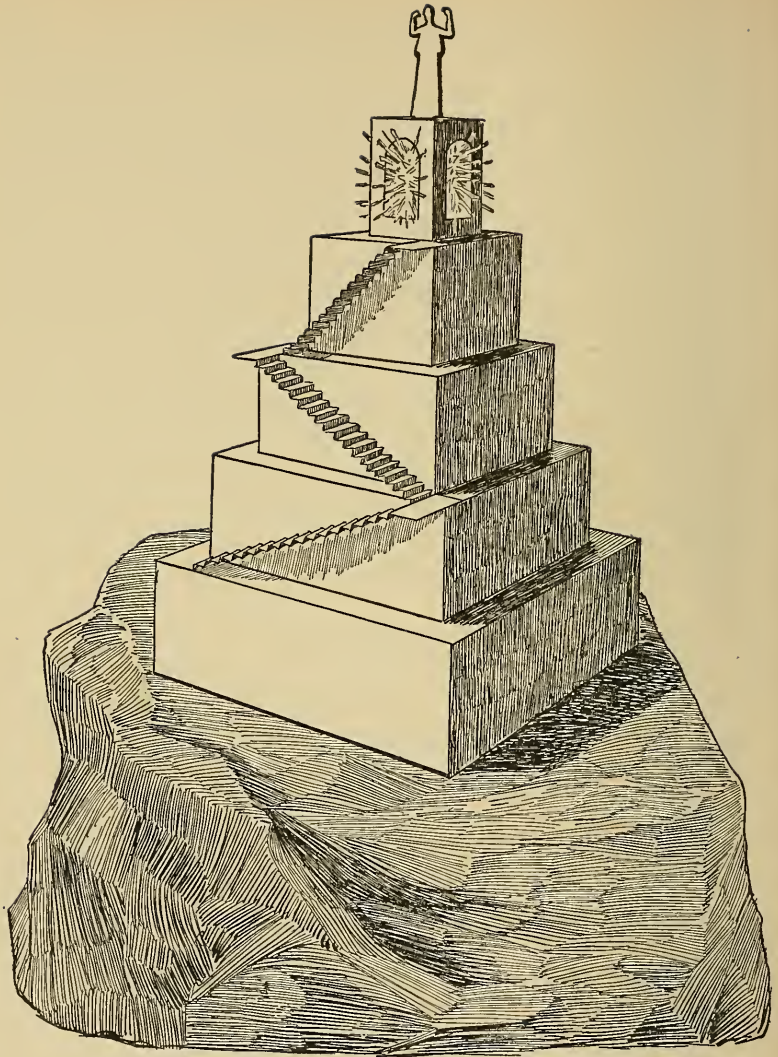

Cardboard Pharos of Alexandria

## CHAPTER XXI

### THE PHAROS OF ALEXANDRIA AND THE MAUSOLEUM OF HALICARNASSUS



LAY that you are Sostratus of Cnidus, a great architect, and that you live in the city of Alexandria, on the coast of Egypt. Here there is a King called Ptolemy, who desires you to erect a building different from any ever known; he wants something grand, original and unique, an immense structure adapted to an entirely new purpose. You must make it of white stone and do your very best, for you are to have the honor of building the "Pharos of Alexandria,"

#### The First Lighthouse Ever Known

Think what that means: When it is finished the people from other countries will see your Pharos and wonder why it never occurred to them to build a lighthouse, and they will hurry to erect similar structures on their coasts, that sailors on all the seas may have guides in times of danger and not be dependent upon bon-fires burning at the entrances of harbors. These chance watch-fires are now the only kind of lighthouses the people have, so get ready your material and make preparations for building, that you may help the poor sailors. Remember, though, that we are

living in the third century B.C., and that we are not in the United States but on the island of Pharos.

Select the eastern extremity of the island for

### Your Building Lot

It happens that your lighthouse will be on an island in the identical Mediterranean Sea in which the Colossus was reared, only

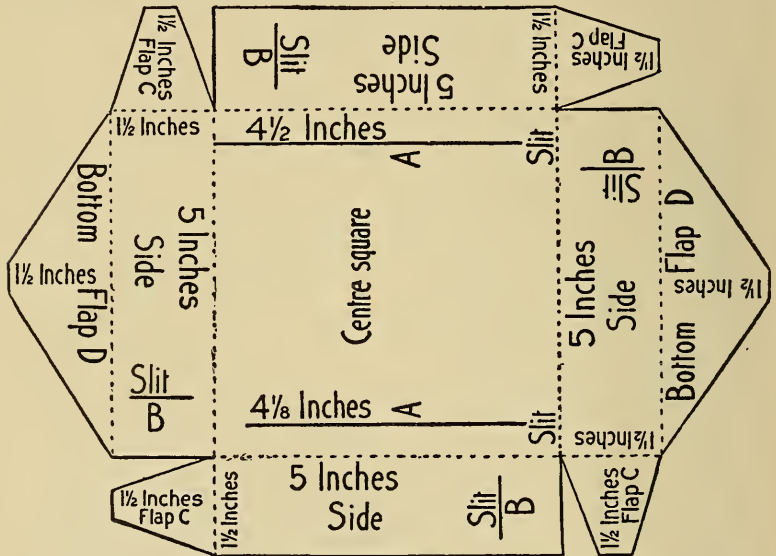
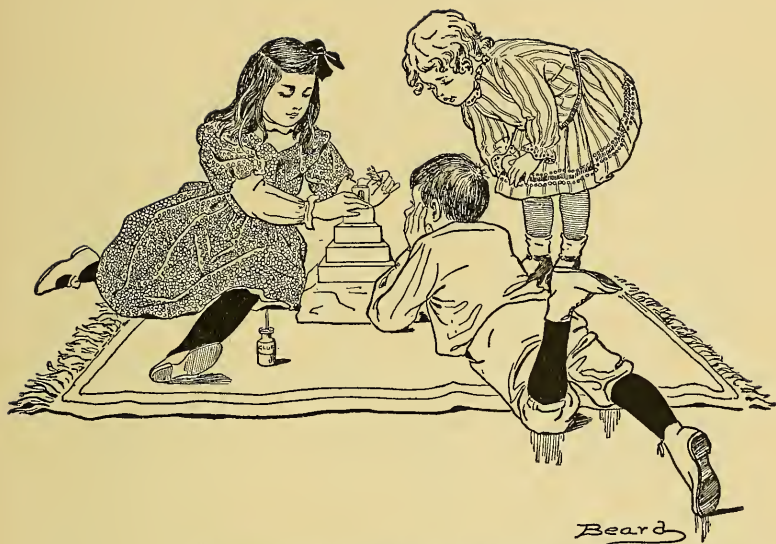

Fig. 315.—Foundation of Pharos of Alexandria.

not on the same side of the water. The island of Pharos has a neck of land, built by men, which stretches through the water to the city of Alexandria, making it easy to go back and forth for building material. You must have plenty of ground space for your new style of beacon-light, because the foundation is to be very large, about six hundred feet square, and the building





Building the Pharos of Alexandria

will be many stories, growing smaller and smaller in size as the stories extend upward. The lighthouse must be five hundred feet high, that the light may be seen miles out at sea.

Stiff, white paper will answer for the stone.

### Cut the Foundation

piece like Fig. 315 with a square centre measuring five inches along the dotted lines on each of the four edges. Near two of the edges are long slits (A A). Extending out from the centre

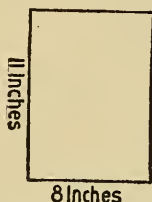

Fig. 316.—Begin with a piece of paper like this.

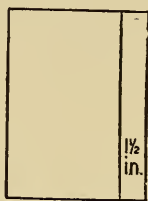

Fig. 317.—Run a line across one side.

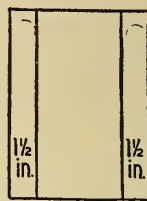

Fig. 318.—Make another line on the opposite side.

square are the four sides of the square, each an inch and a half in depth. On one end of each side there is a flap, C, at the opposite end a slit, B, and two of the sides have an extra extension, or bottom flap, D. Cut all of the heavy lines and carefully crease the dotted lines. The best way to make Fig. 315 is to cut a piece of paper eight inches wide and eleven inches long (Fig. 316). Run a line lengthwise across one inch and a half from the outer edge (Fig. 317); repeat the same on the opposite edge (Fig. 318); then mark a line across each of the ends three inches from the edge (Fig. 319). Make another line midway between this line and the edge at each end, which will bring the division one inch and a half from the edge E, E (Fig. 320). Crease all the lines, bend-

ing them inward. Open out the paper after each folding, and when all lines have been creased and opened you will find it very easy to mark and cut the sides and flaps of Fig. 315.

Cut three more papers for

**The Next Three Stories;**

divide them with lines like Figs. 316, 317, 318, 319, 320, and cut them like Figs. 322, 323, 324. The centres of these must each be

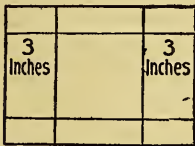

Fig. 319.—A line across each end.

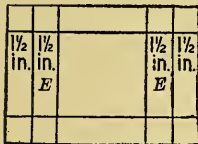

Fig. 320.—Another line will divide the space at each end.

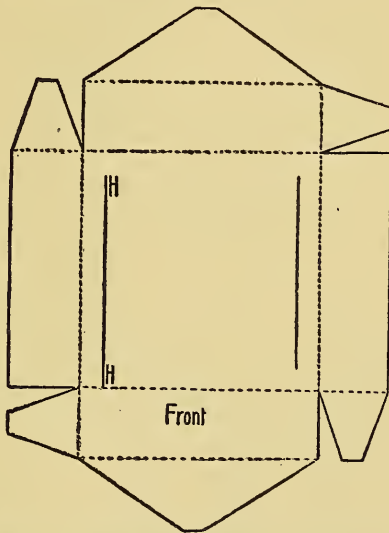

Fig. 321.—First story of Pharos of Alexandria.

smaller than the last, measuring respectively four, three and two inches square, but the depth of the sides remains the same. The size of your second-story paper will be ten by seven inches, the third, nine by six inches, and the fourth, having the bottom flaps, measure one instead of one and a half inches, as do the

others, requires paper seven by five inches. Figs. 321, 322, 323, 324 are given to show the relative sizes of the four stories when

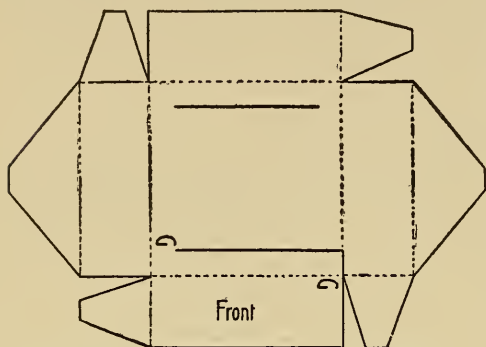

Fig. 322.—Second story of Pharos of Alexandria.

the paper is cut and laid out flat; the diagrams are also intended to explain the cutting of the slits on the centre squares. Notice that in the first story (Fig. 321), as in the additional three stories, neither of the ends of the left-hand slit reaches to the edge of the square, while the right-hand slit (H H, Fig. 321) touches at one edge. In the second story (Fig. 322) the right-hand slit not only runs to the edge of the square, but there turns at right angles and extends through the edge of the paper (G G). The right-hand slit of the third story (Fig. 323) differs from the

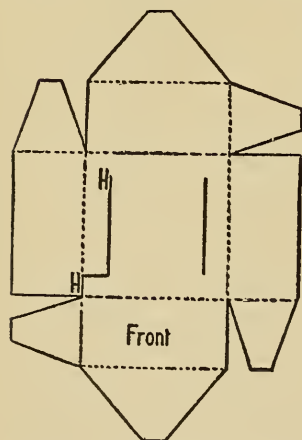

Fig. 323.—Third story of Pharos of Alexandria.

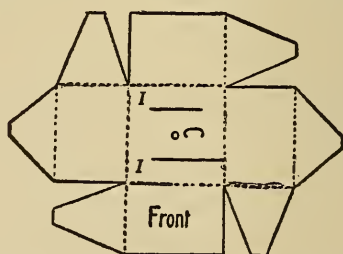

Fig. 324.—Fourth story of Pharos of Alexandria.

other two; it runs within a short distance of the edge of the square, where it turns at right angles, making a straight line to the adjoining side of the square, there turning again at a sharp angle; the slit reaches entirely through the edge of the paper H, H (Fig. 323). In the fourth story (Fig. 324) the slits are cut like those in the first story I, I (Fig. 324), being the long slit. Fig. 325 gives the diagram for the fifth story, which is the top one.

**This Room**

has large openings in the four sides to allow the beacon-light to shine out into the dark night. The centre of the diagram (Fig.

325) is one inch square; two of the sides have slits cut near each side edge of the windows; on the other sides of the squares are extending flaps.

Cut all the heavy lines, and bend inward and crease all the dotted lines, then put the top story together in proper form by sliding the four side edge flaps through the slits, which will bring the edges of the sides together, forming the four corners of the room. Bend back and crease down the portion of the flaps which extend inside of the room; do this to make the fastenings secure. Use strips of bright-red and orange-colored tissue paper cut into fringe on one edge and twisted together into a bunch, as in Fig. 326, for the

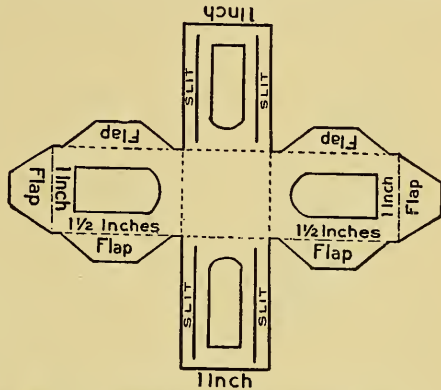

Fig. 325.—Fifth story of Pharos of Alexandria.



Fig. 326.—The pitch-wood fire.

**Pitch-Wood Fire**

which is to gleam out upon the treacherous approaches to the harbor.

Having fuel for the make-believe fire, and white stone, or paper, cut ready for building, your lighthouse may be erected in a few moments. Pierce a small hole in the exact centre of Fig. 324 C, and bend down the sides, allowing the side flap of each to extend around the corner and on the outside of the adjoining side. Slip the end of each flap through the slit which it covers, shown by B, Fig. 315, and bend back the end that comes through on the inside; fit the end of the fire (Fig. 326) tightly into the hole C on the top of Fig. 324 and the work will resemble Fig. 327.

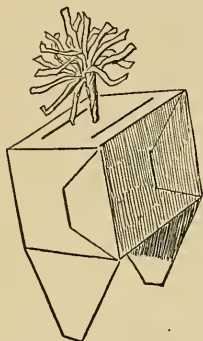

Fig. 327.—Fourth story with pitch-wood fire ready for fifth story.

Through the two slits on each side of the fire slide the two bottom flaps of the fifth or top story; flatten the ends of the flaps up tight to the under side of the top of the fourth story. Be sure to keep the front side of each succeeding story directly under the front side of the one over it, that the steps may fit in place. Fasten each lower story to the one above in the same way that you attached the fourth to the fifth.

When the Pharos is finished make the three flights of

**White Marble Steps**

leading to the top of the lighthouse. Cut the top flight (Fig. 328) of stiff white paper. Let it measure one-half inch in width and four and one-half inches in length, including the top landing.

The side extension K of the landing should be three-quarters of an inch long. Fold the flat, straight strip of paper back and forth many times, in fan fashion and crease firmly to form steps (Fig. 329). Slip the extension K into the slit I on the right-hand side of the top of the fourth story, and slide the bottom of the stairs into the slit H on the left-hand edge of the third story. Make the next flight of steps like the top ones, only longer—five

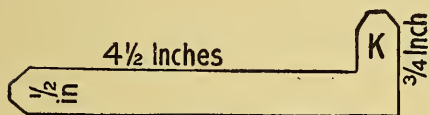

Fig. 328.—Top flight of marble steps.



Fig. 329.—Top flight with steps creased ready to attach to lighthouse.

and one-half inches in length before being creased. Place the end of the platform extension over the bottom of the top flight; run it through the slit H which turns at right angles from the edge and fasten the bottom of the steps in the right-hand slit edge (G) of the second story. Attach the third flight of marble steps diagonally across the second story in the same manner. The paper strip for these last should measure when flat seven inches in length.

The real Sostratus of Cnidus had a

### Natural Island

on which to erect his lighthouse, but you may have the fun of making one for your Pharos. Find a box a little larger than the lighthouse and cover it loosely with any kind of stiff cloth; have the cloth smooth and tight only over the space on which the Pharos is to stand. On all the other portions of the box the covering should be irregularly placed, so that it will jut out in

places; fold in others and have as much the appearance of an immense rough rock as possible. If the box is of pasteboard, sew the cover on with a stitch here and there; if of wood, tack the cover on. When ready glue or

### Tack the Island

on a foundation of wood or one of heavy pasteboard covered with sea-blue cloth or paper to represent the waters of the Mediterranean Sea; give the island a very light coat of varnish or glue, except the central space reserved for the lighthouse. Be careful not to allow the glue to dampen the cloth sufficiently to make it limp. While the glue is moist, sprinkle generously with sand. When dry, glue on the Pharos. Turn inward the down-hanging bottom flaps and glue them down securely to the stone. Draw the statue (Fig. 330) on white paper and cut it out. Then cut a slip up through the centre of its stand, bend the stand at the dotted line, one half of it forward, the other half backward, and paste the statue upright on top of the building.



Fig. 330.  
Statue.

If you would like to do just as the real architect Sostratus did, write your name in this way:

SOSTRATUS OF CNIDUS TO THE RESCUING  
GODS, FOR THE BENEFIT OF SAILORS

on one side of the first story of the Pharos; then paint over it with white paint so that the name cannot be seen. After the paint has dried, write over the white paint, "King Ptolemy." Sostratus of old carved his name deep on the stone wall of the



building, then plastered over it and set the King's name in the plaster. Instead of the plaster you have used paint.

Now place the Pharos in the bright sunlight; let it stand between you and the light, with the corners of one of the front edges toward you, and see how well it appears, and how closely the colored tissue resembles real fire burning and shining brightly from the top openings. Make tiny paper boats, not over an inch in length, with wee paper sails, and scatter them on the make-believe water. The contrast in size of the Pharos and boats will give a faint idea of the huge proportions of the lighthouse. Call in

#### **Your Friends**

and let them enjoy the lighthouse with you; tell them they must pretend that the structure is gigantic in size, that the laborers were paid only twenty cents a day, and even with such low wages, the Pharos cost over a million dollars. Explain to them how all lighthouses of the Roman world were named Pharos, after your building, because yours was the first and marks an epoch in the world's history. Say to the boys and girls that this white building you are showing them is one of the Seven Wonders of the World, and beside being very beautiful, it is one of the most useful of all the "Seven Wonders." You must make believe that your Pharos was completed in the year 282 B.C., and remained standing sixteen centuries.

#### **The Mausoleum of Halicarnassus.**

Turn a square or nearly square pasteboard box upside down. On the centre of the top glue a pasteboard cella made like the one in the Temple of Diana, Chapter XXIII. Surround the cella with paper pillars made in the same manner as those in Chapter XXIII, and glue them along the four edges of the box. Cover

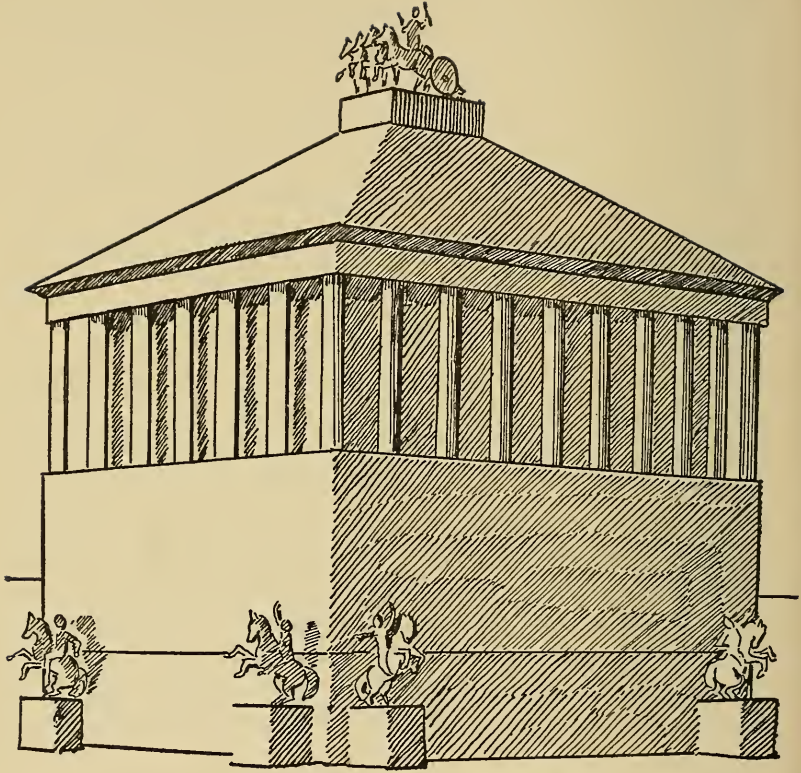

Fig. 331.—The Mausoleum of Halicarnassus.

all with a pasteboard ceiling glued on; then make a pyramid of white pasteboard, similar to the Egyptian pyramid, but let this one have a flat top. Fasten the pyramid on top of the ceiling and paste four paper horses with chariot and driver on a small box on top of the pyramid. Glue the structure on a board and make two small boxes for each ground corner. Fasten these in place and paste a paper horse with rider on top of each box, then your Mausoleum will be finished (Fig. 331). The building should be white. The original was a monument in memory of Mausolos, and was built by his wife Artemisia. It stood in the city of Caria on the southwestern tip of Asia Minor. in the year 353 B.C.

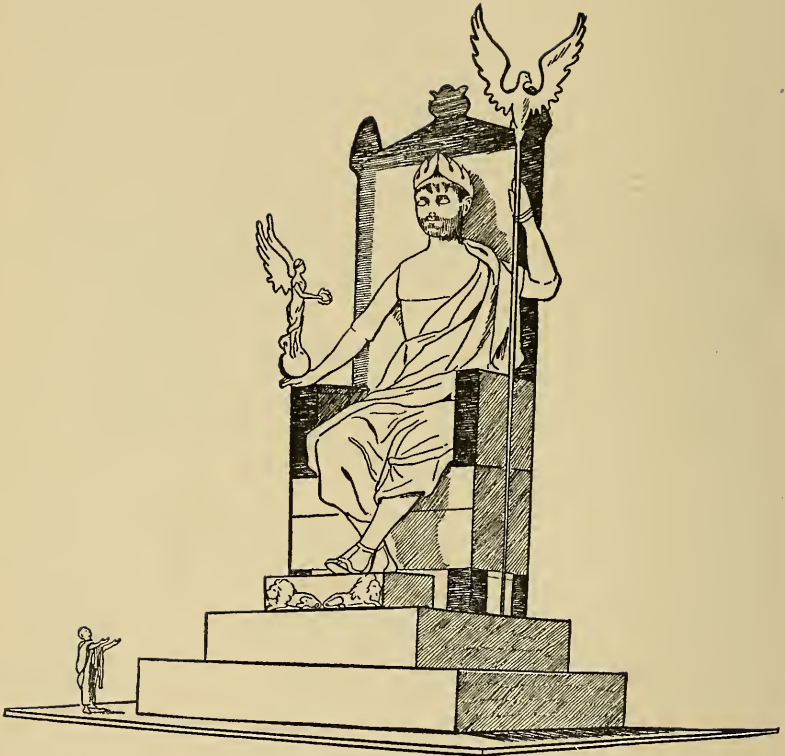

Fig. 345.—Your Little Statue of Zeus

## CHAPTER XXII

### THE STATUE OF ZEUS AT OLYMPIA



MAGINE that you see before you a majestic white statue of gigantic size, made of ivory, seated upon an immense throne of ebony, ivory, gold and precious stones, and wearing upon his golden hair a crown of enamelled green olive leaves. Over one shoulder is thrown a mantle of glittering gold, embroidered in white lilies, which falls down over his ivory body across the knees. In one hand he holds the winged figure of

Victory, in the other a long, slender sceptre crowned with an eagle, and on his feet are rich golden sandals. There: Was not that worth seeing? You have been looking at Zeus of Olympia, the most beautiful and wonderful statue ever made by Phidias, who lived ages ago and modelled Zeus about the year 439 B.C.

You can make a little statue of Zeus, but you must pretend that

#### You Are the Sculptor Phidias

and that you are actually modelling the real giant statue. Make believe that hundreds of elephant tusks have been sent to you from distant regions to supply enough

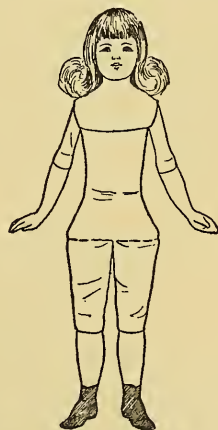

Fig. 332.—Make Zeus of a doll.

ivory for the work, and that you have an abundance of gold, precious stones and ebony. Make Zeus of a doll (Fig. 332) five and one-half or six inches in length. Pry off its wig, then give

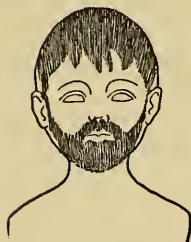

Fig. 333.—Gild hair, beard and mustache.



Fig. 334.—Gild hair at the back.



Fig. 335.—Gold sandals on the feet of Zeus.



Fig. 336.—Fold the paper for cutting crown of olive leaves.

the doll a coat of varnish. Should the arms be flat, round them out with a layer of raw cotton glued on and paint the doll white all over. You must make the entire doll absolutely white.

### Gild Hair, Beard and Mustache

on the head (Figs. 333 and 334). Gild the sandals (Fig. 335). Make a crown of green tissue paper olive leaves. Fold and cut like Figs. 336 and 337, and fasten together



Fig. 337.—The crown of olive leaves.

on the back of the head with glue. Bend and bind Fig. 338 into a sitting position with feet crossed; keep the statue so until you glue it on the throne. Cut the

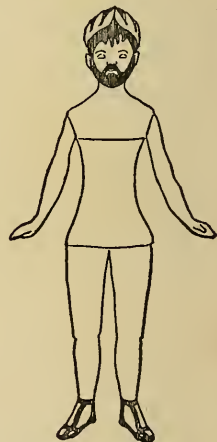

Fig. 338.—Zeus is ready for his robe.

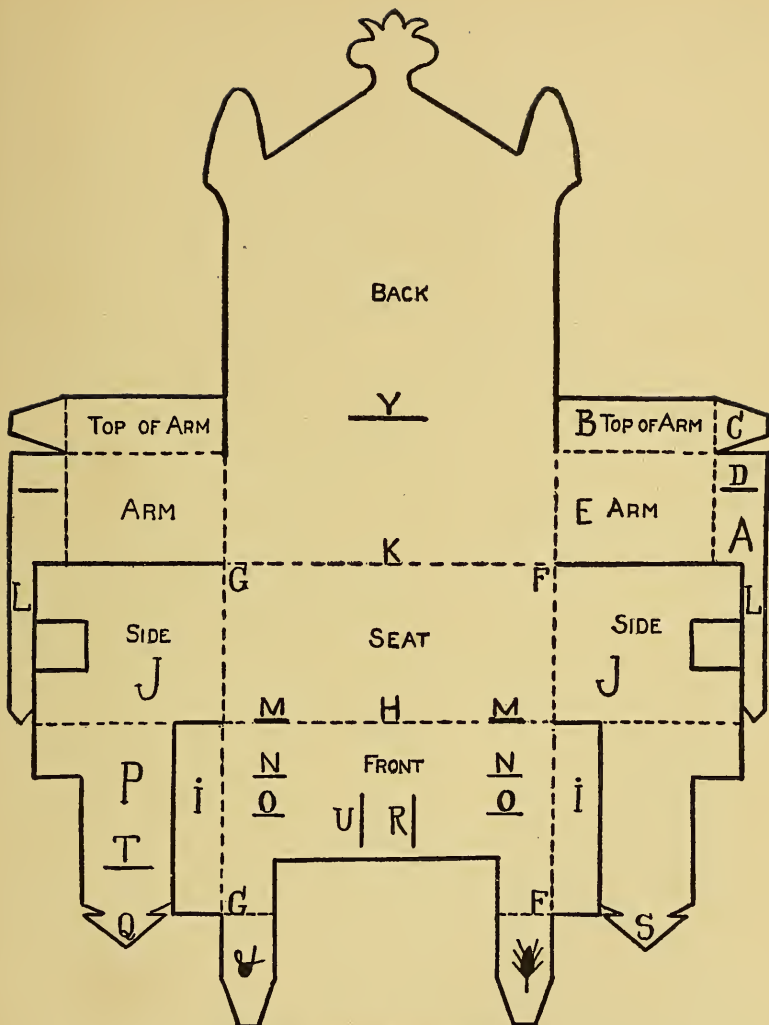

Fig. 339.—Make the throne like this.





**Throne of White Cardboard**

Fig. (339); the back, seat and front from top of centre ornament to extreme edge of front are six and three-quarter inches. The seat is one and one-quarter inch wide and two and three-quarter inches long. The arms are one inch high and the top of arm half an inch wide; the length of arm is an inch and a quarter. The front is one inch wide, the feet G and F, on each side are half an inch long not including the flaps. Length of back of throne is four and one-half inches. Each side is an inch and one-quarter wide; their greatest length, counting the entire length of one of the feet, is an inch and a half. The width of back piece (Fig. 340), not including X and X, is two and three-quarter inches. The sides X and X are one and one-half inch in length, as they fit exactly the under side of the throne sides J and J.

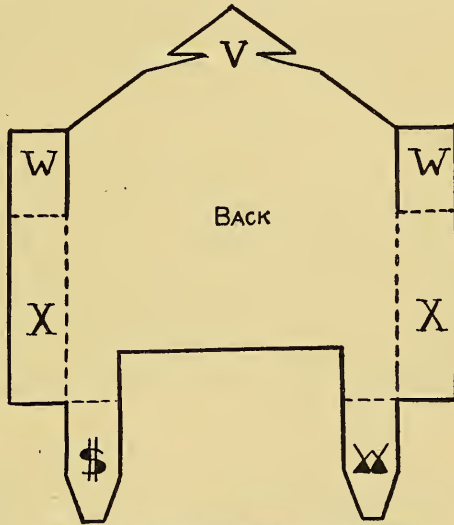

Fig. 340.—An extra back-piece for the throne.

**Lightly Score,**

then bend dotted lines and cut heavy lines. Bend inward the side part A (Fig. 339) including D and L; then bend forward the top part B; slide C through D from outside and bend inward

the box-like arm at E. Bend the other arm likewise. Bend backward the sides extending along the dotted lines F F and G G, then the front along dotted line H; at the same time slide I and I against the inner sides of the throne J and J. Bend forward the back of the throne at K. Bring forward the arms and run L and L through M and M, then pass L and L forward through N and N, and slide them back through O and O. Bring the extension P, including T and Q, across the front; run the tongue Q through R. Bend the left side, passing S through T and U, which fits directly under T; S must go through the two slits to the under side of the chair.

#### Use the Blade of a Penknife

in sliding tongues and flaps through slits and use it to straighten out the points of tongues after they are through the slits. Bend down and backward W and W (Fig. 340); then bend back X and X and fasten Fig. 340 to the throne by sliding V through Y on back of throne. Rest the seat of throne over W and W and the sides J and J (Fig. 339) over X and X (Fig. 340). Attach the throne to the

#### Upper Dais

by lower flaps. Fig. 341 shows the upper dais. The four sides are each one inch high, its top is three and one-half inches on each of the sides; all four extensions are one inch and a quarter long, tongues not counted, and the four slits are each an inch and one-quarter from the edges of the sides.

The two slits marked, one with a square, the other with a diamond, hold the flaps of the footstool (Fig. 342) marked with same designs. In the diagrams of footstool and dais the slits are marked with designs like the designs on flaps and tongues, which slide through them:

Bring the two correct parts of the upper dais (Fig. 341) together by matching them, as heart to heart, etc. Cut heavy

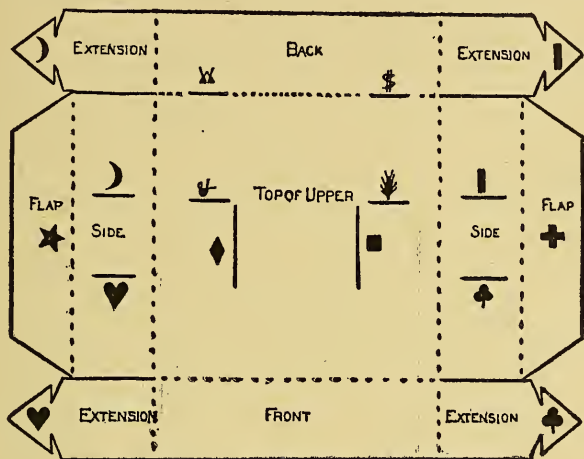

Fig. 341.—The upper dais of the throne.

lines, lightly score and bend dotted lines of the upper dais and put it in shape. Make the top of

### Footstool

(Fig. 342) an inch and a half long and one inch wide; let the front, back and sides each be half an inch high, the back extensions one inch long, the two side flaps each one inch long, front extensions an inch and a half long, not including tongues. Cut heavy lines, score lightly and bend dotted lines and slip tongues through slits.

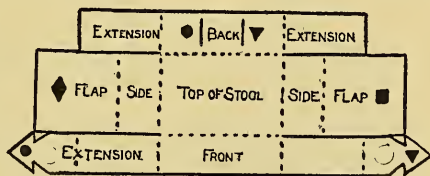

Fig. 342.—The footstool for the feet of Zeus.

**Attach the Stool**

to upper dais by bottom side flaps; bend the flaps up flat against the under part of the dais. In the same way fasten the throne on the upper dais by sliding the four down-hanging extensions through the four remaining slits on top of the upper dais marked

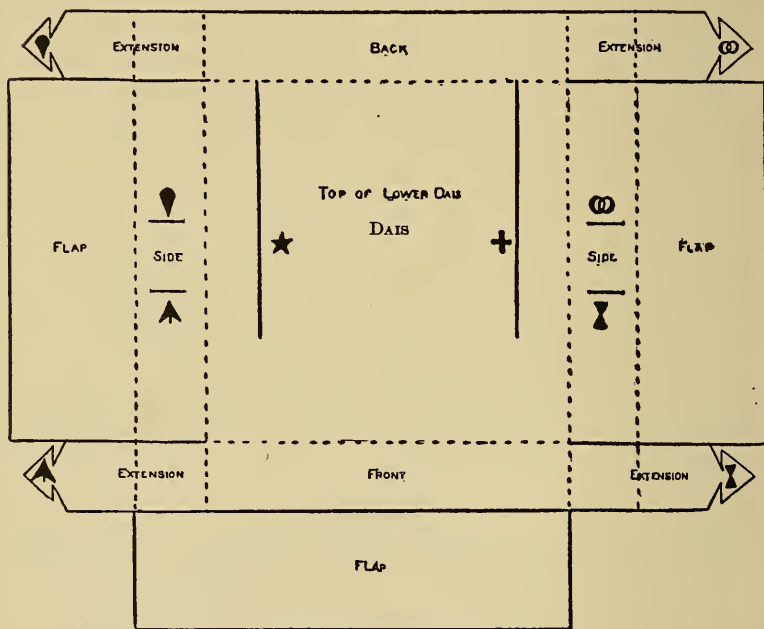

Fig. 343.—The lower dais.

with the same designs. Bend and put together the lower dais (Fig. 343) and fasten the upper dais on it. Make the lower dais five inches square on top and one inch high. Glue the bottom flaps of lower dais down on stiff cardboard or thin wood, in size about eight by ten inches.

**Inlay the Throne with Ebony**

by painting a black band across the top, down each side of the back and down the front of the arms; keep the lines straight and neat. Gild the centre and two side ornaments on top of the throne.



Fig. 344.—The lion panel for the throne.

Trace the panel with the two lions (Fig. 344), gild the lions and gum the panel on the front of footstool; then

unbend Zeus and place him on his throne, bringing him well to the front that his feet may rest on the footstool. Fasten the statue firmly in place with glue and pins. Pin one folded end of a strip of smoothly ironed starched cloth on the back of Zeus, bring the cloth up over the left shoulder down across the knees in folds like those in Fig. 345, the statue of Zeus, and with glue and pins

**Fasten the Drapery**

loosely here and there, then gild the entire strip of cloth. Make the sceptre of a headless hat-pin. Trace the gold eagle from Fig. 346; gild and cut it out, then taking a stitch through the eagle's body with the hat-pin, slide the eagle up to the top of the pin and glue it in place. Make Zeus grasp the eagle-crowned sceptre by binding his hand and sceptre tightly together with thread. Add a little glue to make sure they stick fast; steady the sceptre by running its point down into the small needle hole that has been previously punctured in the dais, and paint the sceptre white.



Fig. 346.—Cut out a gold eagle.

Trace and cut out the

**Winged Figure of Victory**

(Fig. 347), glue it to the empty hand of Zeus and glue the hand tight on the top of the arm of the throne. Then, to give an idea of the immense size of the statue, place a one-inch doll in front of the throne, glue a bit of drapery on it, and let the doll represent a worshipper at the shrine of Zeus. Play that the ivory, gold and ebony throne is glittering with precious stones and golden pictures from the stories of the gods, and that the arms of the throne are supported by two sphinxes.



Fig. 347.—The winged figure of victory.

The real statue was in the chief temple of Olympia in Greece, where the Olympic games were held every fourth year, and Zeus was so large, it was said, that

**Should He Rise from His Throne**

he would lift the roof off the building; also, that the statue was the supreme masterpiece of art. Everyone was anxious to see it. The people believed that should one stand before the figure and gaze upon it, he would immediately forget all worry and care. Possibly this charm may be transmitted to your little Zeus. The next time you are worried, try it, and see if you do not find yourself smiling as you contemplate the little statues.

You might let your young friends come to see your Zeus for four successive days and play that each day is a century, because for four centuries the real Zeus attracted crowds of people, as it was held a calamity to die without having seen Zeus of Olympia.

## CHAPTER XXIII

### THE TEMPLE OF DIANA AT EPHEBUS

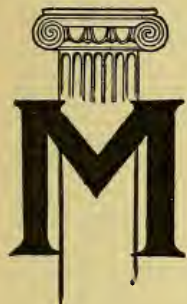

ANY white marble columns, twenty-eight in all, will be needed for Diana's Temple, but the columns are so easy to make, that you will think it fun and wish more were required. Use stiff white paper, pretending it is marble, and cut all the columns according to Fig. 348. Keep strictly to the given dimensions, being careful

to cut each column exact and true and perfectly even. Slash up the bottom and roll the entire column on a long pencil to make it curve, then take it off and spread strong glue or paste along the marked edge and wrap the column around a smooth, straight stick two inches in circumference, lapping the unmarked lengthwise edge over the glue-covered edge of the column. Press the edges together until they cling tight, then remove the column; bend out the slashed bottom and roll the two top extensions as in Fig. 349. Now

#### Look at Your Column;

see how gracefully the capital curves into a roll on each side, reminding one of a blossom on the end of a stem. The column you have made is called Ionic, and when you examine the columns or pillars of buildings, you will easily recognize those with Ionic capitals. It was principally because of the beautiful rolled capitals crowning its columns that the temple of Diana was

known as one of the Wonders of the World, for it was the first structure that utilized this beautiful style of architecture.

Find a piece of extra stiff white cardboard, nineteen by eleven inches, and on it draw

### The Ground Plan

of your temple (Fig. 350). The distance from the outside edge of one ladder-like strip to the outside edge of the other is nine

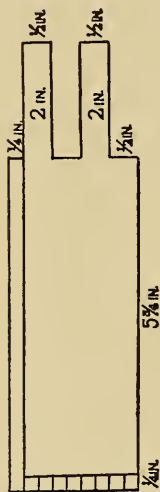

Fig. 348.—Cut all of the columns like this.

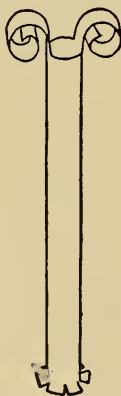

Fig. 349.—The finished column

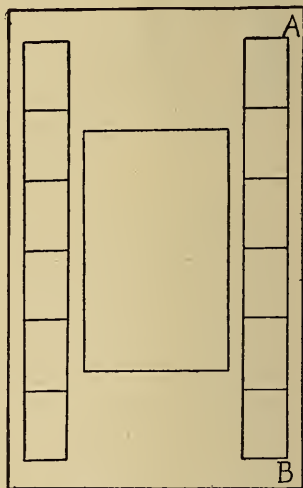
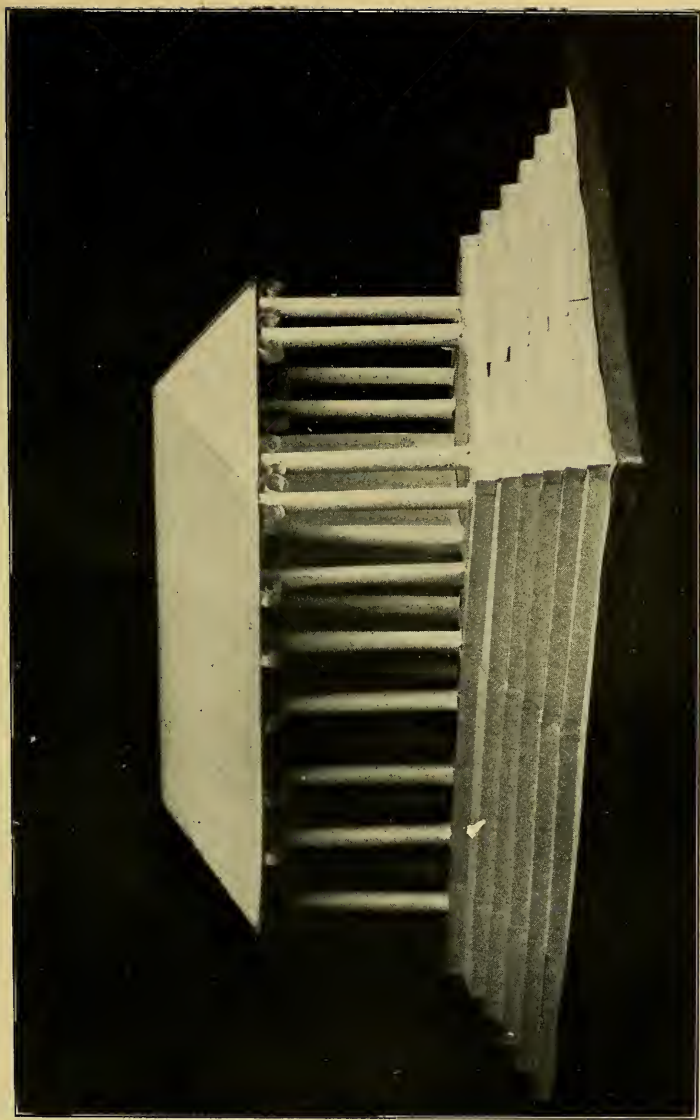

Fig. 350.—Ground plan of Diana's temple.

inches. The strips are each sixteen inches long, two inches wide and divided into six spaces. Make the spaces by folding a sixteen-inch strip of paper exactly crosswise through the centre, then folding each half of the paper three times. Place this strip along the edge of the sixteen-inch lines on the ground plan and mark the spaces. Draw the oblong for the cella on the centre





Your Miniature Temple of Diana.



(Fig. 350). Make it four inches wide and ten and one-half inches long, leaving half an inch space between this oblong and the inner sides of the ladder-like strips. Take one column at a time and glue the slashed portion firmly on the ladder-like strip. Begin at A, Fig. 350, and



Fig. 351.— Circle shows where to place first column.

erect the outer row of columns, allowing each column to stand immediately along the inside of the outer line AB, Fig. 350, with its exact centre over the short cross-line, as in Fig. 351 (circles indicate columns). Each column must stand erect and plumb. Place the next row of columns just within the long inner line as in Fig. 352. In the same way erect the second

**Erect the Outer Row of Columns,** allowing each column to stand immediately along the inside of the outer line AB, Fig. 350, with its exact centre over the short cross-line, as in Fig. 351 (circles indicate columns). Each column must stand erect and plumb. Place the next row of columns just within the long inner line as in Fig. 352. In the same way erect the second



Fig. 352.— Position of first double row of columns.

double-columned row on the opposite side of the foundation and glue together the sides of the rolled capitals which touch at the top of each pair of pillars on both rows.

For the oblong centre,

### Make a Cella

of a coverless white cardboard box minus the two ends (Fig. 353). Let the cella be four inches wide, ten and one-half inches long, and five and one-half inches high. When making any article of cardboard, always lightly score every line intended to be bent; this is very important to insure good work. Glue the cella or inner temple on the boundary lines marked for the purpose on

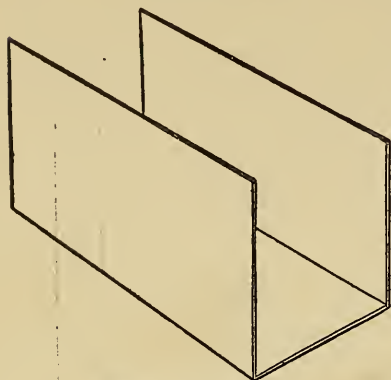

Fig. 353.—The cella.

facing the walls of the cella. Trace on cardboard and

the centre of the foundation board, and glue the outside of the two walls firmly to the edges of the rolled capitals of the columns which touch them.

Cut the dais of cardboard five by three inches, and bend it like Fig. 354; have it three-quarters of an inch high and glue it on the floor of the cella (Fig. 353) two inches from the back edge with its open sides

#### Cut Out the Goddess Diana

(Fig. 355). Bend the extension beneath Diana's feet half forward and half backward, then glue Diana on top of the dais in the centre at the back.

Build on the ceiling and roof of the temple. Make the ceiling of cardboard ten by sixteen inches, and cut the two gables, one for each end of the roof, like Fig. 356, two and three-quarter inches high and ten inches long, not counting the extensions on the three sides, which must be bent and glued to the ceiling and roof. When the gables are fastened securely on each end of the ceiling, cut the roof of white cardboard seventeen by twelve inches, bend it lengthwise through the centre and glue it on top of the ceiling by fastening the ends tight to the up-

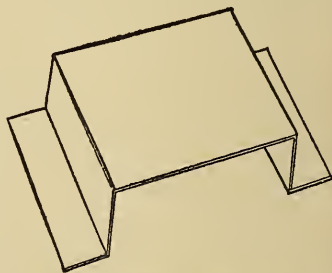

Fig. 354.—Make a dais for Diana.

right gables. Allow the roof to extend a trifle beyond and over the edges of the ceiling and also project half an inch over front and back of the temple. Fit the roof-covered ceiling over the top of the temple; see that everything is properly placed, then remove the ceiling; drop a little



Fig. 356.—The gable.

glue on top of each roll of the capitals on all of the pillars, again adjust the roofed ceiling and hold it steady until it adheres firmly to the temple.

Take a box eleven inches long, nine inches wide and three inches high; turn it bottom side up and glue your foundation with its stately temple securely on the box.

Use white passe-partout strips to fasten the box down tight on a light-weight board, twenty-seven by sixteen inches.

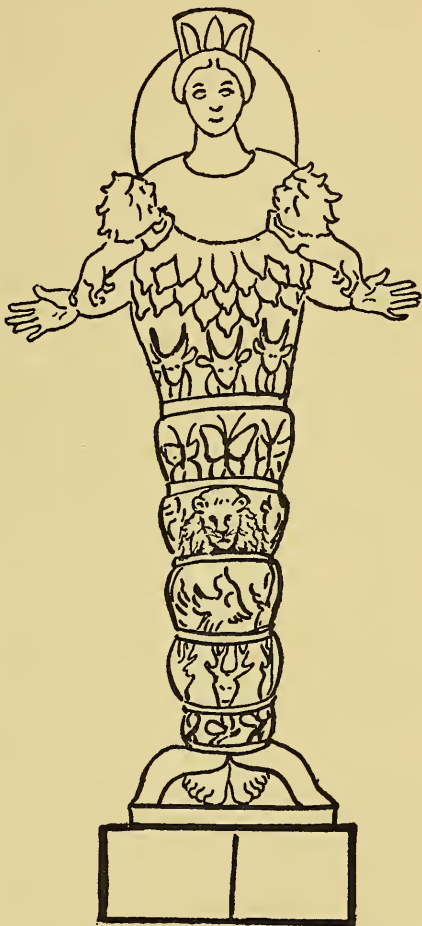

Fig. 355.—Statue of the Goddess Diana.

Get medium light-weight, smooth white water-color paper, for making

### **The Marble Steps**

on each of the four sides of the temple. Each flight must be made in two pieces or sections. In all there will be eight sections. Cut paper for the right-hand section of front steps nine and one-half by six inches, the left-hand front section nine by six inches. Make the two sections for back steps the same.

Cut the right-hand side steps in sections thirteen by six inches, and twelve and one-half by six inches. Make the other side sections the same.

Now be very careful in your measurements. If your measurements are not exact your steps will not fit together. Divide each section of paper lengthwise from side to side into half-inch spaces by drawing twelve lines across, beginning half an inch from the top of the paper. This will make thirteen spaces (Fig. 357) which, when creased backward and forward, fan fashion, will form seven steps, counting top and bottom landings or treads. Take the longest section of the front steps and square off one end with lines half an inch apart and of varying lengths running down across the first line (Fig. 357).

### **Begin at the Top**

square, C, and draw a diagonal line across it; continue the diagonal lines across every other descending square (Fig. 358). Cut away the squared marked paper from the diagonal lines and the squares marked D D D D D D in Fig. 358 as shown by heavy line in Fig. 359. This makes the corner of the stairs. Lightly score all the horizontal lines, then crease the steps backward and forward along the horizontal lines. Make the other half section of front steps same as first, with the exception that

the corner must run out to the left instead of the right hand, so draw the vertical lines (Figs. 357, 358, 359) at the left side of the section and make

that corner like the right-hand one, only reversed.

**Make a Brace**

for the centre where the two sections join, of a two and one-half by three-inch piece of cardboard ruled in half-inch squares and cut like the heavy line on Fig.

360. The steps on this must be cut still deeper, each one-half inch, according to the heavy lines in Fig. 360, and the extensions bent over at dotted lines as in Fig. 361. Fit and glue the straight edge of the left-hand front section of steps on this brace; have the brace flush with the edge of the steps. The brace should not reach to the tops as the tread of that step lies upon the foundation of the temple. When the brace is on, lap the edge of the right-hand section over

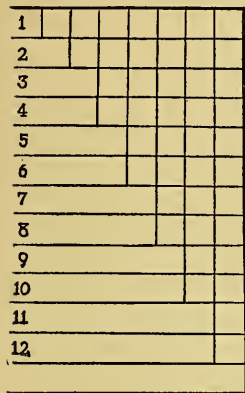

Fig. 357.—Vertical lines mark the end of the steps.

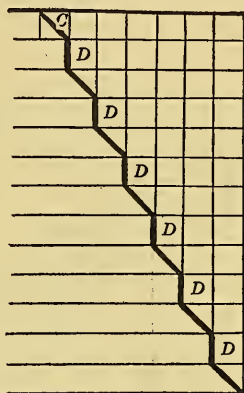

Fig. 358.—Draw diagonal lines across.

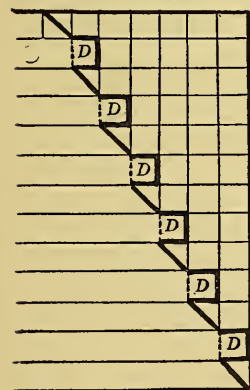

Fig. 359.—Cut away the squares as shown here.

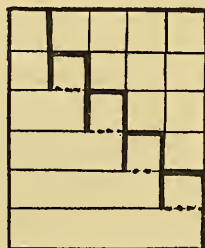

Fig. 360.—Brace for centre of steps ready to be cut.

the left-hand section half an inch; glue the two together, and the front flight of steps will be finished.

Make the back flight in like manner.

### The Side Steps

have no square corner extensions like Fig. 359; the corners are cut according to the heavy line in Fig. 358. Each of the

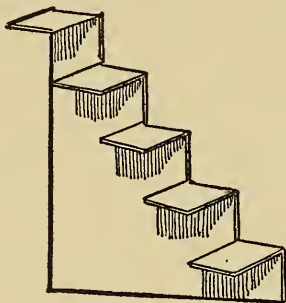

Fig. 361.—The finished brace.

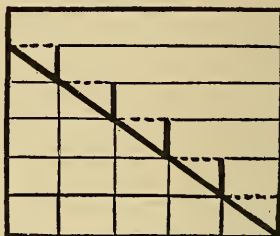

Fig. 362.—Brace for corner of steps ready to be cut.

side flights of steps must have its central brace, the same as the front (Fig. 361), and the two sections of each side must be joined together as you joined the front flight.

Make four more braces, one for each corner, by dividing with

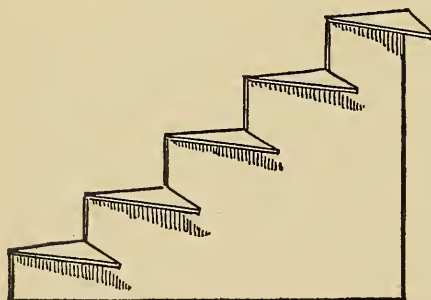

Fig. 363.—Corner brace finished.

horizontal lines a piece of cardboard for each into six half-inch spaces, then crossing these lines by vertical lines wider apart, the width being the exact diagonal distance across a half-inch square, for they must fit the diagonal edges of the steps at the corners



of the four flights. There must be five of these wider spaces (Fig. 362).

Cut along the heavy lines and bend down the point along dotted lines (Fig. 363).

### **Fit and Glue**

one of these braces at each end of the two side flights, then glue the side flights on the sides of the temple foundation and the ground board. Fasten the extensions D D D D D D (Fig. 359) of the corners of front and back steps to the side steps by binding them over and pasting them on the side steps. At the same time glue the front and back steps on the temple foundation and ground board.

Set the temple up on a double pile of books placed on a table. The temple must be elevated that your friends may look in at the open front and behold the Goddess Diana. Your beautiful little classic temple will give some idea of the grand original structure rebuilt in Asia about 356 B.C., whose marble columns numbering one hundred and twenty-seven, were sixty feet in height and each the gift of a king.

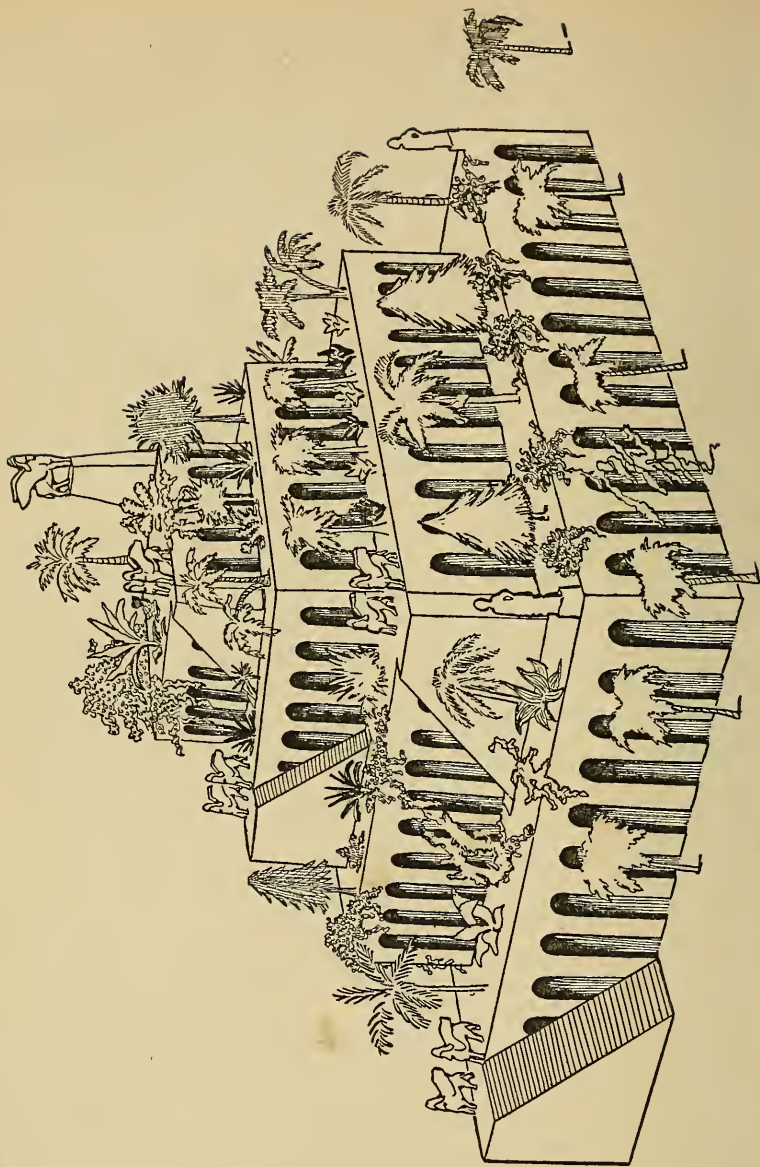

Fig. 377.—The Hanging Gardens of Babylon You Can Make.

## CHAPTER XXIV

### HANGING GARDENS OF BABYLON



MAKE believe that you are in a singular place; the city is square, filled with square lots, on which are square houses, built of square bricks, and, strangest of all, by the side of the king's magnificent square palace there stands a wonderful garden. The garden is also built square in four mighty steps or platforms, one above the other,

each supported by arches.

These are the famous Hanging Gardens and you are in the ancient city of Babylon where Nebuchadnezzar is king, and the time is about the year 580 B.C.

#### The King's Wife, Amytis,

used to live in the mountainous country of Media, and when she married and came to Babylon, she longed for the sight of a hill, so her husband, King Nebuchadnezzar, had the Hanging Gardens built for her. Pretend that

#### The Queen Has Invited You

to explore the gardens with her. Up, up the many flights of marble steps you go to the tip-top of the beautiful hill, and standing there by her side you have a splendid view of the surrounding flat country as well as of the River Euphrates, which divides the

city into two equal parts, half on the east and half on the west side of the river. The Gardens are built as high as the walls of the city (three hundred feet) so you can readily look over the walls to the stretch of land on all sides.

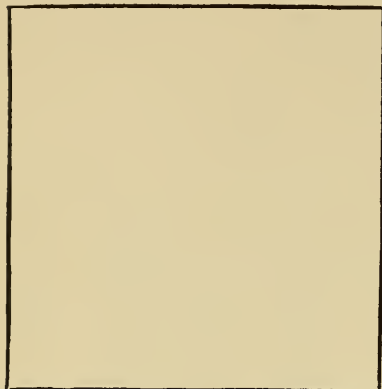

Fig. 364.—Cut a piece of pasteboard exactly square.

If you will find some very stiff pasteboard we can go to work immediately and build toy Hanging Gardens. Cut a piece of the pasteboard exactly square, measuring on each of the four sides eighteen and one-half inches (Fig. 364). Of this we will make a box-like foundation. Draw a straight line three inches from each edge, as shown by the dotted lines in Fig. 365. Take each line in turn and, placing the edge of a straight ruler along it, score the line; that means, run the knife-blade along the pencil line at the edge of the ruler, cutting the pasteboard only partially through. As each line is scored, raise the pasteboard and bend it *away* from you along the scored line, then allow the pasteboard to lie out flat again.

After all the lines are properly scored, cut the lines A A

Stiff Pasteboard

### Stiff Pasteboard

we can go to work immediately and build toy Hanging Gardens. Cut a piece of the pasteboard exactly square, measuring on each of the four sides eighteen and one-half inches (Fig. 364). Of this we will

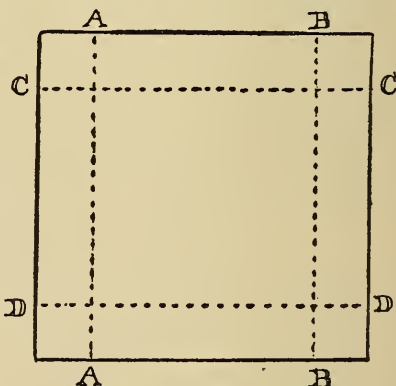

Fig. 365.—Mark it off like this.

and B B (Fig. 365) only far enough inward to meet the lines C C and D D (Fig. 365). Allowing a scant half-inch extension at each corner on the lines C C and D D, cut the corners out as in Fig. 366. Bend the four little extensions, then the sides E and F (Fig. 366). Cover the extensions with strong glue and, bending the remaining sides G and H (Fig. 366), glue the extensions, one at a time, securely on these sides.

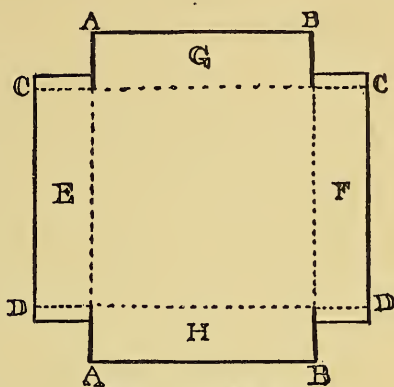

Fig. 366.—Cut like this.

### Hold Each Extension Tight

to the side until it sticks fast. In this way the cardboard will be made into a large, square box, which, when perfectly dry, must have openings cut through all the sides that it may resemble closely the foundation platform of the real Hanging Gardens.

### To Make the Twelve Openings

on each of the sides of the foundation platform, cut a strip of cardboard twelve and one-half inches long, and three inches wide. Across the entire length of the strip draw lines half an inch apart, as I I (Fig. 367). Cross these short lines by a long line running lengthwise one inch from the top edge, J J (Fig. 367). Between this line and the upper edge draw another line, running lengthwise, a quarter of an inch from the line J J, as K K, Fig. 367. You now have a strip of cardboard twelve and one-half inches long and three inches wide. Across its entire length

you have run two long lines, and across the entire width many short lines.

### Begin with the Second Division

from one end of the strip marked by the short lines, and make a dot on the centre of the line K K (Fig. 367) where this line crosses the second division. L (Fig. 367) shows the dot.

The diagram Fig. 367 is merely intended as a guide, giving only portions of the twelve and one-half inch strip you are making. Begin at the lower corner of the small division under L (Fig. 367) and draw a curved line up to L; draw another curved

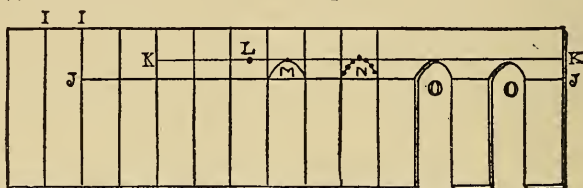

Fig. 367.—To make the twelve openings.

line from the opposite corner of the same division up to the same point. The two lines will

### Form an Arch

as in M (Fig. 367). Skip one division and draw another arch on the fourth division in the same way that you drew the arch of the second division. In like manner draw an arch in the space between the lines K K and J J of every other division on the strip. This will make twelve arched divisions, leaving a solid division or pillar at each end of the strip and also between each opening. With the point of your knife-blade

### Pierce Holes

around the edge of all the arches as shown by the arch N (Fig. 367); then with scissors cut the two sides of the second division

up to the arch and, holding the cut piece with your thumb and first finger, bend it backward and forward until it breaks away from the strip, leaving an arched opening. Smooth the rough edge of the arch by cutting away the uneven particles. Cut all arches in like manner O O (Fig. 367) and cut the least bit from across each end of your strip—not more than a sixteenth of an inch—that the strip may slide inside of the box foundation. The strip will be a guide in making all of the arches of your Garden.

#### **Stand the Box on One Side**

and slip the strip inside of it; lay the strip down flat on top of the lower side of the box (Fig. 368) and, holding it firmly in place, mark the divisions and arches on the box by running a pencil line around the edge of each opening arch of the strip. Remove the strip, and one side of the foundation will be marked ready for the twelve archways to be cut out. Repeat the markings on each of the four sides of the box foundation, cut open the archways as you cut those in the strip and you will have made a garden foundation like the first story of Fig. 369.

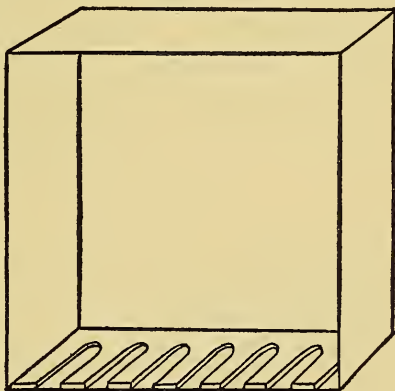

Fig. 368—Stand the box on one side.

#### **The Babylonians**

used arches to support their enormously heavy structures because arches are the strongest kind of foundations. Make another box of a perfect square of pasteboard measuring thirteen and

one-half inches on each of the four sides, to form the second platform. Mark off the two and one-half inch sides and your box will be eight and one-half inches square, with a height of two and

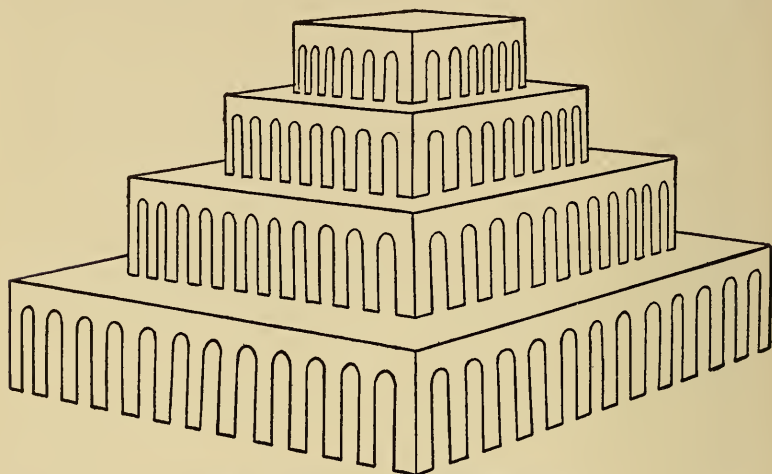

Fig. 369.—Foundation of the Hanging Garden.

one-half inches. After the glue of this is thoroughly dry, cut the arches. Use the same strip for a guide that did duty for the first platform arches. Cut four arches from one end of the strip and shave off the outside edge of the solid fifth division which forms the end of the strip where the portion has been taken off. The strip will now

#### **Fit in the Second Box Platform**

When this is all complete, make a third box still smaller, of pasteboard nine and one-half inches square. Measure off a two-inch border on every side to form the sides of the platform. The box should be five and one-half inches square and two



inches high. Cut arches in this platform with the aid of the same guiding strip of open archways after first cutting off three additional openings to make it fit the new box. You can also trim off the bottom of the pillars along the lengthwise lower edge of the strip that it may be narrow enough to fit more perfectly in the third platform.

Make the fourth and

### **Last Platform**

of pasteboard six inches square. When finished let the box measure three and one-half inches square and one and one-quarter inch high. Two more openings must be cut from your arched strip to shorten it sufficiently to fit in the last box platform, for this platform must also be cut into open arches. Build up the four platforms one on top of the other, as in Fig. 369.

Place the centre of each platform exactly over the centre of the one beneath it.

### **To Find the Centre**

take each platform in turn and lay a ruler very lightly on its top that no pressure may bend the arched sides; draw a pencil line across from the upper right-hand corner to the lower left-hand corner P, Q (Fig. 370); cross this line with another drawn diagonally across the square from the other two corners R, S (Fig. 371). The exact centre of the square top of the platform is at the dot T (Fig. 371), where the two lines meet and cross each other. Find the centre of each platform and very carefully puncture a hole through the centre with a coarse darning needle. You will have use for these centre marks when fastening the platforms together.

**The Four Different Floors**

of the original Gardens were supported by pillars and arches, as you have made yours, only the real platforms had more pillars under them. Between the pillars which formed the square of the first lower platform twelve arched passageways ran, entering

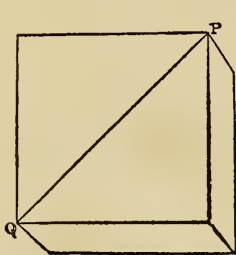

Fig. 370.—To find the centre.

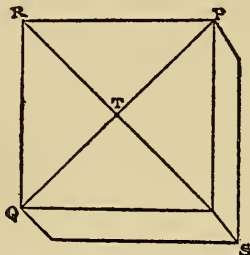

Fig. 371.—Cross this line with another.

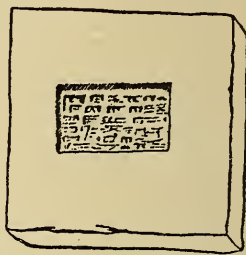

Fig. 372.—A Babylonian brick.

from each of the four sides and dividing the ground beneath, equally between pillars and passages. There were rows and rows of pillars and arches that gave the effect of a honeycomb with open-sided cells. The arches proper were formed at the top of the many pillars which supported them, and all were built of the

**Queer Square Bricks**

which had the king's name stamped on them, with other writing in a square bounded centre. The bricks were twelve inches long, twelve inches wide, and three inches thick and looked like Fig. 372. You must pretend that your pasteboard pillars between each opening are made of just such bricks and that there are many, many more brick pillars throughout the entire space beneath the floors.

### **Cut Light-Green Tissue Paper**

into strips wide enough to extend a trifle over the edge of the platforms while reaching in across the top far enough to have the inner edge of the strip covered by the platform resting over it. The tissue paper should form a flat green band bordering the entire top ledge of the first three platforms.

Cover the entire top of the fourth and last platform with the green tissue paper.

Before you can

### **Plant the Shrubs and Trees**

you must dig holes in the earth for their roots. Take each platform in turn and, with a coarse darning needle, puncture holes entirely through both green paper and pasteboard. Let the holes be in straight rows; make them on the projection or step of each platform, midway between the extreme edge and the walls of the next higher story. On the first, second and third platforms the holes should be an inch and a half apart. Pierce three holes through the top of the fourth platform, one at the back on the extreme left-hand corner and one on each side of that hole, but much nearer the centre.

### **You Will Need Ground**

upon which to erect your Hanging Gardens. Get a piece of heavy, stiff pasteboard which will not bend, or a light board about seventeen inches wide and nineteen inches long. Cover it with green blotting paper, allowing the paper to extend over all the edges. Paste the four turned-over portions of green paper on the under side of the board or ground.

Now build up the Gardens. First

**Stick a Long Hat-Pin**

through the centre of the fourth or top platform. Then run the hat-pin through the centre of the third platform; slide this up next to the top platform, keeping the sides straight and parallel. Add the second and the first platforms to the others, running the pin each time through the centre of the top of the platform. Place the structure on the ground with one of its sides flush with—that is—along the edge of the ground, and its adjoining side two

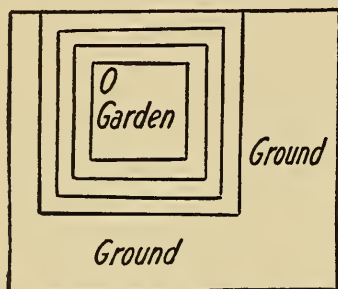

Fig. 373.—Place the building on the ground in this position.

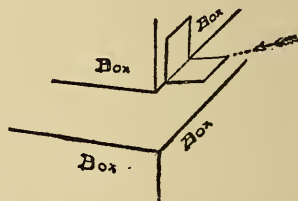

Fig. 374.—Paste the strip to the side of one box and the top of another.

inches from the adjoining edge of the ground, leaving about five inches of ground in front and four inches of ground at the other side of the Gardens. Then stick the hat-pin firmly down into the ground and leave it there until the structure is all glued together. In fitting the building on the ground be certain that it is turned so that the back of the top platform on which you have pierced the hole at the extreme left-hand corner lies along the back edge of the ground O (Fig. 373).

**To Bind the Different Parts**

of the structure firmly together and fasten the whole building to the ground, cut sixteen strips of white writing paper two inches

long and a scant half-inch wide; fold each strip crosswise through the centre; then, paste half of one strip on the fourth platform upward from the right-hand lower corner; bring the free half of the strip out flat on top of the next platform, which extends immediately beneath it, and gum down securely (Fig. 374). Bind

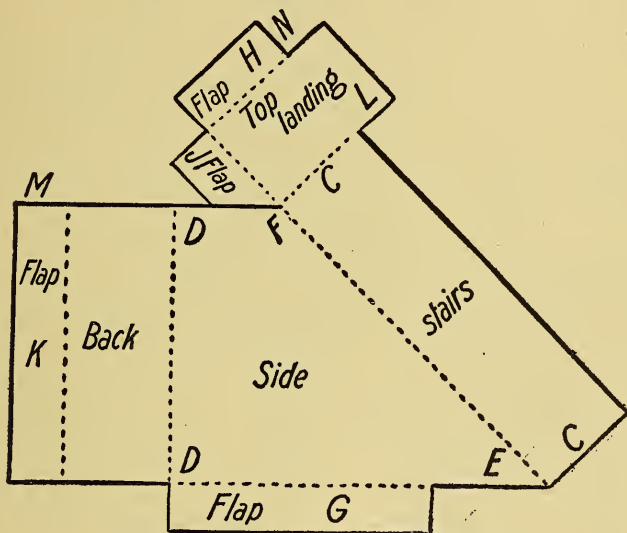

Fig. 375.—Cut the first flight of steps like this.

the other three lower corners of the top platform down to the top of the next platform in the same manner; then fasten the third to the second and the second to the first platform, also the first platform to the ground. When the paste is perfectly dry, cautiously remove the hat-pin.

#### Build the Four Flights of Steps

from stiff white writing paper. Cut Fig. 375, for the first flight of steps; make them exactly according to the dimensions or sizes

of the different parts given. You will find that the stairs themselves C, C (Fig. 375) must be four and one-eighth inches long and an inch and one-eighth wide. The height of the side of the stairs D, D (Fig. 375) is three inches. The length of the bottom of the side of the stairs D, E (Fig. 375) is four inches. The top of the side of the stairs D, F (Fig. 375) is one inch, and the width of the back, one and one-eighth inch; this should be the same width as the stairs C, C (Fig. 375) because it is intended to fit on and over the flap H that turns down from the top landing and is the same width as the stairs C, C (Fig. 375).

The height of the back is three inches. The

#### Top Landing of the Stairs

(L, Fig. 375) is one inch by five-eighths of an inch. Cut all of the heavy lines of the stairs and bend backward all of the dotted

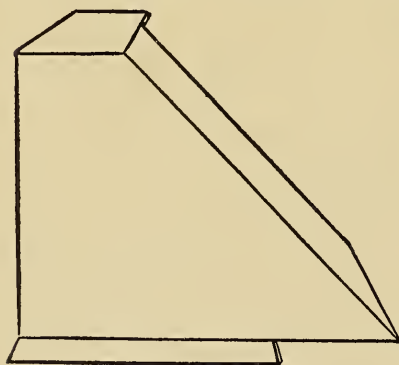
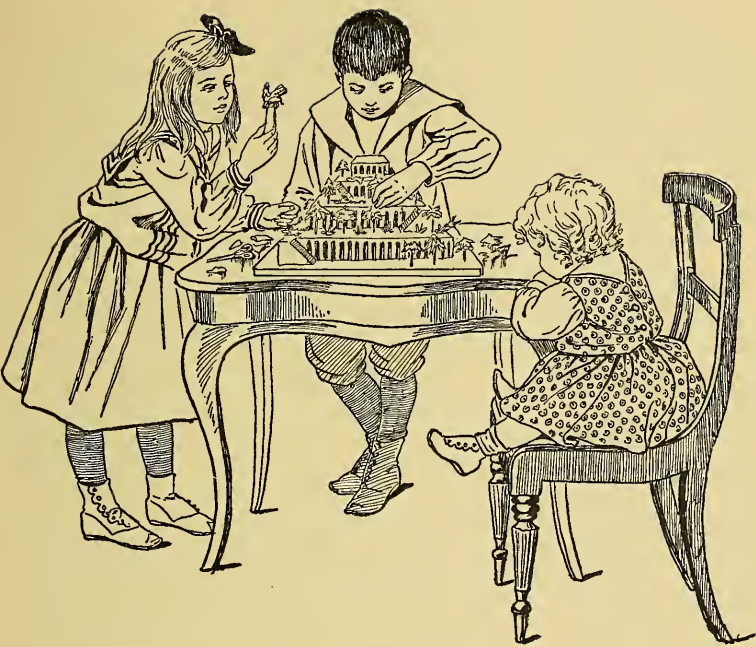

Fig. 376.—Your stairs will stand alone.

lines except that along the flap G at the bottom of the side which must be bent forward that it may lie flat on the ground. Open out the stairs flat and with pen and ink draw straight lines from side to side of C C; the lines will serve for steps. In like manner make lines on each of the three other flights of steps. Bend down the two flaps H and J on the top landing (Fig. 375),

then the line F E along one edge of the steps; turn outward the flap G, bend down the line F L at the head of the stairs, which will bring the flap J under the top of the side D F. Turn back the line



Making Our Hanging Garden.

D D that the back may cover the flap H. Crease down the flap K tight and flat; let its top M extend around and lie flat against the under side corner N of the flap H, and your flight of stairs will be able to stand alone (Fig. 376).

### **Gum the Extension**

of the top landing securely along the front edge of the extreme left-hand corner of the first story of your Gardens and fasten the flap G to the ground. Make three more flights of stairs in the same way, only let the second flight run in the opposite direction from the first, as shown in Fig. 377. To do this, simply bend the dotted lines forward instead of backward, except the lower flap at bottom of the side, which should be bent backward; this method of folding turns the stairs around, bringing the under side of the paper topmost after the stairs are bent into shape. Let the second flight of stairs measure in length from C to C (Fig. 375) three and one-half inches, in width seven-eighths of an inch, height from D to D two and one-half inches, length D E three and one-eighth inches, length of top of side D F three-quarters of an inch, height of back two and one-half inches, width of back seven-eighths of an inch; top landing, three-quarters of an inch by three-eighths of an inch.

Fasten the

### **Second Flight of Stairs**

at the right of the second story as you glued the first on the left hand of the first story. Crease the third stairway in the same way as the first, for it is to run in the same direction. Let these stairs measure in length from C to C (Fig. 375) two and seven-eighths inches, in width five-eighths of an inch, height from D to D two inches, length D E two and one-half inches, top of side D F half an inch, height of back two inches, width five-



eighths of an inch; the top landing one-half inch by one inch. Fasten this stairway at the left-hand corner of the third platform.

Make the fourth and last stairs turn in the same direction as the second. These are the smallest: Length from C to C (Fig. 375) one and three-quarters inches, width three-eighths of an inch, height from D to D one and one-quarter inch, length D E one and one-half inch, top of side D F one-quarter of an inch, width of back three-eighths of an inch, height of back one and one-quarter inch. Top of landing one-quarter of an inch by five-eighths of an inch. Bend into shape and glue this flight of steps at the right-hand corner of the top platform of the Gardens.

Now go to work on the

**Stone Broad-Fronted Bulls**

which are to stand in pairs at the landing of each stairway.

Make Fig. 378 of white paper and with ink draw the wings, face and hat like Fig. 379. Then cut out the strange animal, part bull, part bird, and part man. Bend at dotted line on top of wings (Fig. 378); bend outward all four



Fig. 378.—Cut out the stone bulls by this pattern.

of the extensions under the hoofs and stand the creature at the top of the first stairway. Paste the extensions out from the



Fig. 379.—The stone bull who will guard your stairway.

hoofs firmly to the platform. Carve or cut out seven more stone bulls and place two at the head of each stairway as in Fig. 377. Gum each stone bull securely in place. One more bull is needed which must stand up high on top of a stone shaft (Fig. 380). Height of shaft is three and one-fourth inches, not counting flaps or bull; width of same pattern at top fully two and one-half inches, width at bottom three and one-fourth inches. Height of bull from top

of wings to bottom of feet one and one-fourth inch. Mark and fold it along dotted lines like Fig. 381, sliding the two flaps P P (Fig. 380) through the slits Q Q; crease the flaps backward to form paper hooks that hold fast. Turn out the extensions R R, which must be pasted down flat near the right hand on the back part of the top of the third story. The shaft will extend up high above the fourth story, as in Fig. 377.

### Make Two Statues

a little larger than diagram and glue one at the right-hand corner of the front of the first platform, and the other on the right-hand corner of the back of the first platform as in Fig. 377. Use two pieces of white stiff writing paper for the two statues (Fig. 382). Cut all the heavy lines and bend back all the dotted lines

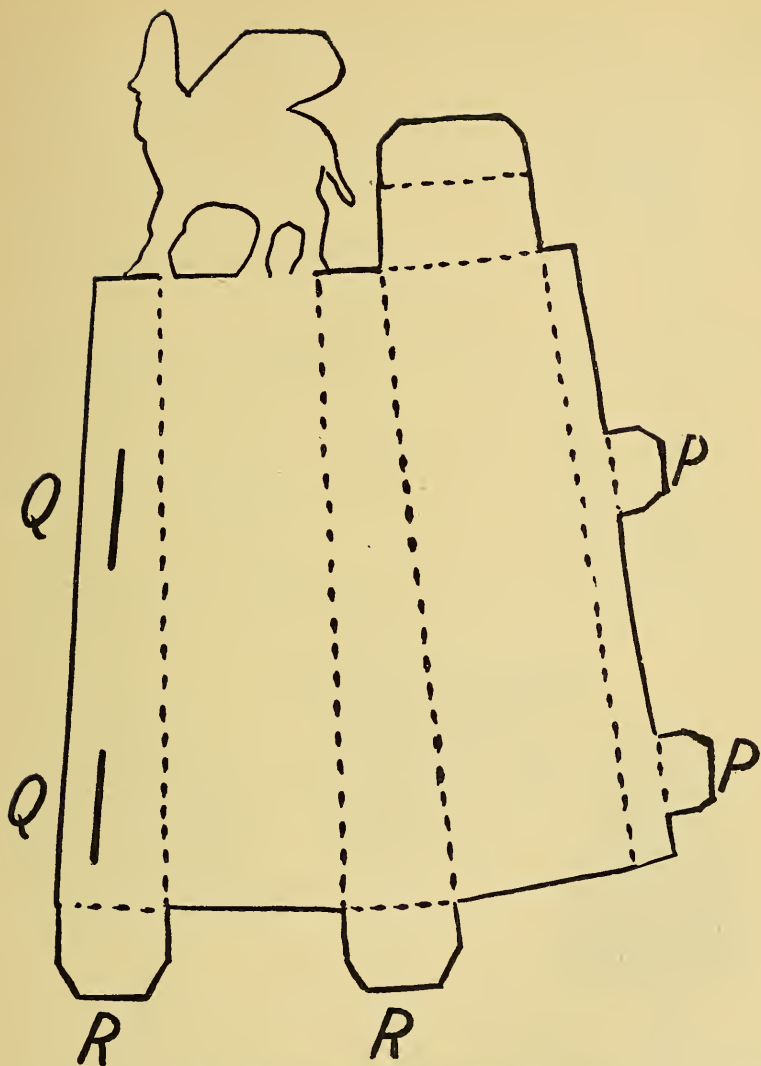

Fig. 380.—The bull on the shaft is made in this way.

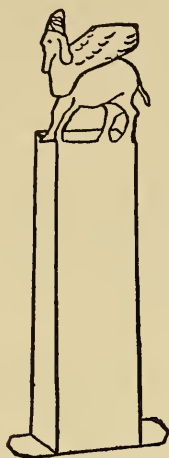

Fig. 381.—Stone shaft and bull.

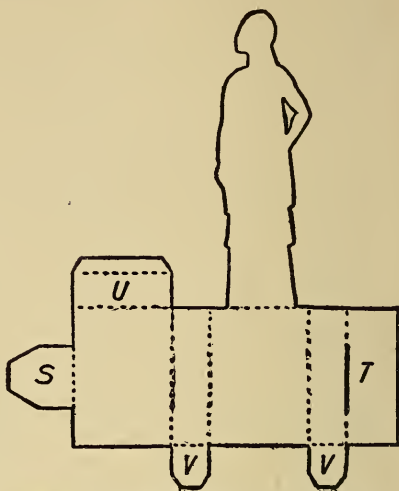

Fig. 382.—Use writing paper for the statues.



Fig. 383.—A tree in the garden of fringed paper.



Fig. 384.—A palm tree.



Fig. 385.—A tree in the garden.

except the extensions V V; bend these forward. Slip the flap S through the slit T; bend down and fit in the top U; then glue the statues in place. Color all of the white extensions of stairs, bulls, and statues with green paint or with green tissue paper pasted over them.

The Garden will now be ready for

### The Shrubbery

Use different tones of green tissue paper for the three varieties of trees (Figs. 383, 384, 385). Make several trees of each kind and have all of the same variety, made of one tone of paper. For Fig. 383 fringe the paper as in Fig. 386; have four layers of paper for the fringe and one layer for the unfringed part; begin with the plain strip and roll it around and around a slender stick (Fig. 386). Bend the top over to prevent its unrolling (Fig. 383).

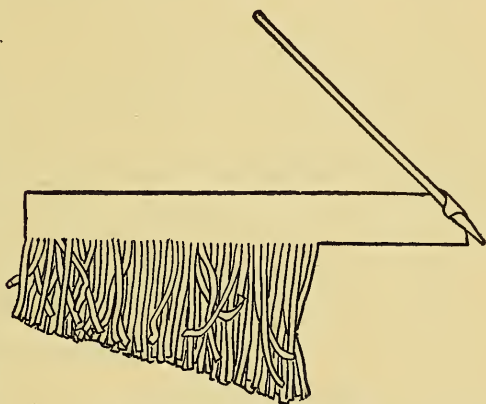

Fig. 386.—Make fringe like this.

### Plant This Tree

in the hole you dug for it on the first platform just back of the front statue (Fig. 377); alternate these trees with the palm trees, extending the line entirely around the top of the first platform of the Gardens. Fig. 387 gives the pattern for the palm; cut

the six leaves and strip all in one piece, fold each leaf lengthwise through the centre W, and fringe as in X; unfold the leaves and

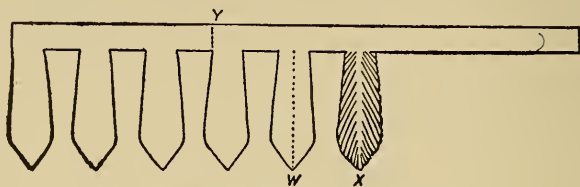

Fig. 387.—Pattern for the palm tree.

double the strip on dotted line Y and roll it on a slender round stick as you did the first tree.

For the other tree use six layers of fringe which you have cut like Fig. 386, and afterward crimped with a blade of the scissors. This time begin at the top of the stick instead of the bottom and with the narrow top of the fringe roll the paper down to the pointed end of the stick. This gives the tree a bushy foliage (Fig. 385).

Cut circles of dark olive-green paper to

### Make Plants

like Fig. 388. Fold the circle evenly four times and cut like Fig. 389, stopping at dotted line before reaching the centre.

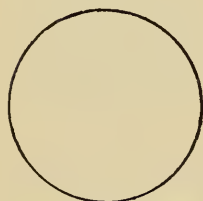

Fig. 388.—Cut circles of green paper.



Fig. 389.—Fold and cut like this.



Fig. 390.—The circle cut and opened.

Unfold and the papers will resemble Fig. 390. Hold each of these at the centre, and twist a few times to make the stems (Fig. 391). Plant the shrubs between the trees on top of the second platform. Cut a number of light sage-green tissue paper shapes like Fig.



Fig. 391.—A shrub for the garden.

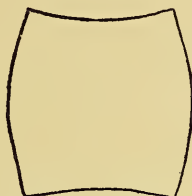

Fig. 392.—This is for a plant.



Fig. 393.—Twist the stem of the plant.

392 for plants. Holding each of the plants at the centre, crease by drawing it lightly through the fingers of the other hand, twist the stems (Fig. 393) and plant between trees.

### Arrange Your Plants

in precise formal rows, a tree then a plant, next a tree and so on allowing a tree in a higher platform to come between two plants in the platform beneath as in Fig. 394.



Fig. 394.—In formal rows.

Make vines of rather long, very finely cut and crimped tissue paper fringe; paste the vines between the row of trees on the first platform, allowing portions of the vine to hang over the edge. Make a number of palm trees and plant the roots or ends of the tree trunks in button moulds. Glue the moulds at equal distances apart and in a straight line along the ground on the three sides of the gardens.

Play that in the highest platform of the pyramid

#### **An Engine Pumps up the Water**

from the river Euphrates, that runs along below on one side of the structure, to supply the garden with fountains which you can make believe are sparkling and dashing here and there among rare shrubs and many-colored, fragrant flowers. You must pretend that the spaces between the arches on the different platforms are made into magnificent apartments and banquet rooms and below in the vaulted corridors the money changers and politicians ply their trades, while outside on the terraces are to be found the simple, sweet pleasures of wholesome Nature.



PART III

THINGS TO MAKE FOR HOME, GIFT DAYS,  
AND FAIRS



*Aelia B. Beard*

The Tissue Paper Christmas Greens Look Very Natural.

## CHAPTER XXV

### NEW CHRISTMAS DECORATIONS



REATHES of the spiked leaf holly, branches of white berried mistletoe and yards of evergreen rope can be made of tissue paper to look so natural it is difficult to believe Mother Nature did not provide the material.

#### Paper

enough for the making of Christmas greens to decorate an ordinary room quite lavishly may be bought for fifty cents or less. One sheet of tissue paper will make thirty-two holly leaves. One sheet of tissue paper will make a large bunch of mistletoe and one sheet of tissue paper will make one yard of evergreen rope. Complete success in this work depends largely upon the paper used and great care must be taken in selecting the colors. The quality should be good, else it will lack the necessary crispness and staying properties.

For the holly and evergreen choose a dark moss-green paper, which is a yellow green with no tinge of blue. For the mistletoe you must have a light gray-green, also of a yellow tone, a light cardinal red for the brilliant holly berries, white for the waxy mistletoe berries and dark gray-brown for holly stems. One

sheet each of the red and white paper will probably be sufficient for all the berries you will want, and one sheet of gray-brown will answer for the stems. Besides the paper you must have a spool of fine wire or coarse thread for winding and some natural bare branches or twigs, or a roll of heavy bonnet wire for stems.

Begin with the

### Holly

and cut one sheet of the dark moss-green tissue paper in half (Fig. 395). Fold the half sheet according to the dotted lines through the middle and you will have Fig. 396. Fold Fig. 396 through the middle as shown by the dotted line and there will be Fig. 397. Bring the two ends of Fig. 397 together, folding at the dotted line, and it will give you Fig. 398. Again fold along the dotted central line and you will have Fig. 399. Fold through the middle, along

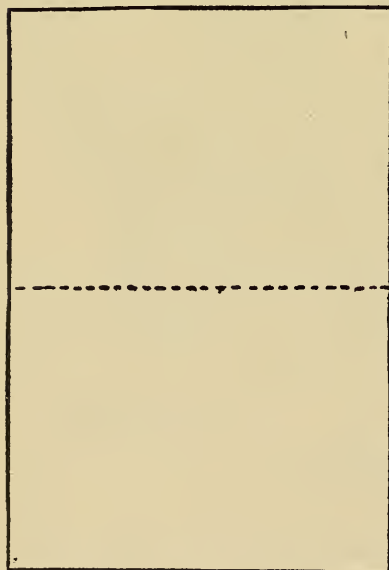

Fig. 395.—Cut a sheet of tissue paper in half.

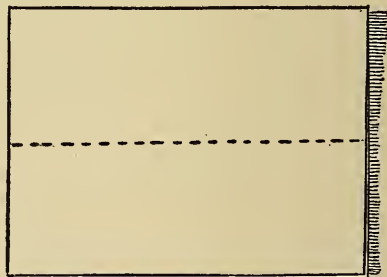

Fig. 396.—Fold the half sheet of paper.

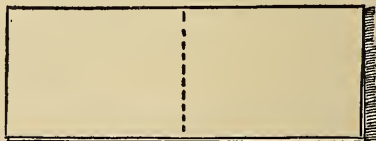

Fig. 397.—Fold again.

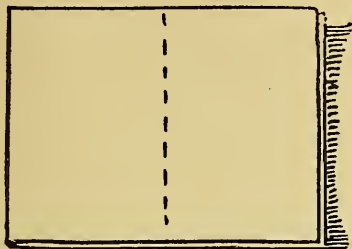

Fig. 398.—Bring the ends together.

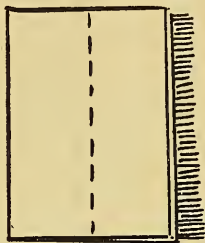

Fig. 399.—Fold once more.

the dotted line, for the last time and there will be an oblong, one and three-quarter inches wide by five inches long.

With a soft lead pencil draw the outline of a half holly leaf after the pattern (Fig. 400), the fold of the paper forming the straight edge of the outline. Cut along the pencil line, open the fold and there will be sixteen leaves like Fig. 401. The dotted line

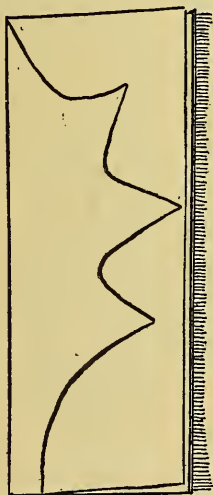

Fig. 400.—The paper is folded and leaf cut out like this.

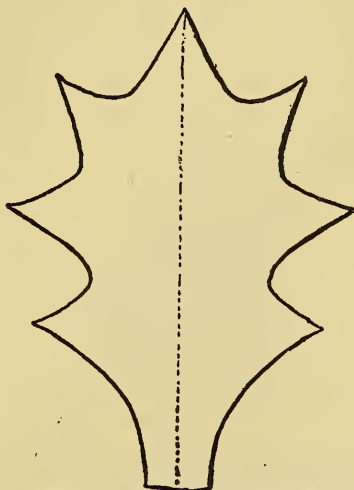

Fig. 401.—Sixteen leaves like this.

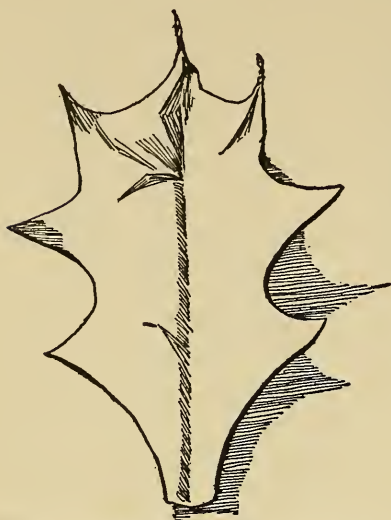

Fig. 402. — Begin at the top to twist the points.

(Fig. 403) and, refolding the leaf down the middle, pinch the underside of the fold to form the mid-rib, bringing your



Fig. 403.—Pinch the underside to form the mid-rib,

running lengthwise through the middle of the leaf shows where the paper was folded. Have a damp sponge ready and slightly moisten the fingers of your right hand on the sponge—never with your lips in handling green paper. Take one leaf in your left hand and with the moist fingers of your right hand twist each point of the leaf into a sharp spike, beginning at the top of the leaf as in Fig. 402. Twist the lower part of the leaf into a stem

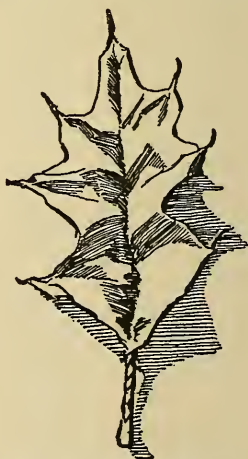

Fig. 404.—The finished leaf will look like this.

two hands together and puffing the paper a little as you do so (Fig. 403). The finished leaf should resemble Fig. 404. The crinkled appearance given by pinching and twisting adds much to the natural look of the leaf. You may vary the size, making some leaves smaller than others, but keep as nearly as possible to the pattern, for experiment has proved it to be a good one.

Before putting your leaves on the stems make the

### Holly Berries,

for they must be fastened on first.

From your red tissue paper cut a number of pieces two and a half inches square, make a little ball of raw cotton a trifle larger



Fig. 405.—Place the cotton in the centre of the paper.

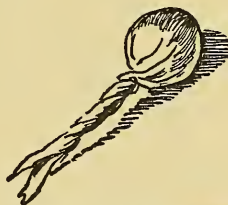

Fig. 406.—Draw the paper around the ball.



Fig. 407.—Wrap the three stems together.



Fig. 408.—Cut off the ragged ends.



Fig. 409.—Fasten the berries to the end of a twig.

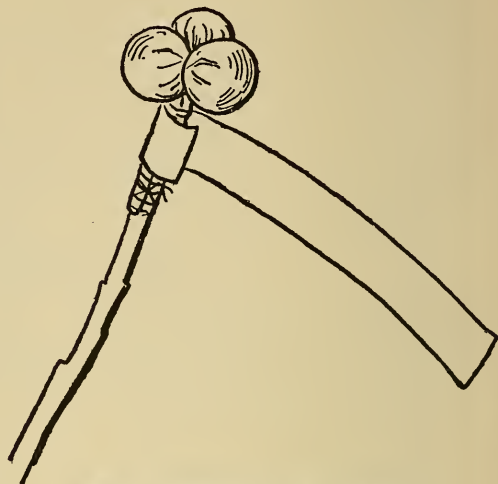

Fig. 410.—Beginning to wrap the stem.



Fig. 411.—The stem is wrapped with paper.



Fig. 412.—Fasten the leaves to the stem.



than a good sized pea and place it in the centre of one of the squares of paper (Fig. 405). Draw the paper up and around the ball, completely covering it, then twist the remainder of the paper into a stem (Fig. 406). Make three berries, twisting their

stems as tightly as possible and bunch them. With your fine wire or thread, wrap the three stems closely together (Fig. 407) and cut off the ragged ends (Fig. 408).

Take up a natural branch and wrap the stems of the berries to the end of a twig (Fig. 409). Cut a strip of the gray-brown paper half an inch wide and about four inches long, and, beginning close to the berries

(Fig. 410), wrap the stem with the paper as shown in Fig. 411.

Fasten three leaves

to the stem close to the berries as in Fig. 412, and place other leaves about one inch apart, alternating first on one side then on the other side of the stem (Fig. 413).

When the holly is to be made into



Fig. 413.—Place the other leaves about one inch apart.

to the stem close to the berries as in Fig. 412, and place other leaves about one inch apart, alternating first on one side then on the other side of the stem (Fig. 413).

When the holly is to be made into

### Wreaths,

the branches should not be large and a small wooden or wire hoop should form the foundation of the wreath. Upon this hoop the small branches of holly must be bound, overlapping one another and extending out beyond the hoop to form a generous wreath. A bright red ribbon bow, fastened at the top of the holly wreath, gives it a still more realistic effect.

### For Mistletoe

cut the gray-green tissue paper into pieces eight and one-half inches long by one and a half inches wide. Bring the two ends of a strip together, folding through the middle, to form the oblong

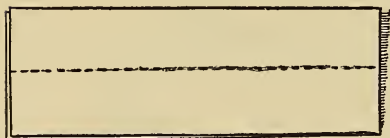

Fig. 414.—Bring the two ends of the strip together.

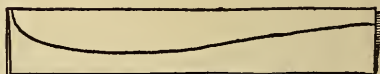

Fig. 415—Cut out the mistletoe leaf in this way.

(Fig. 414). Fold Fig. 414 lengthwise through the middle along the dotted line and on it draw the outline of half of a mistletoe leaf, with the straight edge on the long fold and the stem end on

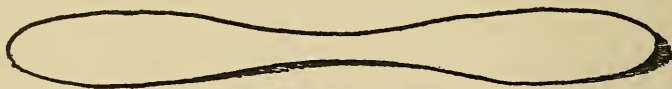

Fig. 416.—The twin leaves.

the short fold of the paper (Fig. 415). Cut along this outline, open the folds and you will have twin leaves like Fig. 416. Bring the two open leaves together and twist the connecting part into



Fig. 417.—Twist the connecting part into a stem.



Fig. 418.—Nestle a couple of berries in between two leaves.

a stem like Fig. 417. Make a number of white mistletoe berries according to the directions given for the red holly berries and wrap them together in pairs; then nestling a couple close in between two leaves (Fig. 418) wrap them on the stem. The

### Stems

of the mistletoe should be very irregular and branching, and it may be necessary to make them of bonnet wire in order to produce the proper shape.

Fig. 419 shows the branching irregular stem and the position of leaves and berries. Some of the twigs should be left bare, as they are so often on the natural mistletoe branch.

Fasten on the leaves and berries by wrapping with fine wire and then cover the stems with strips of the gray-green tissue paper, wrapping it as directed in making the holly branch. The only difference being that while the holly stem is wrapped with paper only far enough to cover the red stems of the berries and the leaves are put on afterwards, the mistletoe leaves must be

fastened on with the berries and the entire stem then covered with the paper. You will remember that the stems of the natural

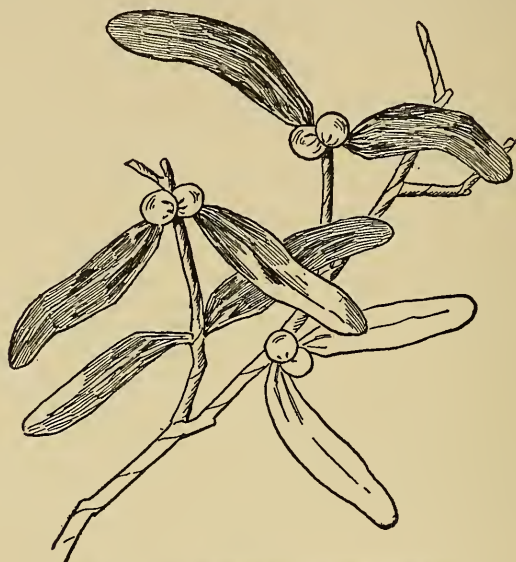

Fig. 419.—Put the leaves and berries on the stem.

mistletoe are as pale in color as the leaves, so no dark wood must show in your branch.

Hang your bunch of mistletoe from the chandelier and you will find that no one will stop to examine it too closely, and the Christmas games can be played just as merrily under the paper as under the real mistletoe.

There now remains but the

### Ropes of Evergreen

to complete the time-honored Christmas decorations.

Fold a sheet of the dark moss-green tissue paper crosswise, then fold again and you will have an oblong a little less than four

inches wide and the length of the paper's width. Press the folds down flat and cut them open with a paper knife, then, keeping the strips together, fold crosswise through the middle; again

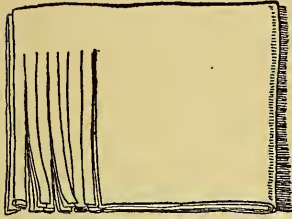

Fig. 420.—Cut this oblong into a fringe.



Fig. 421.—Begin the evergreen rope in this way.

fold crosswise through the middle and there will be an oblong like Fig. 420. Cut this oblong into a fringe, bringing the slits to within one inch of the top edge and making each strip not more than one-quarter of an inch wide (Fig. 420). Unfold and

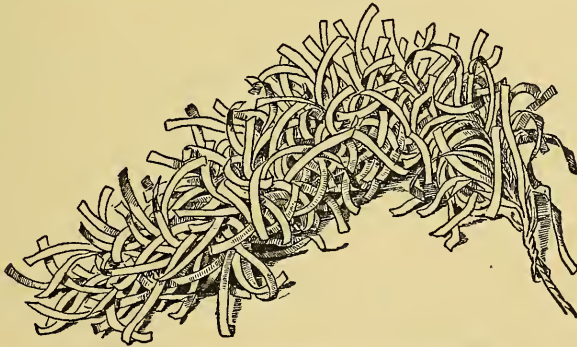

Fig. 422.—The evergreen rope is made like this.

separate four pieces to loosen the fringe, then place the top edges of the four pieces together once more and, taking a long piece of strong twine, curl the right hand upper corner of the heading of

the fringe over the twine near the end (Fig. 421). From this start to wrap the fringe around and around the twine forming the rope shown in Fig. 422.

When you have almost reached the ends of the first four strips of fringe, paste the ends of the headings of four more strips on to the first and continue to wrap as before. In this way you may make your evergreen rope as long as you wish.

There is just one word of caution which must go with the assurance of the real beauty of these Christmas decorations and that is: Remember to hang your wreaths and ropes where they will not be exposed to the flames of gas, candle or lamp, for while they are scarcely more inflammable than the natural greens, it is not well to take any risks and neither is it at all necessary. With this in mind your rooms may be inexpensively, prettily and safely decorated with the tissue paper Christmas greens.

## CHAPTER XXVI

### DOLL HOUSE OF PASTEBOARD



COUNTRY houses are very attractive, even the toy ones possess a certain charm. Here is a great, big, beautiful, country doll house for the doll people to live in. It has window shutters to open and close, doors that will open and shut, and the doors have little door knobs like real ones. Each room has a different, colored frieze around the walls, and the floor of the living-room is covered with a handsome rug. All the windows are curtained, and the house is ready to furnish. You can make any and all kinds of furniture with empty spools of different sizes and pieces of pasteboard cut in various ways. As a hint, just to show how easily the furniture is made, glue a round piece of pasteboard on top of

#### A Large Spool

and you will have a pretty little table; paint it a red brown to resemble mahogany. If you need more suggestions, spool furniture may be found in "What a Girl Can Make and Do."

To make the doll house. Get three stiff pasteboard boxes about fourteen inches long, thirteen inches wide and six and

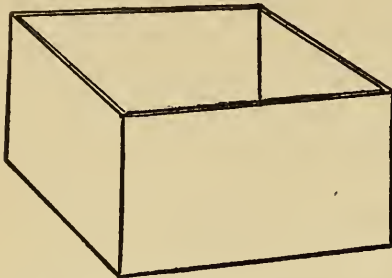

Fig. 423.—First pasteboard box for doll house.

draw two straight lines across the front on the inside of the box; let each line be about one and one-fourth inch from the side. Keep the box as it is while you score the lines with a sharp penknife; then cut out the front, leaving the upright pieces to form the corners at each end (Fig. 425). Cut the thirteen-inch front and left-hand side from the third box (Fig. 426). Mark two

one-half inches high (Fig. 423). Cut the thirteen-inch front and the right-hand side from the first box (Fig. 424). Take the second box and lay the fourteen-inch front down flat on top of an old, common wooden table which can be used without fear of injury, and with the aid of a ruler,

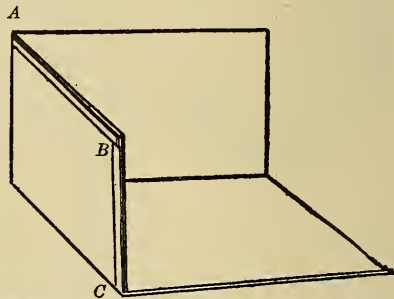

Fig. 424.—Front and right-hand side cut from box.

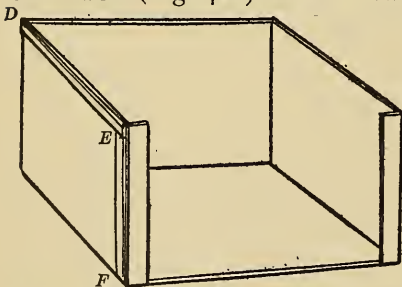

Fig. 425.—Second box with corners left on front.

high windows (Fig. 427) on the inside, near the front of the left side of the first box (Fig. 424). Make each window two and one-half inches high and two and one-half inches wide, leaving a space of three-fourths of an inch between them. Lay this left side of the box flat down on the table



and use the sharp penknife to score the dotted lines and cut the heavy lines. Always cut and score from the inside of the box, otherwise the shutters will turn inward.

When the window is scored and cut, throw

### Open the Shutters

and look out through the little opening of the doll's kitchen window (Fig. 428).

In the second box (Fig. 425) cut a door five and one-half inches high and three inches wide through the left side wall, one and three-fourths of an inch from the back wall. The

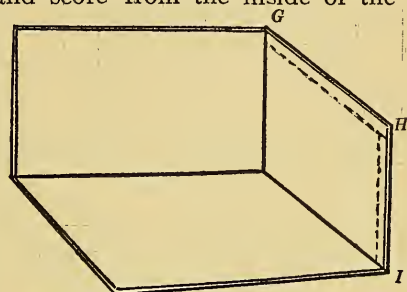

Fig. 426.—Third box with front and left-hand side cut off.

two high windows, each two and one-fourth inches wide and two inches high and the one ordinary large window, four inches high and two and one-fourth inches wide, must be marked on the back wall

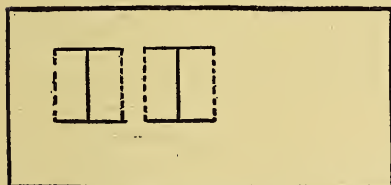

Fig. 427.—Two high windows marked in left wall of first box.

(Fig. 429) and cut (Fig. 430). Cut another door in the room through the right-hand side wall near the front (Fig. 431) and bend it wide open (Fig. 432).

### Make Doorknobs

of large-sized beads; and fasten one on each side of both doors with a strong, heavy piece of broom-straw run through and

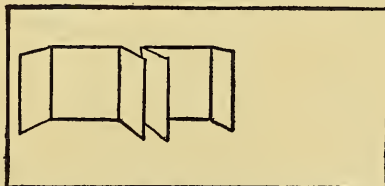

Fig. 428.—Look through the open windows.

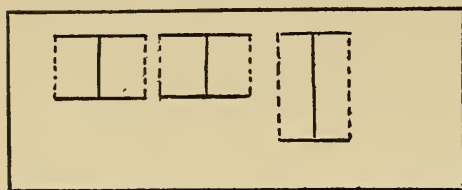

Fig. 429.—Two high and one ordinary window in back wall of second box.

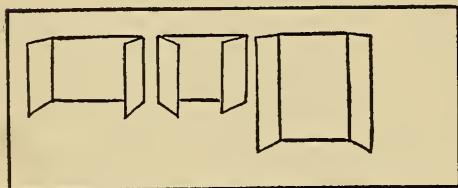

Fig. 430.—Windows in second box opened.

426) cut a large window through the back wall four and one-half inches high and three and one-fourth inches wide. Fig. 433 shows this window in detail with one shutter open and one closed.

Excellent

### Window Glass Can Be Made

of white tissue paper cut to fit the various windows, allowing one-fourth of an inch extension on all four sides. Immerse the paper thoroughly on both sides in oil; with a dry, clean cloth wipe off the oil; again immerse the

glued in a hole punctured through the door with a coarse darning needle or hatpin. Slide a bead on each end of the broom-straw and glue them securely in place. Strengthen the hinges of each door with a narrow strip of thin white cotton cloth pasted lengthwise on the open door, half on the door and half on the wall.

In the third box (Fig.

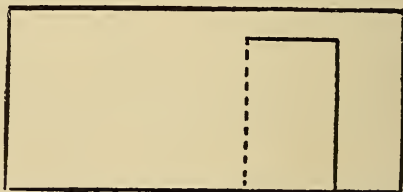

Fig. 431.—Door in right-hand wall of second box.

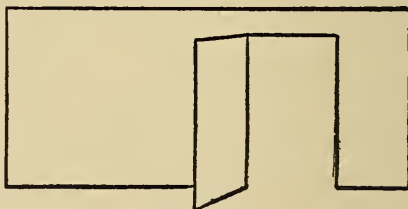

Fig. 432.—Door opened.

papers, let them remain in the oil for some minutes and a second time wipe the oil from both sides of each paper. This makes the paper almost transparent.

The window frame or sash, is made of strips of black or inked paper, one long, narrow strip pasted down the entire centre length of each window glass and a wider strip fastened across the first strip at the centre, from side to side of the glass (Fig. 434). Keep the glass and the sash divisions perfectly smooth while fastening them together.

When all are ready, close the shutters of each room in turn, and place first one and then another side flat down on top of the table and brush a little glue all around the edges of the window opening (Fig. 435); lay the glass over the opening, making sure that the edges of the glass extend evenly out on the wall surface from all sides. Do not rub the glass, press it tightly down with a dry cloth.

After the windows have been glazed cut strips of fresh, smooth, ordinary wrapping-paper, not less than one-fourth of an inch

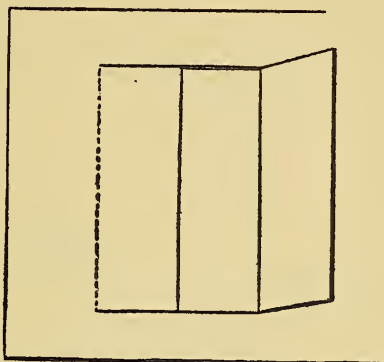

Fig. 433.—Window in detail with one shutter open and the other closed.

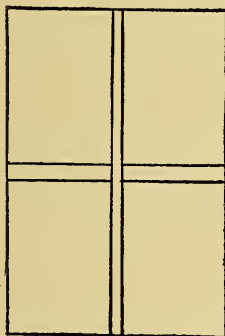

Fig. 434.—Window glass.



Fig. 435.—Opening of window ready for glue.

wide, and cover the edges of each window glass with the strips, paste them on straight and even to form woodwork around the window as well as to cover the edges of the glass (Fig. 436).

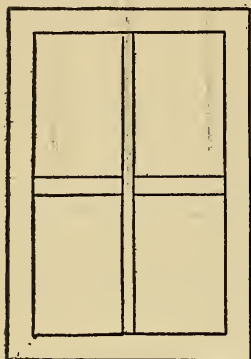

Fig. 436.—Paper wood work window frame.

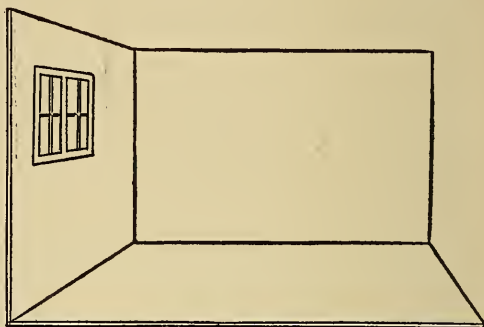

Fig. 437.—Kitchen.

Fit the second box (Fig. 425) in the first one (Fig. 424), mark and cut off the portion of the first box (Fig. 424) extending beyond the front of Fig. 425; do the same with the third box (Fig. 426), that

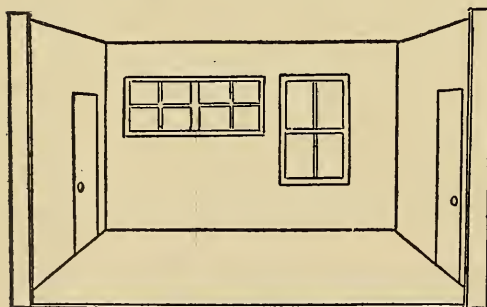

Fig. 438.—The living-room.

all three boxes may be of equal depth, and when fastened together the long front line may be straight and even.

**If You Want the Doll House to Last for Years,**

reinforce the building with strips of wood (A B C, Fig. 424; D E F, Fig. 425; G H I, Fig. 426). Where any two strips meet, glue the ends together

and fasten to the pasteboard walls. If you cannot obtain very thin strips of wood, use strips of pasteboard as stiff as wood.

Be sure that your flour paste has boiled well and is strong and thick, for fastening

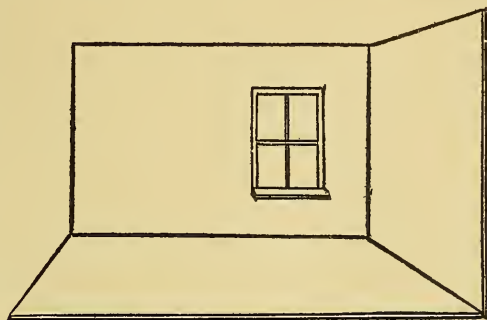

Fig. 439.—The bedroom.

the three rooms together. Give the kitchen (Fig. 437) a generous layer of paste down the inside edge of the back wall and along the edge of the floor at the open side; then fit the left-hand edge of the floor and back wall of the living-room (Fig. 438) over the paste and press it firmly in place. Fasten the bedroom (Fig. 439) on the right-hand side of Fig. 438 in the same manner.

Close the little shutters and

### Place the Doll House on the Floor

of a real room, tight up against the wall; then put weights along on the inside edges of the floor of the toy living-room and pile books up close against the back wall; at the same time do not press the side walls out of plumb; keep them straight.



Fig. 440.—The bottom of the house is like this.

When the house is perfectly dry, tack one thin strip of wood across the entire length of the top of the back wall of the house from end to end. You can manage

this very readily by turning the house and laying the back wall flat on the table, the top edge of the wall barely covering the strip of wood; then you can tack at long intervals from the inside of the wall and fasten the pasteboard walls to the wood. Be sure to glue the ends of the side wall strips securely to the back wall strip.

Set the house upright in proper position and tack thin strips of wood along the under edge of the bottom of the house. Fit one strip under the house at a time and tack from the inside of the house through the pasteboard floor into the wood. Make the ends of the upright side wall strips fast to the under-floor strip. When finished, the bottom of the house should resemble Fig. 440.

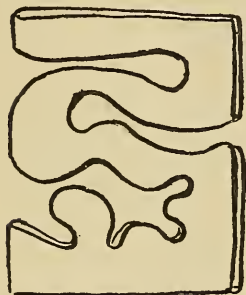

Fig. 441.—Cut the paper like this for the frieze.

#### Make the Frieze

for every room of three strips of tissue paper cut five-eighths of an inch wide. Fold each separate strip crosswise through the centre; again fold through the centre, and fold a third time, making eight layers of paper. Cut the folded strip like Fig. 441, unfold, and you will have Fig. 442. Try for a different pattern in each room, and let the colors vary. A soft yellow for kitchen, sage green for living-room, and a light, warm yellow pink for bedroom are a pleasing variety.

Brush a thin layer of paste the width of the frieze along the

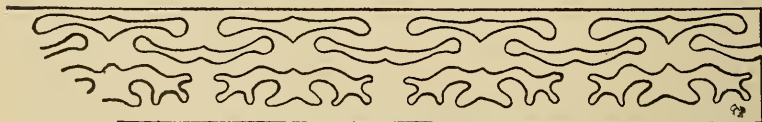

Fig. 442.—Frieze opened out.

top edge of the walls of the kitchen (Fig. 424) and fasten on the yellow frieze. Do the same with the living-room, fastening on the green frieze (Fig. 425), and in the bedroom the pink frieze (Fig. 426).

### Cut a Rug for the Living-Room

from sage-green tissue paper; make it ten inches long and seven and one-half inches wide. Fold the paper lengthwise through the centre, then crosswise through the centre, and a second time crosswise, making eight layers. Cut according to Fig. 443, unfold once (Fig. 444), and cut the designs K and N; fold diagonally the loose corners L according to dotted line and cut design M (Fig. 445). Open out the rug (Fig. 446).



Fig. 443.—Cut through all layers of rug.

Cover the required space on the living-room floor with a thin layer of paste, place the rug down over it, using both hands, to avoid wrinkles.

With the same kind of wrapping-paper used for the wood-work you can make projecting window-sills. Fold and crease



Fig. 444.—Cut out designs K and N.

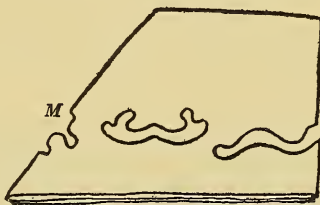

Fig. 445.—Cut out design M.

the paper into a narrow box-lid long enough to extend across the window, including the woodwork; glue one of the lengthwise turned-down edges on the wall below the window glass.

Make three

### Shelves for Books,

with the ends of the shelves turned up to hold the books in place. Fasten the lengthwise turned-down edge of the first shelf on the

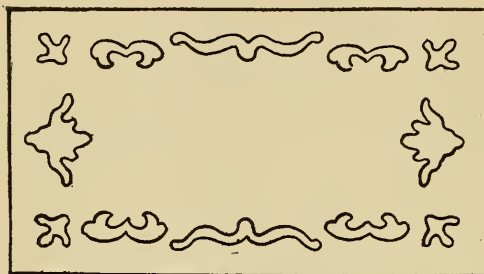

Fig. 446.—The rug for the living-room.

wall three-quarters of an inch below the high window in the living-room, and paste the other two shelves below at short distances apart.

You can easily make tiny books of several pieces of folded

paper cut the desired size and sewed together through the centre fold. Hang red

### Tissue Paper Curtains

in the living-room, white tissue-paper curtains in the bedroom, and yellow ones in the kitchen, as seen in Fig. 447.

Little shelves over the tops of the doors may be made in like manner, also a cunning little three-cornered bracket to fit the

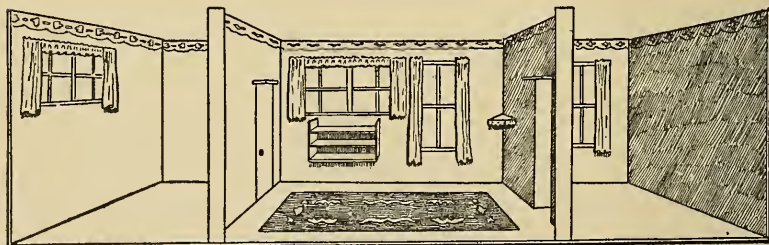

Fig. 447.—House ready for spool furniture.



---

corner of the room for holding a tiny Japanese vase of satiny yellow ware, the straight up-and-down kind, made of a three-fourth-inch length section of common straw pasted on a wee round disk of paper. Fill the vase with tiny red paper flowers fastened on broom-straws.

## CHAPTER XXVII

### THE MAKING OF A BAYBERRY CANDLE



ROWING wild all along our eastern coast from Nova Scotia to Florida is the bayberry-bush, once well known and valued, now overlooked and almost forgotten, although a wealth of sweet smelling wax is held in its tiny berries.

A quart of bayberries, a little time, a little trouble, and we have a beautiful green wax candle, hard, brittle and smooth, that hot weather will not melt and whose expiring flame yields an incense sweet and aromatic.

There is a peculiar joy in using the raw material fresh from Mother Nature's hands and starting at the beginning of things—a joy unknown to those who work only with materials that are manufactured—and to get the most out of the work of making bayberry candles you must begin with the bayberries.

First locate your

#### **Bayberry-Bushes;**

then, just the time when out-of-door exercise begins to be a delight, the latter part of September or early in October, gather the berries and take them home for future use.

The bayberries, which seem to be nothing but tiny stones covered with a coating of wax, do not decay quickly, but shrivel up into small gray pellets that will keep, it is said, a year or more.



*Aelia B. Beard*

The Fragrance of the Steaming Payberry Fills the House.



Look for a bush that is stiff and irregular, generally growing low in closely crowded patches like the blueberry, though at times reaching the height of eight feet. It appears to thrive best and is most often seen in sandy soil, but it will grow in almost any kind and flourish even amid the rocks on a barren hillside.

### The Leaves

are oblong and from two to three and a half inches in length (Fig. 448). They usually have several teeth, or notches, near



Fig. 448.—The bayberry leaf looks like this.

the tip and are quite narrow at the base. Sometimes they are scattered and again in close bunches. The young leaves are a pale green frequently tinged with red; when matured they are a bright green, glossy, and of a leathery texture and they are very fragrant when crushed in the hands. The bark is brownish gray and the young stems light, or golden brown.

### The Berries

are quite small and grow in thick clusters on short stems. Fig. 449 gives the berries, drawn from nature and of actual size. They are green at first, but, when ripe, turn a light silvery gray. As it will take about one quart of berries to make one candle you may adapt your picking to the number of candles you want.

Keep the berries in a dry place until

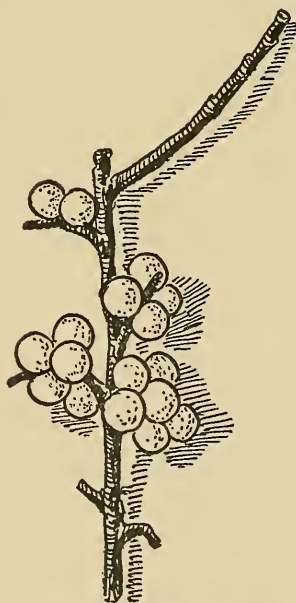

Fig. 449.—These are the bayberries, actual size.

**You are Ready to Make your Candles,** then into a six-quart preserve-kettle pour three quarts of berries and fill to the brim with cold water. This allows two quarts of water to one quart of berries. Put the kettle on the range and let it boil steadily four hours—actually boil, remember—and whenever the water gets three inches below the brim fill it up with hot water. The boiling berries will perfume the house with a spicy balsamic odor that is delightful. When the four hours

are up set the kettle back and let the berries simmer for an hour or two, then farther back where it will simply keep hot. At night take them off the range and set away to cool without removing them from the kettle. The cooling down from the boiling point to the point where the wax begins to form should be very gradual to obtain the best results, therefore the simmering and keeping hot after boiling.

Having put the berries away for the night, try to forget them, and do not be tempted to disturb the wax as it forms and floats in little cakes on top of the water, for breaking through the gathering crust will cause much of the wax to sink and cling to the berries beneath. When left undisturbed until morning, the wax forms into a large cake, hard and ready to be lifted out.

### **The Bayberry Wax**

is never, at first, free from impurities, such as bits of dried leaves, stems and occasionally whole berries, and it must be strained. Break up the wax and put it in a porcelain-lined, shallow saucepan and set it on the range where it will melt slowly; then strain through a fine wire strainer into a shallow bowl or soup-plate. Let the wax become quite cold and hard, melt and strain again, this time through a piece of cheese-cloth or fine sheer lawn.

So much for the bayberry wax. But there must also be

### **Candle-Moulds**

for making bayberry candles, and not many of us possess these old-fashioned treasures. Even if you happen to be one of the fortunate few, you will find it takes a great deal of the precious wax to fill these old moulds, and the candles made in them are really larger than you need; so the home-made candle-moulds will be best in any case.

From a sheet of legal-cap writing-paper cut a strip eleven and a half inches long and four inches wide (Fig. 450). Take an ordinary adamantine half candle, which is neither tallow nor wax, and, placing the paper on the table, short edge toward you, lay the candle down on it and bring the edge of the paper over the candle, as in Fig. 451. Press the paper down firmly and roll the candle away from you, in

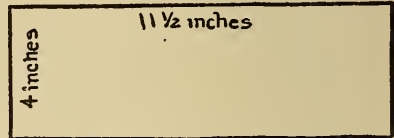

Fig. 450.—Cut a strip of paper.

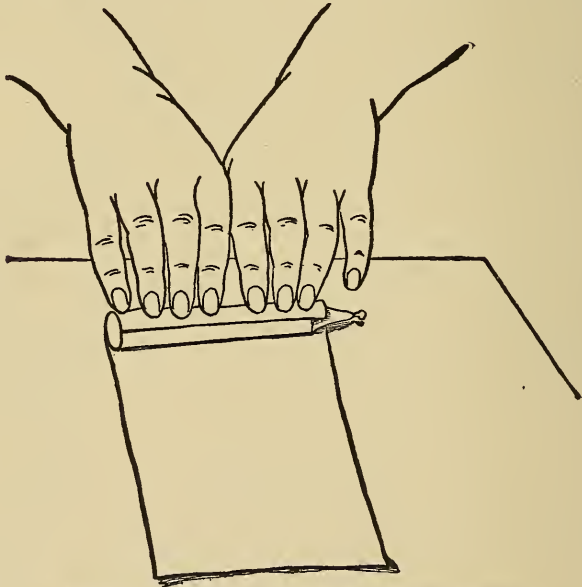

Fig. 451.—Bring the edge of the paper over the candle.

this way wrapping the paper closely around it. If the edges are not even, unwrap and try again. To have a perfect mould



you must keep one edge of the paper exactly on a line with the bottom edge of the candle. When the paper is wrapped around the candle to within one inch of the end of the paper, brush glue across the end of the paper as in Fig. 452. Bring the edge over the roll and press down (Fig. 453).

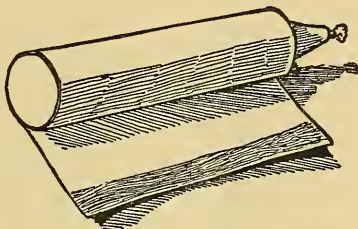

Fig. 452.—Pass a brush dipped in strong glue over the end.

Take another candle of the same size, stand it on a piece of paper and, with a lead-pencil, draw around the bottom edge, pressing the pencil point close to the candle. Cut around the circle you have made, leaving a border on its edge half an inch wide, as in Fig. 454, and slash the border up to the inner circle, as in Fig. 455.



Fig. 453.—Bring the edge over and press down.



Fig. 454.—Leave a border on the edge of the circle.

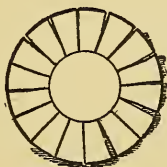

Fig. 455.—Slash the circle.



Fig. 456.—Lap them in regular order.

Draw another circle, this time using the roll with the candle in it to mark the size, and cut around it, leaving a border three-quarters of an inch wide, then slash the border as you did the first. Cover the laps of Fig. 455 with glue, set the roll containing the candle exactly within the penciled circle, and turn up the laps, one at a time, lapping them over one another in regular order, as in Fig. 456. Hold the laps in place until they are firmly glued to the roll, then make a dot with your pencil on the bottom exactly in the centre of the circle, and lay the roll aside for the glue to harden while you prepare

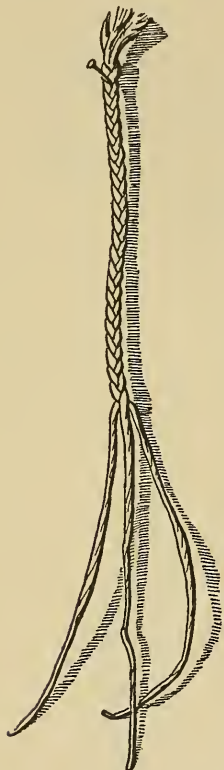

Fig. 457.—Braid the wick.

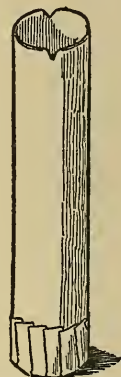

Fig. 458.—Cut two notches in the top.

### The Candlewicks

Candlewick comes in balls. It is composed of cotton strands which must be braided to make a finished wick. Cut from the wick several pieces nine inches long, select three strands for each candle, tie them together in bunches of threes, and braid, as shown in Fig. 457.

Take the candle from the roll, and in the top edge of the roll cut two notches directly opposite each other (Fig. 458), then melt the candle and pour it while hot into the mould, emptying it again directly. This will give the inside a coating of

wax which will keep the paper from absorbing the bayberry wax.

Puncture a small hole through the dot in the bottom of the mould and, after waxing the end to stiffen it, thread one of the wicks through the hole from the outside. Cut off the knot and draw the wick up to within half an inch of the end, then separate the strands, spread them out flat and glue them to the bottom (Fig. 459). Glue the last disk you made, over the wick on the

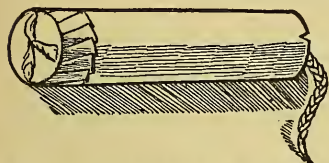

Fig. 459.—Glue the wick to the bottom.

bottom of the mould, arranging the laps in order as you did those of the first. Be very careful that none of the slashes run even the shortest distance across the bottom, and do not use the moulds until the glue is perfectly hard.

You will need a separate mould for each candle, and when all are ready

### Make a Stand of a Box

In the bottom of the box, cut three round holes just large enough to admit the candle-moulds (Fig. 460). Set the box in a small meat-platter to catch any spilled wax, and slip three moulds into the holes, allowing them to stand on the plate. Draw the wick of each up tightly and run a long hat pin through all three, resting the pin in the notches at the top and bringing each wick in the middle of its mould (Fig. 461). If this is done properly the wicks will not sag, but will be held taut by the pin.



Fig. 460.—Cut three holes in the box.

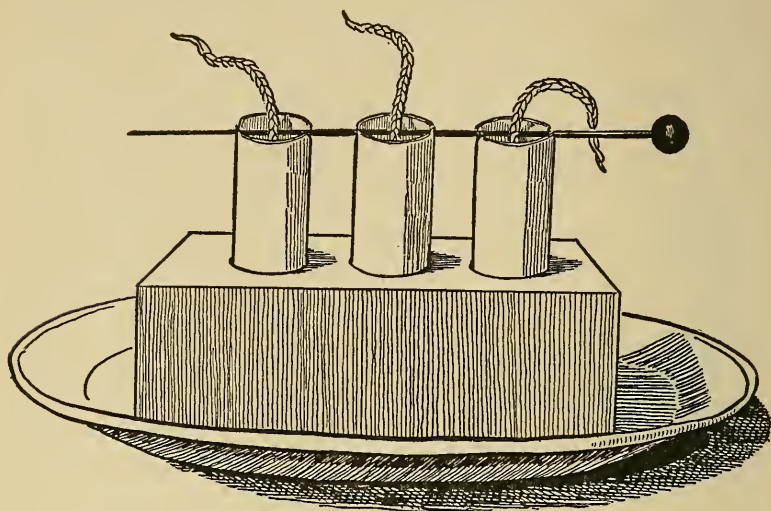

Fig. 461.—Run a hat pin through the wick.

Break up and

### Melt the Bayberry Wax

slowly, never allowing it to get hot enough to smoke, and fill each mould up to the hat pin. In a short time the wax will settle and leave a hollow at the top of the candle. Fill up the hollow each time this occurs until the wax remains even across the top.

Leave the candles in their moulds until they are hard and almost, but not quite cold, then draw the hat pin from the wicks and, taking one mould, begin at the top and peel off the

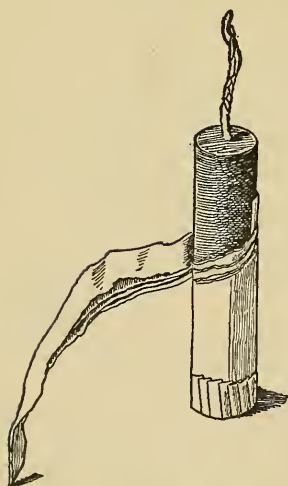

Fig. 462.—Peel off the paper.

paper, carrying it around and around spirally, as in Fig. 462. Insert the blade of a penknife between the bottom of the candle and the bottom of the mould, and cut around the edge. Remove first one layer of the bottom, then the other layer, after which you can draw the candle from the remainder of the mould.

Cut the bottom end of the wick close to the candle, and also trim off the top of the wick, making it about one inch long above the candle (Fig. 463).



Fig. 463.—The bayberry candle is finished.

## CHAPTER XXVIII

### WATER TOYS—LITTLE WAX PEOPLE THAT SWIM AND RIDE ON RAFTS



THESE little wax people are very fond of the water; in fact they are more at home and far happier in the water than when on land. Some of the wax girls and boys will be content to sit on the edge of the shore with their feet in the water; others will cling with both hands to the life-rope and dance up and down as the little waves dash upon them, though you will find that the more daring ones are not satisfied with jumping, but will often turn completely over while still grasping the rope.

#### The Patterns for the Little People

are given in Figs. 464, 466, 477 and 480. Cut ten girls from ten pieces of folded white writing-paper after first tracing the lengthwise half of Fig. 464 on half of the paper (Fig. 465). Cut ten boys (Fig. 466) from white writing-paper (Fig. 467). Paint each girl's hair a different color, varying from light brown to raven black, from golden blond to dark auburn. Paint their

bathing dresses red, blue, pink, orange, brown, green, yellow, purple, striped red and white, and spotted blue and white. Paint the boys' bathing suits in a similar manner; mark the features of

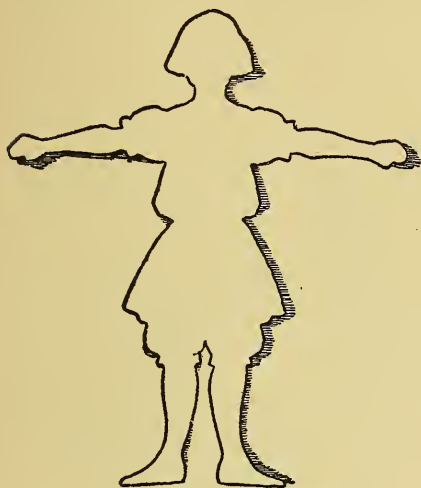

Fig. 464.—The girl bather.



Fig. 465.—This is the way to cut out the girl.

both girls and boys in ink, then color face, hands, arms, legs and feet pink. Use water-colors, and paint the back as well as the front of the dolls. When the paint is dry, take two girls and two boys and bend their arms forward at the shoulders; bend several dolls in a sitting position; take others and bend one leg forward and one backward, as if they were walking, and bend the hands together in front on those you wish to dive into the water from a height.

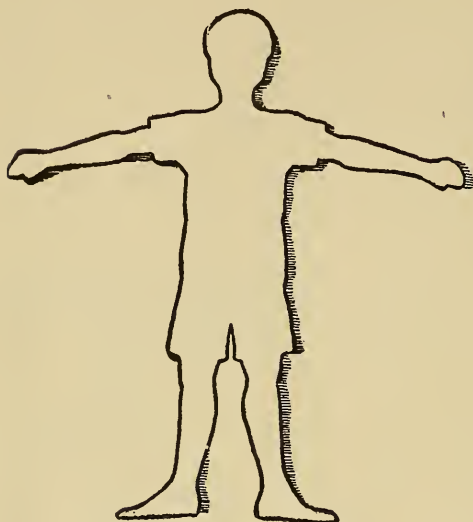

Fig. 466.—The boy bather.



Fig. 467.—The paper is folded for cutting out the boy.

When all are ready,

### Dip Each Doll in Melted Wax

One-half a wax-candle will be sufficient for the work. Be sure that each doll is completely covered on both sides with wax, and instead of paper dolls you will have twenty funny little wax dolls, the coloring showing distinctly through the wax. With a coarse needle and thread make

### A Toy Life Rope

and string on the thread four dolls with arms bent forward—a boy, a girl, a boy and a girl—by piercing the hands of each with the needle and drawing the thread through. In this way they are made to hold on to the thread rope.



Choose a clear, shallow pool or the edge of a pond for

### The Bathing Place

Tie the thread to a stick, the lower end of which must be fastened securely in the ground under water while its top end stands out above the water. Hold the loose end of the thread taut in one hand as you carefully slide the bathers along the life rope until



Fig. 468.—The bathers are having fun.

all stand in shallow water. The life rope reaches from the land out into the water. Stir the water and cause the waves to rise while you keep the thread moving up and down to make the dolls jump and frolic like real bathers (Fig. 468).

### For the Raft

make fifteen paper lighters of strips of writing paper nine inches long and three-quarters of an inch wide (Fig. 469). Begin at

one corner and roll the paper into a long round stick; fold over the top to keep the lighter from unrolling (Fig. 470). Dip each



Fig. 469.—This strip is for the lighter.

lighter in melted wax until it is completely coated all over; then wax two pieces of common string, each one a generous half yard in length. Tie or cross the centre of each string on a waxed lighter one inch from each end. Lay this lighter on a table in front of and parallel to you; place another lighter up against the ties, allowing one string from each tie to come over and one under the second lighter (Fig. 471). Cross the two lengths of each string over the last lighter, bringing the lower string up and the upper string down (Fig. 472); then lay another lighter up against the crossed strings, carrying the strings in turn over this lighter (Fig. 473). Again bring the lower string up and the upper string down before placing in another lighter, and always alternate the large and small ends of the lighters as in Fig. 474 in order to



Fig. 470.—A lighter for the raft.

have them equally balanced and to avoid bring-

ing all the small ends on one side and the large ends on the other side of the raft. Continue crossing the strings and adding lighters until fourteen are bound into a float; then

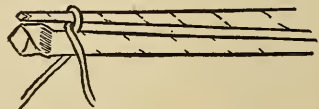

Fig. 471.—Second lighter is in place.



Fig. 472.—Lower string up and upper string down.



Fig. 473.—String crossed and carried over third lighter.

tie the ends of the strings on each line securely together (Fig. 475), and your work will be ready for the fitting of the little mast, which must stand erect at one end of the raft.

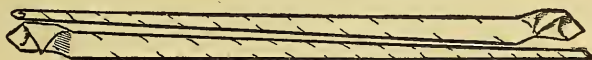

Fig. 474.—Alternate large and small ends of lighters.

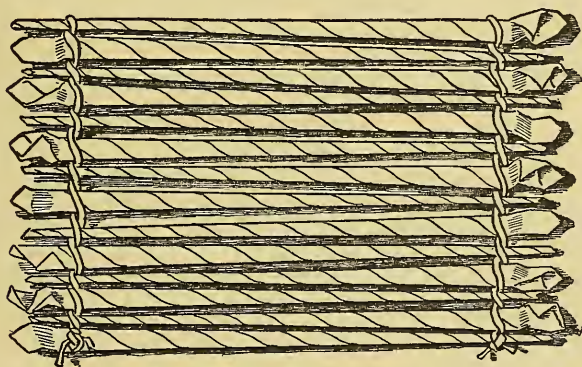

Fig. 475.—Bind the raft together.

Use the remaining lighter, which is the fifteenth, for the mast; flatten out the large end and slide it through the central opening or crack of the raft between the seven lighters on each side; then bend the flat end of the mast along the under side of the next

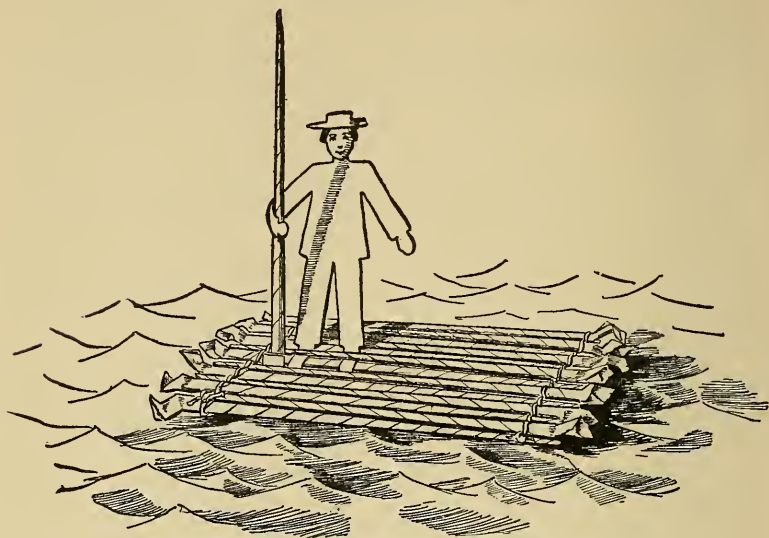

Fig. 476.—The raft is launched with lumberman on board.

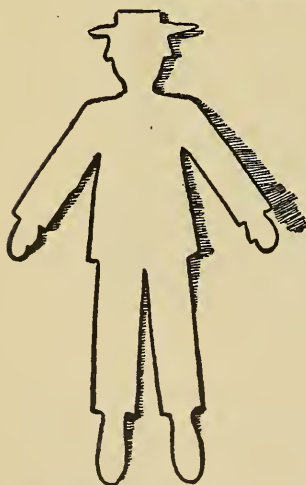

Fig. 477.—The little lumberman.

lighter, up through the next space, over the next lighter and down through the forward space. Weaving it over and under the lighters of the raft keeps the mast firm and steady (Fig. 476).

#### Make a Little Lumberman

like Fig. 477. Fold a piece of white writing paper; trace one-half of the lumberman on it (Fig. 478), and cut out the figure. When he has been painted and waxed, stand him by the mast with one arm around it. Weave his feet in the raft as you

wove the mast, and he will stand up as straight as a good soldier (Fig. 476).

**Launch the Raft**

on the water; it will dance merrily over the waves, and you can have some of the other wax children climb up and sit on the raft as it goes floating about. Should the children tumble off into the water, let them swim for a while, for that is what they want to do. Then you can help them on the raft again or bring them to land.

When the raft is riding the waves, the four bathers holding on the life-line and the other wax girls and boys playing in the sand, wading and diving in the water, let a mermaid come slowly swimming through the water toward them.



Fig. 478.—Half of the lumberman.

**Make the Mermaid**

of paper and her flowing tresses, also of paper. Mermaids are famous for their beautiful hair, which they seem to be always combing with a golden comb. Your mermaid, though, must be content to swim and enjoy herself without the golden comb.

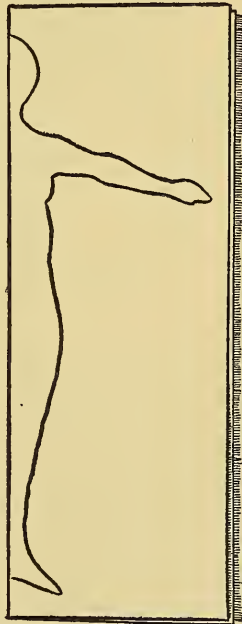

Fig. 479.—Fold the paper and cut like this.

Fold a piece of white writing paper; trace the lengthwise half of the figure on it (Fig. 479) and cut out the mermaid (Fig. 480); then cut two pieces of rather long, finely fringed paper (Fig. 481) for the hair, and paint them golden brown on both sides. Paint the back of the mermaid's head and the hair around

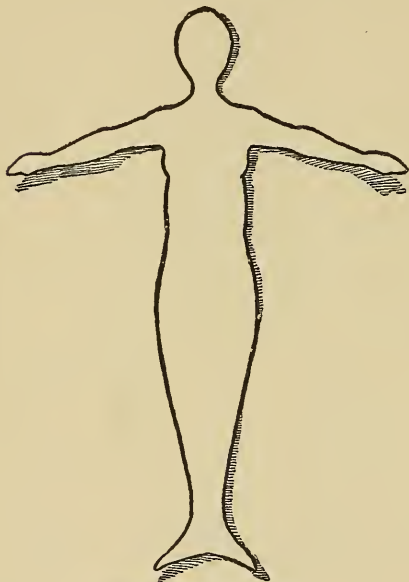

Fig. 480.—The mermaid.



Fig. 481.—The mermaid's hair in two parts.

her face the same color. Mark the features with ink; when dry, color the face, arms and body pink; paint the remaining part of the figure gray. After the paint has dried mark fish scales from the waist down; then glue the straight top fringe of hair across the centre of the back of the mermaid's head from side to side. Glue the other piece at the extreme

top of the back of the head. After the mermaid is thoroughly dry, bend all of the hair out from her head. Do not allow any of it to lie down flat. Bend the body a little backward in a curve from the waist-line, the arms forward; then wax the



Fig. 482.—The mermaid has flowing tresses.

mermaid, hair and all (Fig. 482). When the mermaid is in the water, the little wax children will make friends with her, and she will perhaps tell them fairy stories of the beautiful life under the waves.

These water toys will last a long time if well cared for and kept in a cool place where the wax will not melt.



The Process is Very Simple.



## CHAPTER XXIX

### HOW TO WEAVE WITHOUT A LOOM

#### Method Invented by the Author



UGS, portières, table covers, bedspreads, hammocks, in fact, almost anything that can be woven of rags, can be woven without a loom. Any one can do it, for the process is extremely simple and all that is required is a board, a paper of tacks and some rags cut in strips. These may be old rags or new, silk, cotton or wool, and the piece may be woven heavy or light, in a close weave or a loose one,

to suit its intended purpose. Many colors or few can be used, and the patterns can be as varied as the colors, for any design in straight lines can be followed in the weaving. A snip of the scissors will cut off one color, a stitch or two insert another, and so the pattern grows. It is quick work and you will find it very absorbing as you sit amid your vari-colored rags and see them grow beneath your fingers into harmoniously colored hangings or soft, warm rugs.

#### A Board

forty inches long will answer for weaving anything one yard or less in width and is of a convenient size to handle. The one-yard width is what an ordinary loom produces, but if you would

have your rug or portière wider there is no reason why the board should not be longer. To prevent the material from catching, your board must be smooth on both sides and on the edge and it should be as wide as possible. A good-sized pastry board is excellent for weaving a piece less than twenty-two inches in width.

#### **Rags are Used**

for both warp and woof; if old and soft they should be more tightly packed than when new and firm. The warp is composed of the strips which run up and down in the work, the woof of those that are woven in and out across the warp, and the process is like that of weaving a splint basket. The following directions are for making

#### **A Blue and White Cotton Rug**

for bedroom or bathroom. Heavy, new canton flannel is a good material for the rug and it is better to have new goods where the weave, as in this case, is to be smooth and flat.

Cut the canton flannel, do not tear it, into strips half an inch wide, but do not sew the strips together, and make into balls as for loom weaving; piece them as needed while the work progresses. Draw a straight line the whole length of the board one inch below the top edge, then along this line

#### **Tack the Warp**

As there is to be a blue border four inches wide, entirely around the rug, the warp at first must be all blue.

Take one strip of the blue and tack it on the line at the upper left-hand corner of the board about two inches from the side edge. Leave one end of the warp longer than the other and drive the tack only part of the way in (Fig. 483). Give the strip

two twists toward you, close to the tack, and fasten it down with another tack on the line just half an inch from the first tack. See Fig. 484.

Fasten your strips on in this way with the tacks half an inch

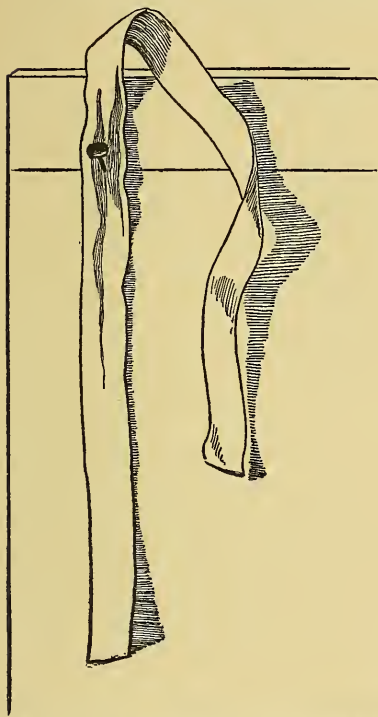

Fig. 483.—Tack one strip of blue on the line.

apart and you will have eight ends or eight strips of warp which will form the side border. For the top border cut the blue strips into ten-inch

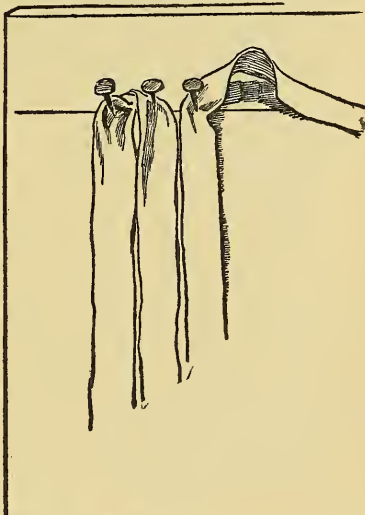

Fig. 484.—Fasten it down with another tack.

pieces, twist them at the middle so that the ends will be of an even length, and tack them along the line as far as you wish the centre to extend; then add the longer strips of warp for the other side border, as in Fig. 485. To the ends of the short blue warp sew strips of white, lapping the ends with the blue on top.

Sew them securely like Fig. 486 and whip the end edges to make them lie perfectly flat.

This will give a white centre of warp with a blue border at the top and sides. Draw each strip of warp down until it is smooth and taut and tack it near the bottom edge of the board. Be very careful to have the warp of the border

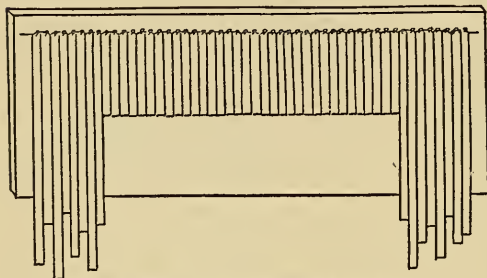

Fig. 485.—This will make a border.

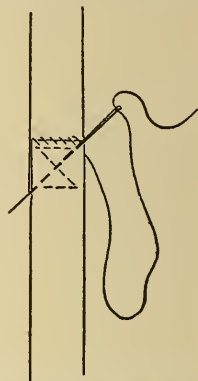

Fig. 486.—Sew the pieces securely.

and the centre measure the same distance across the bottom as across the top and keep each strip in a straight line from the top (Fig. 487). Frequent measurements while weaving will keep your rug true and prevent narrowing between the two rows of tacks.

When the warp is ready take a strip of blue and begin

### To Weave

Tack the end of the strip, which is now the warp, a little to the left and a trifle below the upper left-hand tack (Fig. 487) and, starting under the first strip of warp, weave it in and out several times; then draw the warp out its full length as you do a needle and thread after taking several stitches. Keep the warp flat and even when it is woven and push it up close to the

tacks. Weave across in this way, always under one and over the next, and drawing out the end of the woof every little while. When you have reached the last strip of warp on the right, turn the woof over it and weave back again in the same manner (Fig. 487).

The woof for this rug is entirely of blue, and as you weave across the white warp you will find that it makes a blue and white checker-board centre.

When you have woven as much as you can between the two rows of tacks, take the tacks out,

#### Move the Woven Part Up

and tack across again along the second or third row of woof from the bottom, putting a tack through the woof into each strip of warp; then draw the warp down as at first and tack in place. Fig. 488 shows the two rows of tacks after the rug has been moved up and also the effect of the checker-board weaving and blue border. This manner of moving up the woven part makes it possible to weave any length you may desire.

#### Lengthen the Warp

as you weave by sewing on new pieces, and when the centre is almost as long as you want it, cut off the white warp evenly and

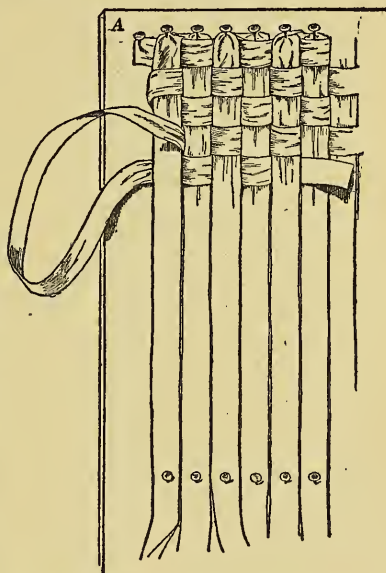

Fig. 487.—Keep the warp perfectly straight.

sew on blue, then weave until the border at the bottom is the width of that at the top and sides. Cut off the woof that is left after

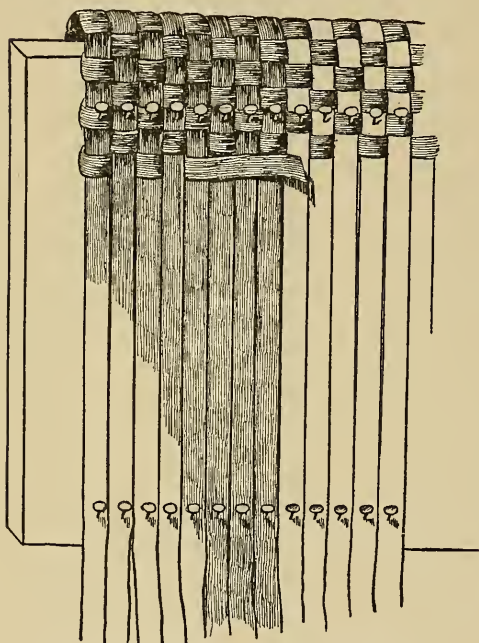

Fig. 488.—After the rug has been moved up.

weaving the last row, and, turning in the end, sew it securely to the last row of warp.

Cut Off the Warp, leaving ends about one and one-half inches long; turn each end of the warp over the last row of woof and sew it down. One end will turn on one side of the rug, the next on the other side, as splints turn over the edge in binding off a splint basket.

It is best to cut off one end of the warp and sew it down before cutting the next, as this will prevent the woof from slipping out of place during the binding off. Tuck each end of the warp under the row of woof just above it and sew again. Fig. 489 shows how this is done. G, H and I are the ends of the warp cut off evenly, F is an end turned up and sewed to the bottom row of woof. E is an end which is to turn under and be brought up on the other side of the rug. D has been turned up, sewed to the last row of woof and is just being slipped under the third

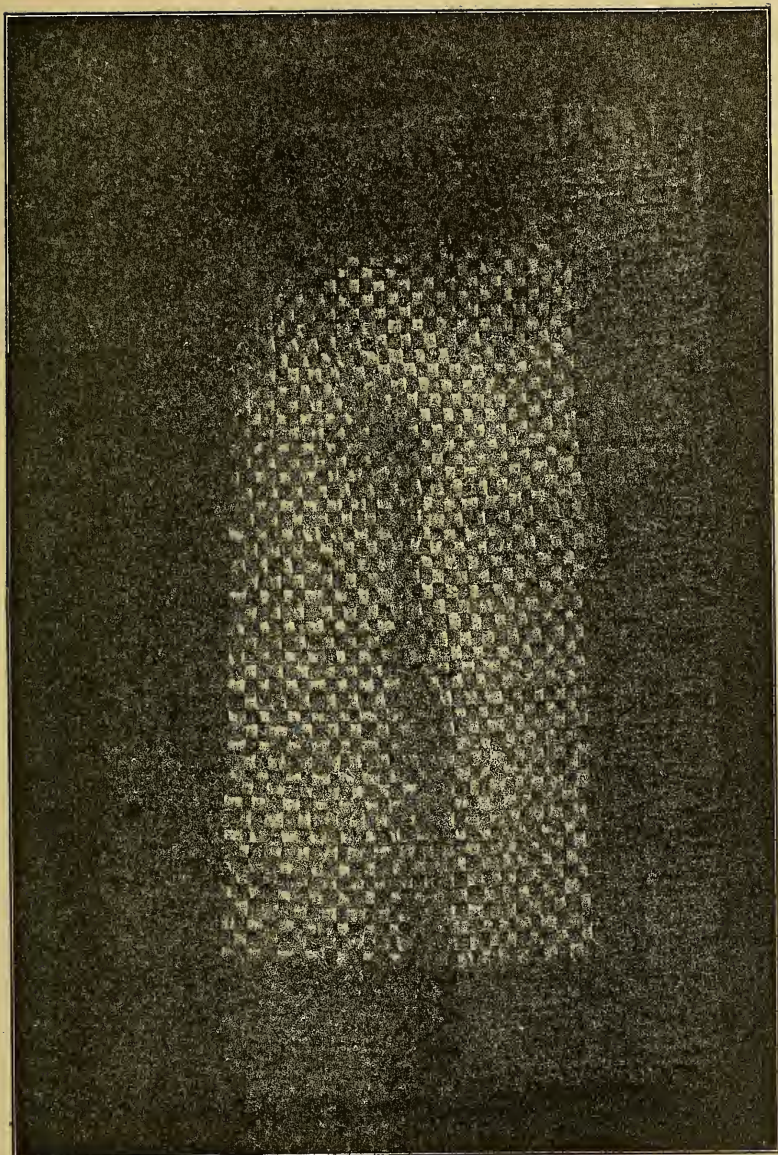

Fig. 490.—Rug Woven by the Author.





row of woof, J. C is turned under and fastened in place on the other side of the rug, and B has been turned up, sewed, tucked under the third row of woof and sewed again. The end is shown above the woof to make the idea plainer, but in reality it should be hidden under the woof.

When the last end of the warp has been secured and the first end of the woof (Letter A, Fig. 487) has been turned over and sewed to the warp, your rug is finished and will look like Fig. 490. This rug is photographed from one made by the writer on a pastry board. Its size is twenty-two by thirty-four inches. Three-quarters of a yard of white canton flannel and one yard and a half of blue were used for weaving.

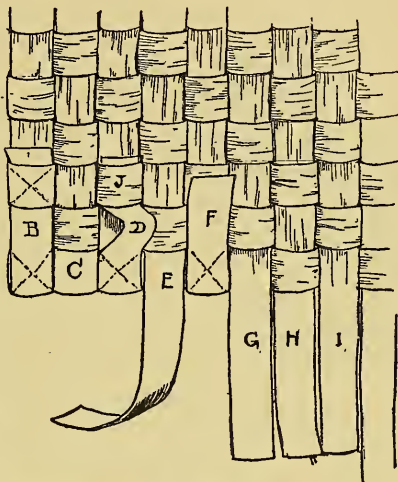

Fig. 489.—Finish off the end of the rug in this way.

### To Make a Heavier Rug

with the flat weave, double the warp. That is, lay one piece of warp directly on top of another, giving two thicknesses to each strip. A close weave is made by using soft material, tacking the strips close together for the warp and pushing the woof up tightly, crushing it together as in loom weaving.

Diamonds, squares and Indian zigzag patterns are easy and you can work out others quite original with yourself.

## CHAPTER XXX

### HOW TO MAKE YOUR OWN EASTER CARDS AND GIFTS



EVERYTHING awakens with new life and rejoices on Easter; and the dear old Earth smiles with sympathy and brings her offering of sweet flowers. It is the day when all people, little and big, young and old, should be filled with joy, because Easter means the Resurrection. It means life, light and immortality. It is the blest assurance and certainty that love and goodness are the realities of life; far more precious are they than the inanimate material things you can see and touch. But we can use material things to convey to our friends the invisible, wonderful good of love, joy, kindness, sympathy, tenderness, and friendship.

A simple, inexpensive Easter card may carry with it happiness, for "it is sweet to be remembered," and you can think of many designs from which to choose a cheery greeting to send to every one.

#### Cards Made to Represent Easter Flowers

are always welcome. Trace Fig. 491 on heavy paper; paint the flowers to resemble as nearly as possible the natural blossoms, shading the lily lightly and coloring the passion flower in natural hues. Paint the violet a light blue purple and its foliage green. When dry cut out the design; then bend the card at the dotted

lines that each flower may stand erect, supported by the blank back piece in tent-like fashion. When bent the card will form three tents in a row, with the smallest in front, as in Fig. 492.

If you are not able to paint the flowers satisfactorily, use any colored, printed flowers you happen to have, either the embossed ones that come for scrap books, or those cut from colored advertisements or newspapers. Select three different blossoms or groups of flowers and, taking the largest first, lay it down flat on a strip of stiff paper with the stems or lower part toward the edge of the paper; then run a pencil line entirely around the edge of the flower; this will give a blank enclosed by the outline of the flower. Place the same blossom on the paper again, being sure to bring the top of the flower to meet the top of the out-



Fig. 492.—The Easter flower card.



Fig. 491.—Pattern of standing flower card.

line flower, in order that the two parts may fit; then make a second tracing. Examine the lily in Fig. 491 and you will understand more clearly. Unless the two flower tops meet, one side of the flower tent will be upside down.

Place the middle-sized blossom on the paper with the lower part next to the lower portion of the first and largest flower, in the same way that the back support of the passion flower meets the lily stems in Fig. 491. Trace this twice as you did the first design. The last and smallest flower must be traced in like manner. Notice in Fig. 491 that the leaves of the violet meet the lower part of the passion flower, while the blossom of the violet meets the outline of the blossom.

When you comprehend the principle the work will be very easy. Paste each bright blossom immediately in front of its back support; then cut out the entire long card and bend it into three tents which will enable the flowers to stand up and look very attractive. These floral cards may be folded and brought together in flat layers, to be sent by mail without danger of injury.

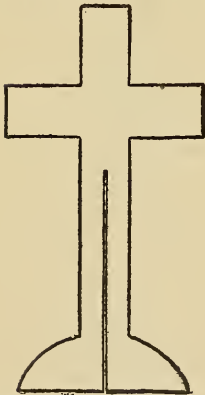

Fig. 493.—One half of the cross.

### The Cross

is a most appropriate design for Easter. You can make one of cardboard which will stand alone. Cut Figs. 493 and 494 from stiff paper, and make the slit down through the top of one and up through the bottom of the other; then slide the two crosses

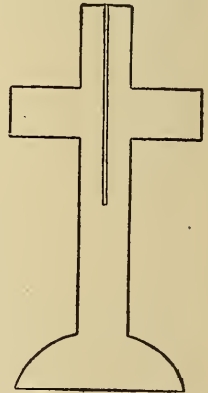

Fig. 494.—The other half of the cross.

together by placing Fig. 493 at right angles down through the top of Fig. 494, adjust the two pieces and your cross will resemble Fig. 495. The card may be closed flat by turning the two crosses until they lie closely against each other. You can decorate this double cross by painting or pasting flowers on it, or lettering it with the words, "Easter Greeting."

Another new design is

### The Tulip Bud

(Fig. 496). This you can open at will and make it blossom.



Fig. 496.—The tulip bud.

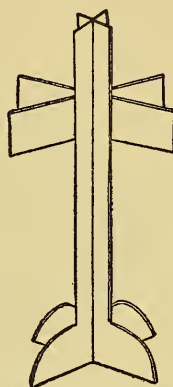

Fig. 495.—Put the two halves together in this way.

Open it still further and the petals appear as if ready to fall, as in Fig. 497. Cut Fig. 498 of white paper and paint it to resemble a tulip petal; make five more petals, then trace Fig. 499 on a piece of cardboard, fit the six petals together and place them on top of the tulip stem (Fig. 499). Hold the petals firmly in position while you run a coarse needle and thread through the petals and cardboard back in order to fasten the flowers on the stem. Knot the thread on the outside of



Fig. 497.—The open flower.

the petals and also on the wrong side of the pasteboard card. Fig. 500 shows the knot on the lower portion of the petals. Draw the thread tight to keep the petals firmly in place. Paint the stem and leaves green and paste a small round piece of paper over each of the knots which fasten the flower on its stem as shown in Fig. 501. When the bit of paper is painted it will never be noticed.

You can use this idea with another flower if you do not understand painting in water colors.



Fig. 498.—The tulip petal.



Fig. 499.—Tulip stem and leaves.



Fig. 500.—The knot in the petal.



Fig. 501.—Paste paper over the knots.

### The Dainty Bloodroot

wildflower blossom is pure white and you can cut the petals of white paper, and fasten the flowers on gray-green cardboard. Paste the stem securely down and sew the petals in place in the same manner as those of the tulip. The bloodroot will look especially pretty when you move the petals and cause the snowy flowers to open.

One of the most beautiful of manufactured Easter eggs was the one presented to an Infanta of Spain some years ago. The Gospel of Easter day was inscribed on the inside of the white enamelled shell, and when a secret spring was touched a little bird would fly out and sing. It was said to have cost four thousand dollars. We can make an

### Easter Egg Card

that will give almost, if not quite as much pleasure, for not more than four cents. This will be of pasteboard and will fold flat like the cross, but when opened a little chicken will sit up on

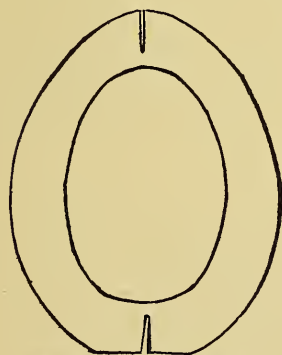

Fig. 502.—Half of the egg.

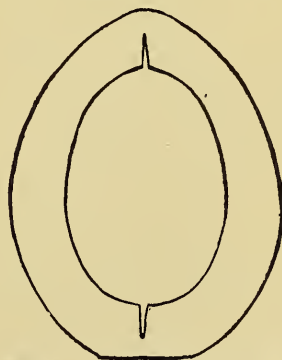

Fig. 503.—The other half of the egg.

the inside with its beak wide open and its wings lifted as if ready to sing its little chickie song. More than that, our egg will stand firmly on one end as Christopher Columbus made his famous egg stand.

Trace Figs. 502, 503 and 504. Slide the first egg (Fig. 502) in at right angles through the second (Fig. 503); fit the slits into each other. Paint the chicken (Fig. 504) a soft light yellow, and when dry make the markings with ink; then



Fig. 504.—The outline of the chicken.

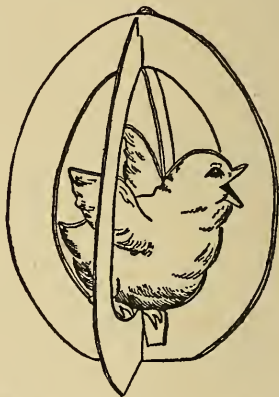

Fig. 505.—The little chicken will sit up on the inside.

slide the slit at the feet of the chicken diagonally over the lower cross portion of the two eggs and you will have Fig. 505.

In Jerusalem the

### Easter Bells

ring out at precisely nine o'clock in the morning, telling the people that the religious ceremony of the washing of the feet is about to take place in the large court just outside the Church of the Holy Sepulchre. On Easter morning in our own land the church bells ring out joyously; and the gladdened note seems to



be given unconsciously by the bell ringer, some of his Easter joy having entered into his work.

Our Easter card of bells is fashioned after the old Spanish style of architecture, in which the church bells are often seen suspended in open alcoves which are built up flat above the body of the church. Copy Fig. 506 on cardboard and cut it out. Make three bells like Fig. 507 and fasten one on each of the three round dots on the church belfry (Fig. 506). Sew the bells in place as you did the tulip petals, but in this case allow the thread to be a trifle looser

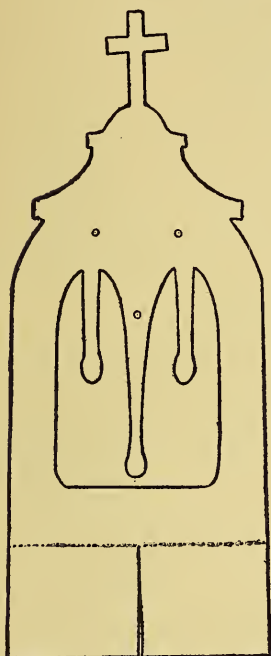

Fig. 506.—Cut this out of cardboard.



Fig. 507.—Make three of these bells.

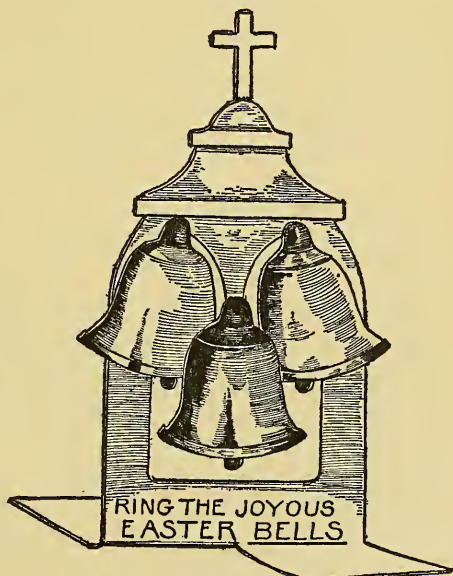

Fig. 508.—The Easter bell card.

that the bells may sway back and forth, as if ringing, when you move the card. Cut up the slit through the centre of the stand of the card and crease along the dotted line, bending half of the stand forward and the other half backward. This will give a

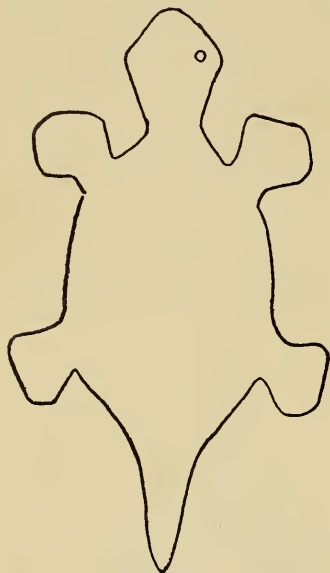

Fig. 509.—The turtle without his shell.

good platform and the card will stand alone (Fig. 508). Make the belfry (Fig. 506) of a warm gray-colored cardboard and gild the cross and bells. When dry indicate a slight shading with pen and ink. Here are some original Easter toys to be used as small gifts or novel dinner cards.

**Let the Comical Little Turtle**

be the first you make.

Draw on heavy writing paper Fig. 509. Cut it out, and from white tissue paper make two strips like Fig. 510. Paint eyes and mouth on the head and mark the feet; then with strong glue or sealing wax cover the edges of an egg-shell cut lengthwise and place it on Fig. 509; next fasten a strip of tissue paper (Fig. 510) along the side of the turtle between the fore and hind foot, making the strip reach partly on the egg-shell and partly underneath on the writing paper; this is to make the egg-shell and the heavy writing-paper adhere more firmly together. Fasten the remaining strip on the other side of the turtle in the same way, bend the head up

#### Let the Comical Little Turtle

be the first you make.

Draw on heavy writing paper Fig. 509. Cut it out, and from white tissue paper make two strips like Fig. 510. Paint eyes and mouth on the head and mark the feet; then with strong glue or seal-



Fig. 510.—Two tissue paper strips.

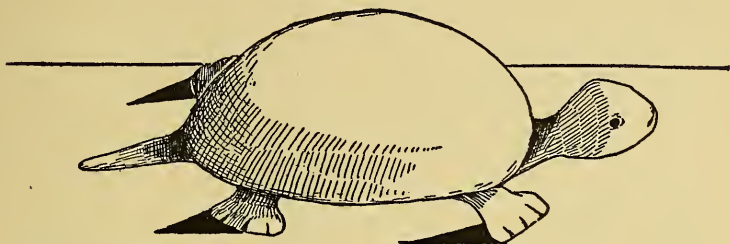

Fig. 511.—Just like a real turtle.

a little and the tail down, also bend all the feet down and the result will be a queer little Easter turtle able to stand alone (Fig. 511).

**Now for the Funny Little Pig**

(Fig. 512). Select a good-sized white egg and blow out its contents in this way: carefully bore a hole at each end of the egg, enlarging them only sufficiently to enable you to send its contents out of one end by blowing in the hole at the other end of the egg; this done, cut from strong, stiff paper or cardboard dia-

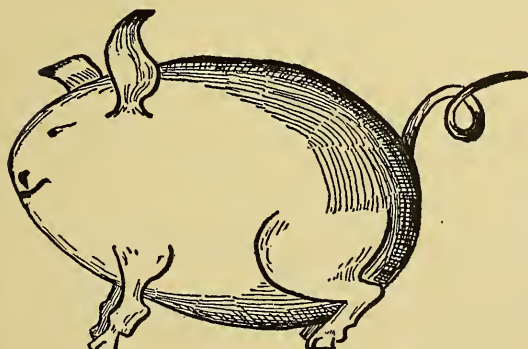

Fig. 512.—Such a ridiculous little pig.



Fig. 513.—Pig-  
gie's tail.

gram, Fig. 513, the tail; Fig. 514, the fore leg; Fig. 515, the hind leg; Fig. 516, the ear. Make two ears, two fore and two hind legs. Mark eyes, nose, and mouth on the small end of the



Fig. 514.—Piggie's fore leg.



Fig. 515.—Piggie's hind leg.



Fig. 516.—Piggie's ear.

shell; curl the tail with a penknife or scissors and glue it on the pig by spreading out the slits and fastening them on the back of the pig; then in turn glue in place the legs and ears and behold! the pig (Fig. 512).

### The Spoon

(Fig. 517) requires a lengthwise half of an egg-shell, a piece of stiff cardboard and a bit of plain white tissue paper for its manu-

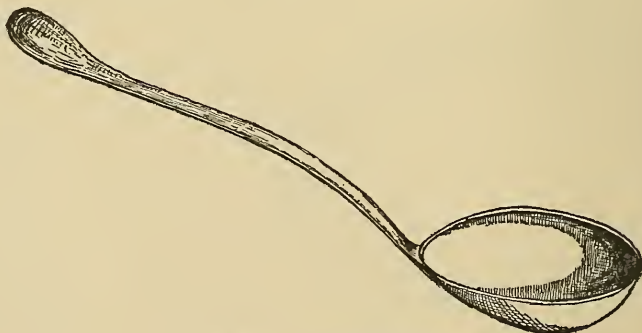

Fig. 517.—An egg-shell spoon.

facture. Cut the edges of half a shell evenly all around with a pair of sharp scissors, being careful not to crack the shell during the operation; then cut the handle from cardboard (Fig. 518). Glue and attach the handle with sealing wax on the outside of the small end of the shell, bending the

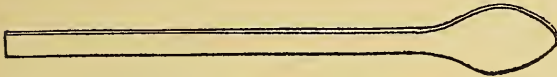

Fig. 518.—Cut the handle from cardboard.



Fig. 519.—The tissue paper fastening.

handle down a little where it joins the shell, secure the handle still more tightly in place by fastening a piece of tissue paper (Fig. 519) over that portion of the handle which is glued to the egg-shell, allowing the tissue paper to extend out a little beyond either side of the handle and fasten the extensions tight down on the shell. When finished the spoon can be gilded along its edges or otherwise ornamented (Fig. 517).

### An Umbrella

made of half an egg-shell would protect us from the rain if only it were large enough, but such an umbrella is a good size for your purpose, because you desire an odd little toy and here it is (Fig. 520). To make the umbrella, cut from paper (Fig. 521), fold it together as in Fig. 522, turn down and outward the upper flaps; then glue the two

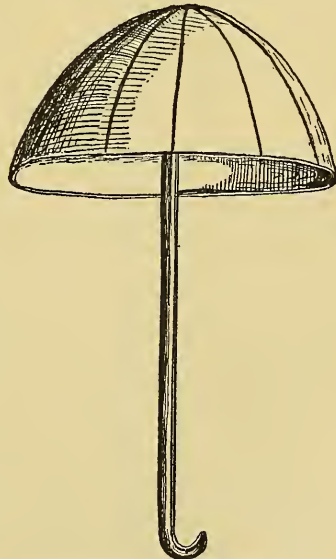

Fig. 520.—A little umbrella.

sides of the folded handle tightly together; next fasten the spread-out flaps down on the inside centre of half an egg-shell with sealing wax; be sure to make the handle come in the middle of

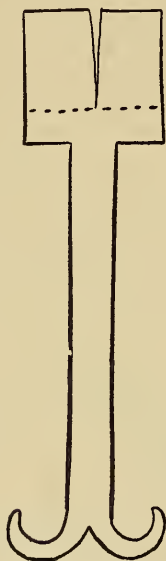

Fig. 521.—Cut the umbrella handle like this.



Fig. 522.—Fold the handle in this way.

the shell, otherwise the umbrella will lop over a little to one side. The rim and handle may be painted brown or black, and lines to represent the seams of a real umbrella can be made on the outer surface of the shell.

### The Doll's Chair

is not difficult to make. Cut Fig. 523 from medium-weight paper, not too heavy, ornament it as in Fig. 524 or in any other way you may fancy, then take half an egg-shell and glue the

chair seat over the open end with melted sealing wax, bend the back in an upright position and allow the slit edges of the seat to be bent down on the egg-shell and fasten in place. The bottom of the shell must be levelled off a little and the hole cov-

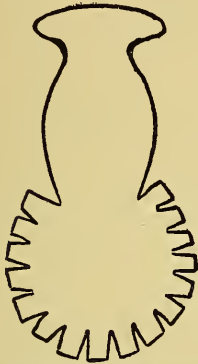

Fig. 523.—The back and seat of Dolly's chair.



Fig. 524.—Dolly's chair.

ered with a piece of paper, in order to make the chair stand up as it should. If tinted paper be used in making this toy it enhances the appearance, though the colored paper is not necessary, as white ornamented makes a very pretty little chair.

### Strawberry

The strawberry is in reality a candy box. Take a fine-looking egg and blow out its contents, then dye or paint it red and with black ink mark the dots as in Fig. 525. Next fill the egg-shell with small candies and cover the opening at the top with a piece of green tissue paper cut like Fig. 526. Fasten the paper on the shell with paste used sparingly and only where it is necessary. On the top of the strawberry glue a bow of narrow green ribbon



Fig. 525.—The egg-shell strawberry.

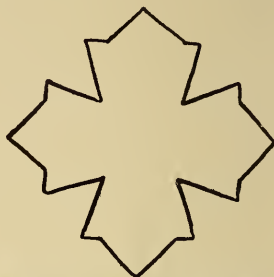

Fig. 526.—Paste this on top of the strawberries.

and the candy box will be finished and ready for a unique Easter gift.

### A Little Hanging Basket

can be fashioned from half an egg-shell with narrow ribbon pasted over its edge, a bow of the ribbon on the bottom and two more at the sides covering the ends of a loop of the same narrow ribbon securely glued on the shell (Fig. 527).



Fig. 527.—A little hanging basket.

### The Doll's Cradle

(Fig. 528) is made by breaking the egg in the desired shape, first drawing a line with pencil, so that it may be

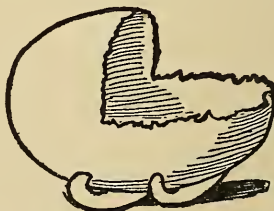

Fig. 528.—Dolly's cradle.



correct, then piercing the pencil line with a fine needle. The wee cradle thus formed is pasted on rockers made of stiff paper and bent down at each end (Fig. 529).

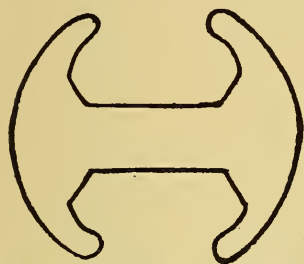

Fig. 529.—Cut the rockers by this pattern.

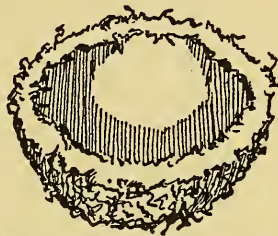

Fig. 530.—An egg-shell bird's nest.

### Bird's Nest

The bird's nest is simply half of an egg-shell, the outside covered first with a thin coat of glue and then with moss. This is to be filled with candy eggs (Fig. 530).



Fig. 531.—The little sail boat.

### Sail Boat

The egg-shell boat will sail very prettily in a basin of water. It is half of a shell, with a tissue-paper sail (Fig. 531), the mast cut of stiff paper (Fig. 532), folded at the dotted line. Fig. 533 is the sail cut from colored or white tissue paper. The straight edge of the sail is placed in the fold of the mast and the two halves of the mast pasted

together down to the cross line at the bottom. This lower part is slit up, as in diagram 532, and the flaps bent in opposite direc-



Fig. 532.—Make the mast of stiff paper.



Fig. 533.—A tissue paper sail.



Fig. 534.—The pennant.

tion. These are used for braces in holding the mast upright and are glued to the bottom of the boat. The pennant (Fig. 534) is cut of bright-colored tissue paper, and fastened on the top of the sail (Fig. 531).

Fig. 535 represents the head of

### The Mikado



Fig. 535.—The head of the Mikado.

fashioned from an egg. The egg must first be pierced at both ends, and the contents blown out, leaving the hollow shell; then a face, as nearly as possible resembling the Mikado, painted on the egg. A narrow strip of black paper (that encasing needles will answer the purpose) must be pasted on the back of the head, and made to stand erect with the

top end curled forward as in Fig. 535; the egg should then be painted black, except the face, as seen in the picture. The head must be made to stand in the same manner that Columbus made his egg stand, by levelling off a portion of the end.

**To Make the Pin-Cushion**

(Fig. 536), cut two pieces of satin or silk of any desired color by pattern (Fig. 537); sew the two pieces together, leaving a small opening; fill the bag with bran, sew up the opening, and tie around the egg cushion a narrow ribbon matching the color of the cushion, making a fancy bow at one end, and a bow and loops at the other. Place in pins to form the word "Easter" (Fig. 536).



Fig. 536.—The Easter egg pin-cushion.

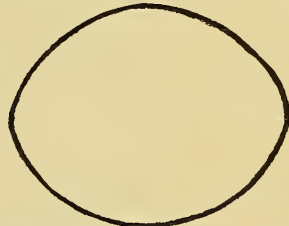

Fig. 537.—Cut the pin-cushion by this pattern.

Fig. 538 shows the head of

**Napoleon,**

and that you may not be behind the times in your hero worship, I am going to tell how you may make a little Napoleon for yourself. At least you may make a Napoleon head, and Napoleon's head was really the greatest part of him; his heart, I fear, was not so great, and his body, we know, was insignificant.

Use a goose egg for the head; the dimensions given for the hat are intended for a large egg. Blow the egg from the shell in the manner described. Make the largest hole in the small end of the shell and enlarge this hole to the size of a silver dime.

Now, Napoleon had what is called a well-balanced head. That was one cause of his greatness; it could not be upset by

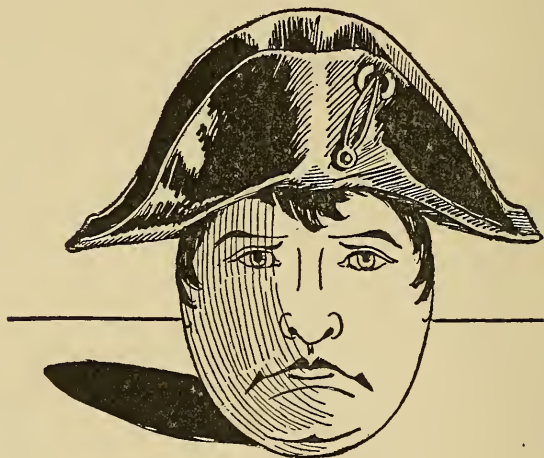

Fig. 538.—Napoleon.

anything that went on around him. So, to make a head that will bear the stamp of Napoleon's character, we must contrive to have it keep its position, or balance; to stand erect, unaided and alone, and it can be done in this way:

When the egg has been blown from the shell place the shell in a perfectly upright position, large end down, in an egg-cup, or anything that will hold it steady. Into the large hole pour a little melted sealing wax, and on top of that pour a little melted

lead, or some pieces of shot, taking care to have the weight fall directly in the centre to make a perfect balance.

Fig. 539 is Napoleon's face, which you must draw on one side of the egg with black ink. Ink the hair black. Blacken the shell on the other side, too, for the hair on the back of the head. In drawing the face on the shell remember that the

largest end of the shell is the chin, the smallest end the top of the head. To be sure, the real Napoleon never had a hole in the top of his head that we ever heard of, but the hole in the top of our Napoleon's head will not show when his hat is on, and as the hat is to be glued in place no one will ever be any the wiser.



Fig. 539.—Napoleon's face.

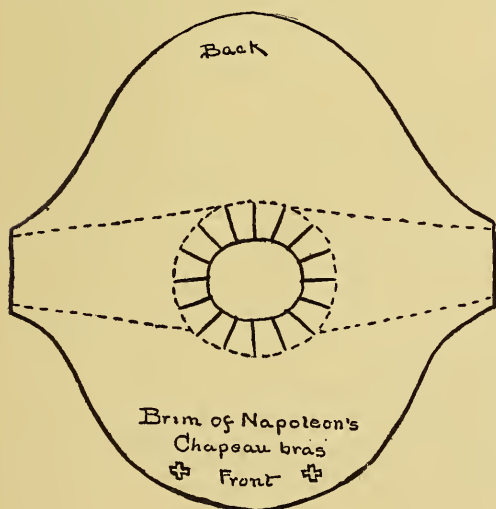

Fig. 540.

To make the hat, or

"Chapeau Bras,"

as Napoleon would have called it, and which means a military cocked hat, you must have some black paper. For the brim a

piece five inches square will be needed, as it measures just that many inches from front to back and from side to side. Cut out the brim from pattern (Fig. 540). Cut the hole near the centre and cut the slits around it as shown by the heavy lines. Bend up the little strips or laps, as denoted by the dotted line around the hole. The other dotted lines show where the brim is to be turned up front and back, but the crown must be glued on first.

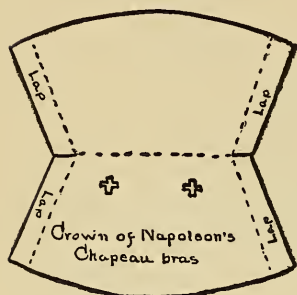

Fig. 541.

Fig. 541 is the pattern of the crown. From front to back it measures three inches; from side to side, at its widest part, three and a quarter inches; at the narrowest part the measure is two inches. The heavy line shows where it is to be cut, the dotted line where it is to be folded. Turn in the laps at the sides, bring them together and paste neatly. Fit the crown on the brim, over the laps

of the brim, and paste the laps of the brim to the inside of the crown. Turn up the brim according to the dotted lines on Fig. 540. At the points shown by the crosses on the front of the brim put a drop of paste and bring them up to meet the crosses on the crown of the chapeau. Place Napoleon's chapeau on Napoleon's head as in Fig. 538, and glue it to the shell. Now set the little hero before you on the table, touch him with your finger, and, if the weight has been well placed, he will nod and bow, but his head will always regain its level position.

Hero though he is, Napoleon is the better for a companion, and we will give him his first wife, Josephine, whom he crowned Empress of France on December 2, 1805, the day of his own coronation.

To express in a measure the regal dignity of

### Josephine

on that occasion, her head must also be held erect; prepare the shell, therefore, as you did the one for Napoleon's head, with this



Fig. 542.—Josephine's face.

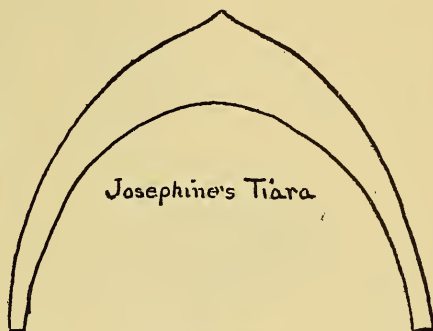

Fig. 543.

difference—place the weight in the small end of the egg-shell, instead of the large end.

Draw Josephine's queenly countenance (Fig. 542) on the egg-shell, placing her chin at the small end. Make her tiara of gold paper, which you can spangle, if you like, to represent the diamonds of which it was composed. Fig. 543 shows how to cut it. Fig. 544 is the pattern for her crown and should also

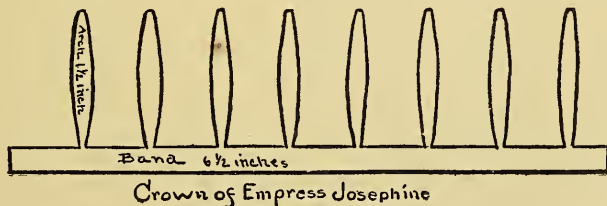

Fig. 544.

be made of gold paper. Paste the two ends of the band of the crown together to form a circle, then draw the ends of the arches



Fig. 545.—The Empress Josephine.

together to meet in the middle, over the top. Fasten these together with needle and thread on which a small glass bead has been strung. The bead will hide the stitches and also take the

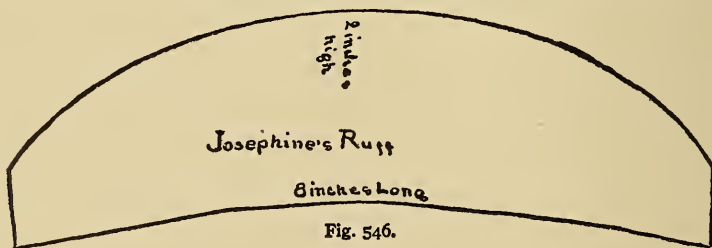

Fig. 546.

place of the small cross which occupies that position on the crown of the real Empress. With your finger curve the arches out as shown in the sketch of the finished head (Fig. 545).



The crown and tiara are not fastened together, but are placed on separately, for Josephine wore the diamond tiara when she was crowned. Glue the tiara to the head first, bringing the ends around to meet rather low down at the back; then set the crown back of the tiara and glue in place.

From a piece of white tissue paper cut a ruff, after pattern (Fig. 546); crimp the ruff with the blade of a knife or scissors and glue to the back and sides of Josephine's head.

These little heads will be very amusing if you place them opposite each other and set them nodding and bowing, Josephine to Napoleon and Napoleon to Josephine.

The materials used for the

#### Good-morning Chick

are simply an egg-shell, a piece of wire, some light-yellow worsted, two black beads and a small piece of writing paper.

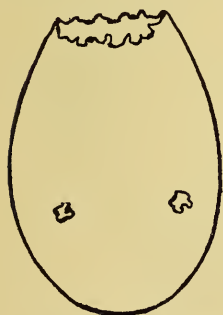

Fig. 547.—Cut off the small end.

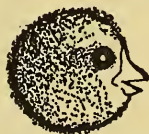

Fig. 548.—The chicken's head.

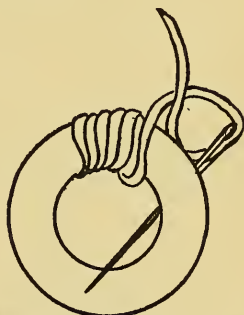

Fig. 549.—Wrap the rings with worsted.

Select a nice large egg, and with a sharp knife cut off the small end, as evenly as possible, Fig. 547. After emptying the shell rinse it carefully, and while it is drying make the chicken's head (Fig. 548); cut from a light quality of cardboard

two rings like Fig. 549, place them together, and with the worsted wrap the rings over and over, as shown in Fig. 549, until the hole in the centre is nearly filled up; then, holding it firmly between the forefinger and thumb, insert the point of a pair of sharp scissors in the outer edge, slipping it between the two rings; cut



Fig. 550.—The upper part of the beak.



Fig. 551.—The lower part of the beak.



[Fig. 552.—The beak.

the worsted all the way around, and, still holding it firmly, slide a piece of strong thread between the rings, and, drawing it around once, tie tightly. Take the rings from the ball thus made, and clip and trim it perfectly round. Sew the two round black beads



Fig. 553.—Use hat-wire for the legs.



Fig. 554.—The foot.

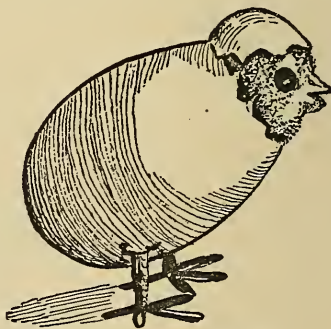

Fig. 555.—Good-morning.

on the head for eyes; make the beak of writing paper after Figs. 550 and 551. Fig. 550 is the upper, Fig. 551 the lower part of beak. Pinch into shape as shown by dotted lines; and with a little mucilage stick the upper end of Fig. 551 to the underside

of Fig. 550, as in Fig. 552. Paint the beak a light yellow, and gum to the head. Fig. 548 shows the head complete.

Holes must now be made in the shell for the legs to come through, as shown in Fig. 547. This is done by boring carefully with a large, sharp-pointed needle (being cautious not to crack the shell in the process), until the holes are large enough to admit the wire. Use a piece of ordinary black hat-wire, four

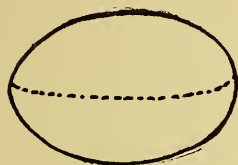

Fig. 556.—Run a line of perforations around the shell.



Fig. 557.—Fasten the shells together.

inches long, for the legs, bend in the shape of Fig. 553 and slip through the holes in the shell. Cut a piece of wire two inches long, and another one inch in length, for the foot; bend in the shape of Fig. 554 and fasten to the leg by wrapping tightly with black linen thread.

Fit the head in the hole left in the small end of the shell, and if the work has been well done the chicken will look very natural indeed. The small piece of shell taken from the end will give it a still more cunning appearance if fastened on the chicken's head (Fig. 555). This little trifle makes a very pretty *bon-bonnière*, as the shell is quite strong enough to hold candy, and the head may be removed to allow of its being filled or emptied.

To make the

## Good-night Chick

first blow the egg, then, boring with a needle in the manner previously described, run a line of perforations lengthwise around the shell, as seen in Fig. 556. This will allow of the shells being

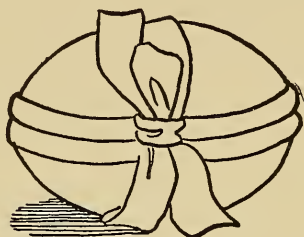

Fig. 558.—Nestle the chicken coseyly in the shell.

opened quite evenly. Cover the edges neatly with lutestring ribbon pasted down on both sides like a binding. Paste a piece of the same ribbon, twelve inches long, across the two halves of the shell, to connect them, as in Fig. 557. Make the little chicken, which should nestle coseyly within the shell, of two worsted balls, using rings two inches in diameter for the body. Trim the body into a slightly oval shape. The chicken's head is made in the same way as described for "Good Morning." Glue it to the body. In the illustration (Fig. 558) the egg is shown both closed and open, which will give some idea of what a pretty little gift it really makes. The entire chicken must be glued in the shell as it is not intended to come out.

opened quite evenly. Cover the edges neatly with lutestring ribbon pasted down on both sides like a binding. Paste a piece of the same ribbon, twelve inches long, across the two halves of the shell, to connect them, as in Fig. 557. Make the little chicken, which should nestle coseyly within the shell, of two worsted balls, using rings two inches in diameter for the body. Trim the body into a slightly oval shape. The chicken's head is made in the same way as described for "Good Morning." Glue it to

## CHAPTER XXXI

### HOMEMADE CANDLESTICKS



If you are working in clay try making a few candlesticks. If you haven't the clay, why not get some at once and begin this most fascinating work?

Candlesticks are always decorative; even the old tin candlestick with its half burnt tallow candle has a certain picturesqueness that the artist recognizes when he chooses that as an accessory to his picture instead of the

prosaic oil lamp. Then again, candlesticks give a wide scope to individuality in design, and that it gives expression to one's originality is one of the greatest charms of pottery making.

A potter's wheel is not at all necessary. The primitive method of coiling the clay and gradually, without hurry, building it up into the form desired is far the better way for home workers.

#### Get Your Clay

at the nearest pottery where anything finer than flower pots is made, and if it is a place where they turn out only earthenware ask for their finest clay. Very frequently they make a quantity

of extra pieces for holiday trade and for these prepare a finer clay than they ordinarily use. Fifty pounds of clay will keep you busy a long while and twenty-five pounds will be sufficient for a number of small pieces. It sells at about one and a half cents per pound at most of the potteries.

Break your dry clay into small pieces with a hammer and then pound to a powder. Put it into an earthen crock that has a cover of its own, and mix with water until it is of the consistency of dough. If you are not to use it immediately, and it is rather stiff, make several holes in the clay with your finger, fill each hole with water, cover the crock closely with its lid and set away until wanted.

When you are

#### Ready for Work

take out a good sized lump of clay, put it on a pastry board and knead it like bread. This is to work out all the air and make



Fig. 559.—Cut the clay in two with a knife.

the grain close and fine. If the clay seems too stiff spread it out in a flat cake, pour a little water in the middle, bring the edges together and knead again until the whole piece is softened. When the clay is too soft spread it out and

put it in the air where it will soon stiffen. If it is freezing out of doors do not expose the clay but let it dry off in the house. From time to time, while you are working the clay, cut the lump in two with a palette knife or ordinary knife (A, B, Fig. 559).



This Pottery was Made by the Author.





Put the outside edges together (C, D, Fig. 560) and continue kneading. The professional potter has a wire strung above his table and on it cuts his clay quickly and neatly in half, but a knife will answer very well. You may have a number of



Fig. 560.—Put the outside edges together.

### Modelling Tools

or a few, and you can do very well with two or three contrived by yourself. A wire tool like Fig. 561 is useful in cutting away the clay when the walls of a piece are too thick, but a wire hairpin answers the purpose almost as well. A wooden skewer, used by butchers for pinning meat, is also good for some purposes. In my



Fig. 561.—Useful in cutting the clay.

own work one summer, when far out of reach of modelling tools, I found use for a palette knife, the handle of an old spoon, a hairpin and a steel ink eraser with a curved blade. But best of all and most to be depended upon are the fingers, for these sensitive, flexible, natural tools can perform most of the work alone. Fig. 562 is a small jar made entirely with the hands, no tool of any kind, save the fingers, having been used in the modelling. You should have a good

### Strong Table,

one you have no fear of harming, and that stands firmly and evenly on the floor; a piece of smooth, rather thick board about

ten inches square upon which to build your pottery and a small pastry board. Place the table near a window where there is plenty of light and under it lay a piece of oilcloth to protect the floor; thus prepared you may plunge into your work and accomplish wonders without disturbing the general order of the room. At a convenient place on the table set a small bowl of water and a cup of slip. The slip is simply clay softened in water until it is about as thick as cream. A large piece of old muslin, that you can tear in pieces as needed, should always be at hand, and a wet sponge on which to wipe your fingers.

Place your pastry board on the table and when the clay is kneaded lay it to one side and scrape the board, clearing off all dried particles. Unless this precaution is taken crumbs of dry clay are apt to mix with the moist clay and make it rough and gritty.

Figs. 563, 564 and 565 are three original designs in candlesticks. We will take one of these for a model. Fig. 563 is the simplest and most easily made, so we will begin with that.

Have ready a rather deep

#### **China Saucer,**

tear off a square of muslin large enough to cover the inside of the saucer and to extend over its edge. Dip the muslin in the bowl of water and lay it flat in the saucer, pressing it down as evenly as possible and smoothing out the air bubbles.

Now take

#### **A Large Handful of Clay,**

roll it between your palms, lay it on the pastry board in front of you and with an even pressure of your hands roll it back and forth until it lengthens out and forms a snake-like piece a little

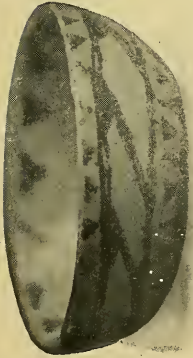

Fig. 576  
Design Painted on the Unbaked Clay.



Fig. 565  
A Leaf Design.



Fig. 575  
The Little Pitcher.



Fig. 503  
Yellow Candlestick.



Fig. 562  
Made Without Tools.



Fig. 564  
Hooded Cobra Design.



more than half an inch in diameter (Fig. 566). Do not let the roll flatten, keep it as round as possible and of an equal size from end to end, then press it with your fingers and flatten the top just enough to take off its roundness. When this is done place one end of the roll narrow side up exactly in the centre of the saucer and make

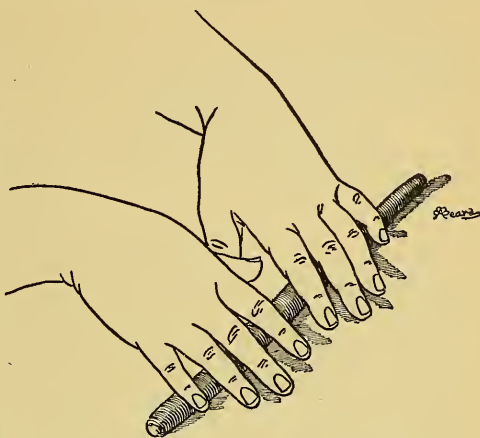

Fig. 566.—Roll the clay back and forth.

#### A Close Coil

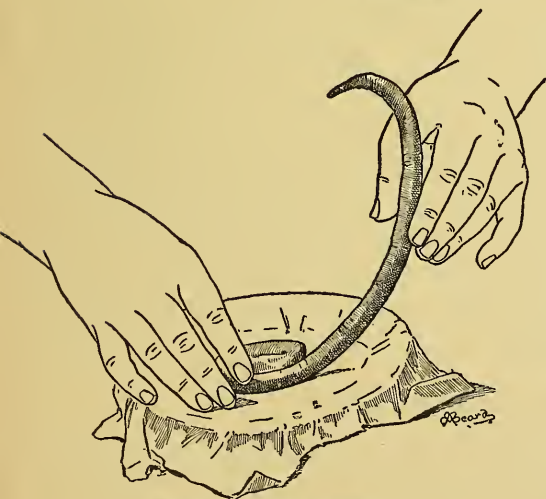

Fig. 567.—Make a close coil.

like Fig. 567, bringing the edges of the coils together with your thumb nail. When you have coiled one roll make another roll and, cutting the end of each, like Fig. 568, fit them together and make a smooth and even joint.

Continue to coil the clay until the saucer is filled to the edge, then build it up

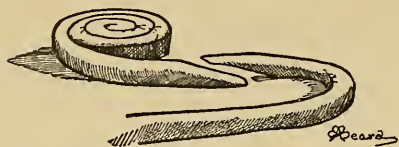

Fig. 568.—Cut the ends like this.

one coil higher on the edge and cut the last end of the roll as you did the first. Press this end down to join the roll beneath it, making the joint invisible. Now

### Dip Your Fingers in Water

and rub them gently over the coiled clay in the saucer to smooth it, but be careful not to get it too wet and not to lower the coil on the edge in the process. If depressions occur fill them with fresh clay joining the edges of the new clay to the coiled clay, making it one piece with no cracks or seams. In adding clay at any time the new piece must always become one with the old, else it will crack when dry or in the firing, and it is best to brush the place to be filled with slip before adding the clay. Set your saucer away at this stage of the work until the clay stiffens a little and the piece becomes what is called "set." It is just here that you must use patience, for to continue to work while the clay is too soft will frequently spoil the whole thing and the only remedy is to bunch the clay and begin over again. To be successful in the making of pottery one's enthusiasm must be of the kind that will not cool during the necessary waiting periods.

When the clay in your saucer has become firm but is still quite pliable, dip another square of muslin in water, spread it inside the clay saucer and

### Fit in Another Saucer

of china a trifle smaller than the first. This will give you a pile of three saucers one within the other, first china, then clay, then china. Now cover your small board with wet muslin and turn

your stack of saucers upside down on the board. Lift off the top saucer and you have your clay saucer inverted on top of the smaller china saucer. You will find all the seams of the coil showing on this underside and must join them and make the clay one piece as you did on the inside. With your wire tool (Fig. 561) or a hairpin, carefully

### **Cut Down the Parts**

that seem too thick, but at the same time beware of making them so thin as to weaken the walls of the saucer. It is better to fill out and make a piece rather heavy than to try at first to obtain the delicacy one naturally desires, for thin walls often collapse in unaccustomed hands. As you work, turn the board around and around to be sure the contour is symmetrical. It is often a good thing to raise the work to the level of the eye in order the better to detect inaccuracies of outline.

When you have finished the underside and the clay seems firm enough to stand without support, turn it right side up on the board, always with the wet muslin between to keep it from sticking. Lift out the small saucer which is still in the clay saucer and proceed to remove all traces of the line in the clay made by the ridge on the bottom of the china saucer. This can be done by smoothing down and adding more clay to make a curve instead of an angle.

With the wooden skewer make a dot in the centre of the clay saucer, measuring the distance to be sure it is exact, then take

### **A Half Candle,**

wrap it spirally and closely with a narrow strip of wet muslin (Fig. 569) and stand it directly over the mark (Fig. 570). Make little crossed lines with a sharp tool, or hat pin, around the candle

like Fig. 571; then roll some clay for coiling the candle holder, flattening the roll as you did for the saucer.

Before beginning to coil cover the roughened surface around the candle with slip, then press one sharpened end of the clay roll onto the saucer close to the candle

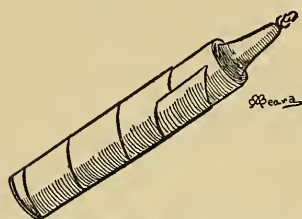

Fig. 569.—Wrap the candle with a strip of wet muslin.

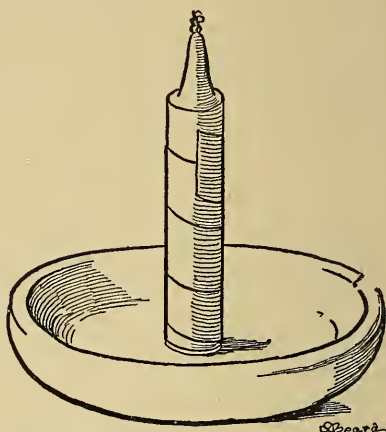

Fig. 570.—Stand the candle in the centre of the saucer.

(Fig. 572) and bring the roll once around the candle. Make crossed lines on top of the coil, brush with slip and coil again. Continue roughening the top of the coil and covering with slip until

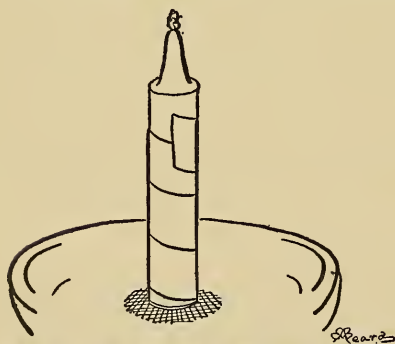

Fig. 571.—Make little crossed lines around the candle.

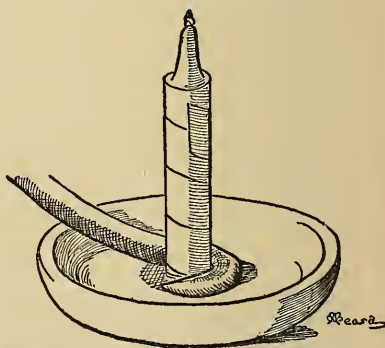

Fig. 572.—Press the sharpened end of the roll close to the candle.



you have built the holder up a little over two inches from the saucer, then sharpen the end of your roll and join it to the top (E, Fig. 573). With a brush dipped in slip, fill up, to some extent the creases between the coils and make the coil even and round where it may have been pressed out of shape, for in this part we allow the coil to show.

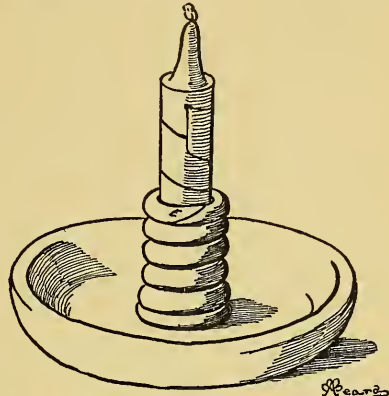

Fig. 573.—Sharpen the end of the roll and join it to the top.

When the walls of the holder are firm enough gently remove the candle and

### Smooth the Inside of the Holder

with a finger wet with slip. If this does not fill up the cracks use a rounded tool, but be very careful not to press the holder out of shape or enlarge the opening.

### Make the Handle

of a coil of clay as shown in Fig. 574. First the small coil, joining the base of the holder to the saucer, then the larger coil which connects the small coil, and the inside and the outside of the saucer. Use your first finger for keeping the hole in the centre of the large coil the proper size. Build up the edge of the saucer slantingly

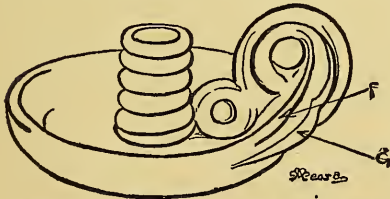

Fig. 574.—Make the handle of a coil of clay.

to join the inner coil of the handle (F, Fig. 574) and allow a ridge to extend from the outer coil a short distance along the outside of the saucer (G, Fig. 574).

#### **This Blending of Decoration with the Article**

itself, making it appear a natural outgrowth from it, is a law of beauty in modeled decoration, which should always be kept in mind. No part of a piece of pottery should look as if it were simply stuck on and might drop off again, but rather as though it were a necessary part of the whole.

When your candlestick is in good shape and still moist, go over it with a camel's-hair brush dipped in water, smoothing down any little unevenness in this way. Sometimes a coating of slip, well worked in with the brush will give a good surface. Set the piece away after this and let it stand undisturbed for several days, or until the clay has become quite dry and has turned almost white, then if it is still imperfect in shape

#### **Scrape it Down**

with a steel tool or pocket knife. The clay is so easily shaved off at this stage the danger lies in making too deep a cut and the work should be done gradually and patiently. For the final rubbing use a piece of fine emery paper. Even this must be carefully handled, for if pressed heavily on the clay it, also, will cut too deeply.

Do not put your work away to dry in the sun or near a fire. If dried too rapidly the clay will crack. Sometimes it will crack when it dries, never so gradually; it may be from shrinkage or because the clay has not been sufficiently kneaded.

#### **If Cracks Occur**

while the clay is still moist fill in with new clay and slip. If the piece is perfectly dry mix some finely powdered baked clay with

water, making a thick paste, and fill the opening. You may be able to get the unglazed baked clay at the pottery, but if not put a thin cake of clay in any kind of a very hot oven and allow it to bake several hours, then grind to a fine powder. Keep this powder in a labelled box that it may always be at hand when needed.

It is generally supposed that when a piece of pottery cracks in the firing there is no remedy. This is very likely true with pieces that have been glazed, but with unglazed ware my own experience has proved that it can be mended. When an unglazed piece comes from the firing showing cracks, large or small, mix a thin slip of clay with a little finely powdered flint and run into the cracks until they are more than filled, then rub or scrape off the surplus. This formula was given me by a prominent art potter who also furnished the mixture.

In putting away

#### **Unfinished Work,**

cover with a damp cloth and keep the cloth damp until you are ready to go on with your modeling. Once hard the clay can no longer be worked, and unfinished pottery must always be kept moist. In the case of a piece having handles, spouts and like projections, place something under the cloth to hold it away from these parts and prevent its pushing them out of shape.

#### **You May Glaze Your Candlestick**

with colored glaze before it is fired or you may have it fired and returned to you in "the bisque," when it can be glazed and sent to be fired the second time. One firing really seems all that is necessary for small pieces, however. Fig. 563 was fired but once, the glaze having been applied to the unbaked clay and

it came from the pottery in a perfectly satisfactory condition, without crack or blemish.

The glaze used for all the pottery in the little group in our full-page illustration, is Marshing's soft Limoges glaze which may be obtained where mineral colors for pottery and china painting are sold. The glaze is transparent when fired and is to be mixed with color unless the piece has underglaze decoration or the clay is colored. The proportion is one part dry color to nine parts dry glaze. Both come in powders and must be thoroughly mixed, then dissolved in a solution of gum arabic. Eight and one-half teaspoonfuls of glaze to one-half teaspoonful of underglaze color is sufficient for two candlesticks. Apply this with a No. 8 camel's-hair brush and give the piece three coats, waiting each time for one coat to become thoroughly dry before putting on the next. Lay the color on evenly and do not allow little streams of glaze to run over the edges.

There are various

### **Other Methods of Coloring Pottery**

One is to work the dry color into the moist clay by kneading. For the little pitcher (Fig. 575) one tablespoonful of raw sienna was thoroughly worked into a lump of clay the size of a large apple and the pitcher then modelled from the colored clay. Prepared mineral color was not used, but dry "raw or green" color purchased at an ordinary paint shop. When quite dry the pitcher turned a beautiful ivory yellow, but became almost terra cotta when fired. The uncolored glaze was dissolved in gum arabic and applied after the first firing, and the pitcher was fired a second time.

Another way to color your pottery is to mix the raw color with slip the consistency of cream and with it paint a design on the

unbaked clay. A little gum arabic added to the slip will make it adhere more closely and prevent its rubbing off. This must be fired before the uncolored glaze is applied. The little bowl (Fig. 576) was decorated in this way and the colors used were raw sienna and burnt sienna. But one coat of glaze was given the bowl which makes it look more like old Indian ware than if it had the very glossy surface.

Colored pottery

### **"In the Bisque"**

or unglazed state is often very beautiful and if designed to hold water or liquid of any kind the inside alone may be glazed, leaving the outside in its natural dull and porous condition.

Of the various designs shown here the saucers were used only for Fig. 563, and the sooner you are able to discard all such aids and depend upon your eye alone to guide your hands the more you will enjoy your work.

Probably you can have your candlesticks fired at the pottery where you get your clay, but if you wish to carry on the work and experiment for yourself secure a kiln of your own by all means.



*Beard*

The Light of the Fairy Lamp.

## CHAPTER XXXII

### WHAT TO MAKE OF BANANAS, ORANGES, AND APPLES



**W**HILE icy blasts are still sweeping through the cities of the North, while the snow lies deep on the ground, and the children, bundled up until little except their pink noses is visible, are coasting, sleighing, and snowballing, in the South soft breezes are sifting through the green leaves of the trees and gently stirring the beautiful flowers blossoming in the warm sunshine.

In the orange groves the great golden balls are ripening, and on the long-leaved banana trees hang the queer bunches of bananas, growing in their funny upside-down fashion. Pineapples, lemons and many other fruits are there, all growing and ripening that the children of the North may have them when their own delicious strawberries, peaches and plums have gone.

We are very glad of these Southern fruits, even the skins seem too good to throw away. And so they are.

#### **Save Your Orange, and Banana, and Apple Skins,**

too, and see what delightful things you can make of them.

Long, long ago, before there were any steamboats, sailboats or even rowboats in the British Isles, when men's clothes were

merely the skins of wild beasts tied on with leather thongs, the people went on the water in little circular boats called coracles. These boats were wickerwork baskets covered with the hides of animals and resembled bowls in shape. They were sent skimming over the water very rapidly by means of a paddle which was dipped in first on one side of the boat then on the other. The coracles were so small a man easily carried his boat on his back to transport it over dry land, looking, one would think, very much like a huge turtle walking on its hind legs.

It is a boat like this most primitive one that you can make of

### Half of an Orange Skin

It will float, too, and ride safely the roughest waves of the bath-tub sea. As it is perfectly water-tight, Miss Dolly need have no fear of wetting her dainty skirts as she sits in the bottom of the boat.



Fig. 577.—Cut an orange exactly in half.

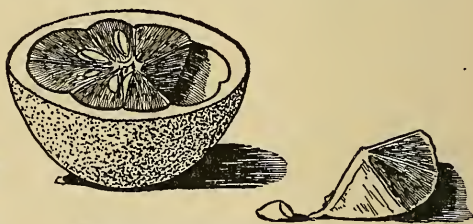

Fig. 578.—Carefully remove the pulp.

Cut an orange exactly in halves like Fig. 577. Slide the blade of a penknife around the edge, loosening the pulp from the skin, then cut the pulp in quarters and remove it piece by piece as in Fig. 578. When all is taken out you have your little boat (Fig. 579) and your orange besides.

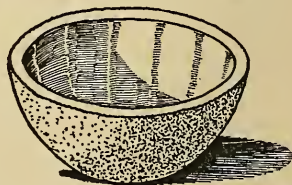

Fig. 579.—The coracle.

Place the coracle in a basinful of



water, put a small doll in it, stir the water round and round with a stick, and watch the boat glide along as swiftly as if its little occupant were paddling with all her might.

From the skin of the banana an almost

### Perfect Canoe

can be made, which will look very much like those used by the Indians at the time when Columbus discovered America. You know, of course, that a banana has several ridges on its surface



Fig. 580.—Make a slit with the point of your knife.

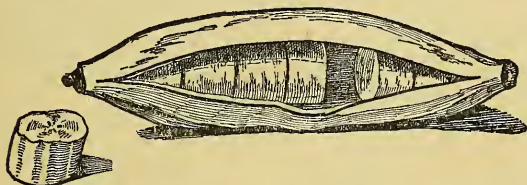

Fig. 581.—Take out one piece at a time.

with wide, smooth spaces between and that the stem end curves up more decidedly than the other. Along the middle of the smooth space which takes the upward curve of the stem you must make a slit with the sharp point of your knife, as shown by the black line on the banana in Fig. 580. Open the slit carefully, cut the banana in small pieces and take out one piece at a time (Fig. 581).

Cut the sulphur ends off two matches (Fig. 582) and place the little

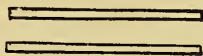

Fig. 582.—Cut the sulphur ends off two matches.

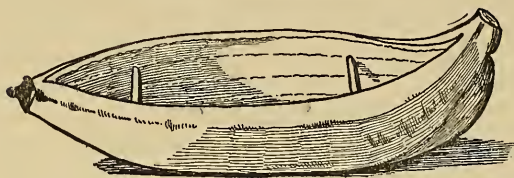

Fig. 583.—The little canoe.

as a seat for the doll-man (Fig. 584). Fig. 584 shows both the canoe and the coracle in the water.

sticks crosswise in the banana skin, one near each end, to act as braces in holding the sides apart (Fig. 583) and

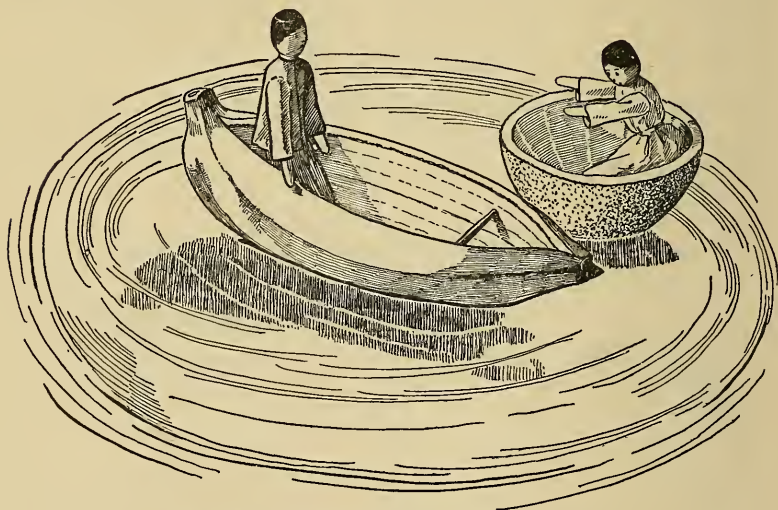

Fig. 584.—Banana canoe and orange-skin coracle.

In selecting a banana for the canoe choose a symmetrical or even-sided one, that it may not tip but sit squarely on the water. In case the banana is not perfect and the canoe does tip to one side, place in it a small weight and the balance will be regulated.

The apple lantern, or

### Fairy Lamp

(Fig. 585) requires a little more time and patience in its preparation than the boats, but it is not difficult to make. Find a rather small, perfectly round, red apple without bruise or blemish. Hold it in both hands and gently press it with your two thumbs, beginning close to the stem and gradually working down to the blossom end. Be careful not to break the skin, but press and press until every part is loosened and the apple feels pulpy like a grape—every part except the blossom; that holds fast because it is attached to the core.

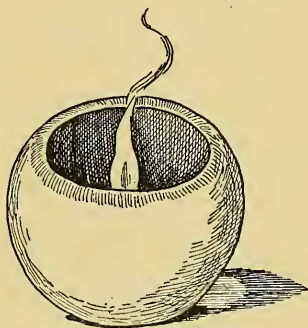

Fig. 585.—The fairy lamp.

When no hard spots can be found cut a circle around the stem as shown in Fig. 586, and little by little dig out the apple until nothing but the skin remains (Fig. 587); then you will find a

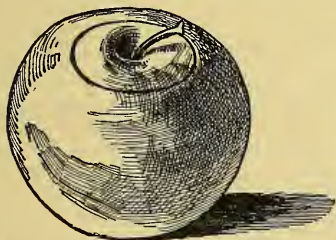

Fig. 586.—Cut a circle around the stem.

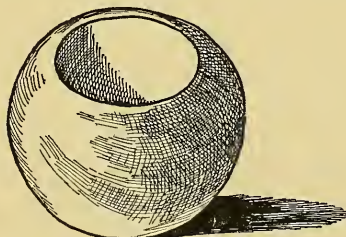

Fig. 587.—The empty skin.

small lump at the bottom which must be left, since cutting it out would result in a hole in the skin. With a pair of sharp scissors trim away all unevenness or raggedness that may be found on the edge. This will make the opening a trifle larger.

**Cut a Slice from an Ordinary Candle**

about half an inch thick (A, Fig. 588) and hollow out the under side enough to allow the candle to fit over the lump in the bottom



Fig. 588.—Cut the candle like these.

of the apple skin (B, Fig. 588). Fit the candle in place, and when it is lit you will have the prettiest, daintiest little fairy lamp imaginable. The light shining through the rosy, semi-transparent apple skin gives the effect of Bohemian glass and casts a red glow all around it.

The fairy lamp looks very pretty floating in water in a glass bowl, and a number of lamps around your birthday cake will be a new way of telling how old you are.

## CHAPTER XXXIII

### LITTLE PAPER COLUMBUS AND HIS PAPER SHIP



LACE a chair against one end of the bath tub, for Spain, and another chair at the other end of the tub for America. If the chair seat is lower than the rim of the tub, build up with books until the top book is as high as the tub; then fill the bathtub more than half full of water and pretend it is the Atlantic ocean. Cut out two paper dolls, one for King Ferdinand, the other for Queen Isabella.

Remember which chair is Spain, and seat the royal couple in Spain, on a throne, made of a bent piece of cardboard. Bring Columbus before the monarchs and let them bid him God-speed; then put Columbus in his ship, the *Santa Maria*, with a number of sailors, and send the vessel sailing off on her voyage of discovery. Gently push the boat forward by the projecting spar at the stern, and the little craft will sail along like a real ship on a real ocean; but you must be careful not to push too hard and capsize the vessel. When the boat reaches America, have ready on the chair at that end of the bathtub, some wild Indians with their wigwams, and let Columbus and his men land, while the Indians stand gazing at them in astonishment.

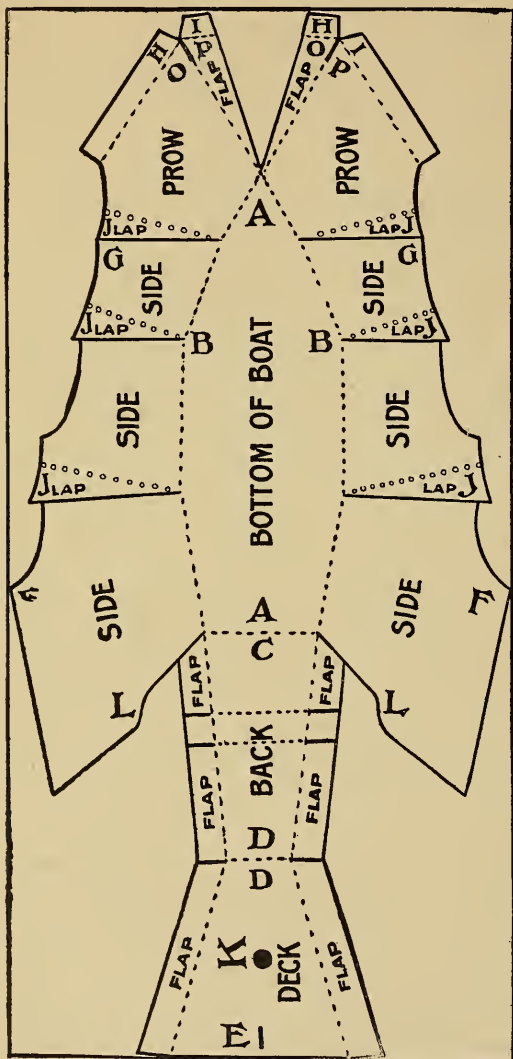
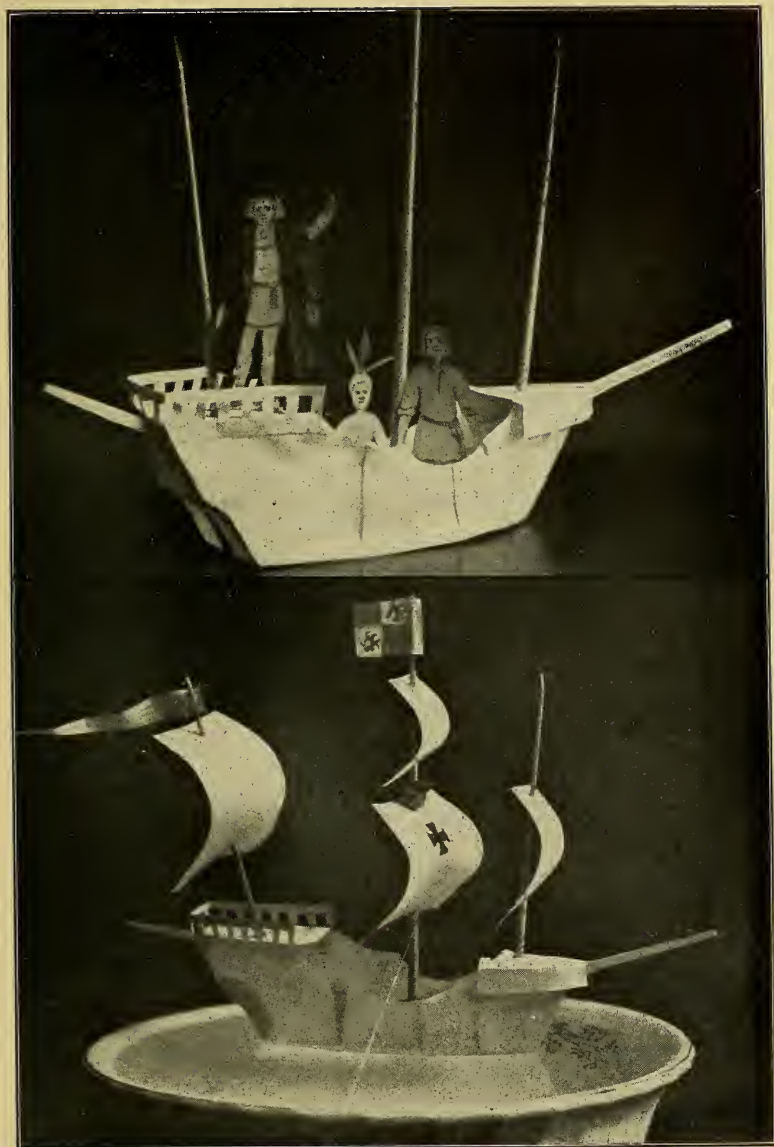

Fig. 589.—The hull of the *Santa Maria*.

Before we make the little paper people, let us build

### Columbus' Ship.

This ship is to be as nearly like the *Santa Maria*, the real ship in which Columbus sailed, as is possible to make of paper. Cut a piece of light-weight cardboard fifteen and three-fourths inches long and seven and one-half inches wide; on this draw the diagram of the boat (Fig. 589), making the greatest lengths of the diagram exactly as long and the greatest widths as wide as the cardboard. Find the lengthwise centre of the cardboard, which will be three and three-fourths inches from each



Columbus' Ship Made of Paper.





long side line, as the cardboard is seven and one-half inches wide. Draw a line along the centre from end to end, to guide you in making the diagram of the boat; this central line will also be the centre of your ship. Commence drawing the bottom A—A (Fig, 589) at a distance of two and one-fourth inches from the end of the cardboard; the bottom must measure seven inches from its extreme front point A to the back line A, and two and three-eighths inches at its widest point from B to B. The point A of the bottom must come on the long central line, and the straight back line of the bottom A must be one and three-fourths inches across.

The length of the extension at the back of the boat from C to D is three and one-half inches; the deck from D to E, three inches. The greatest width of the deck, E, not including the two flaps, is two and three-fourth inches, and the narrowest part at the line D one inch. The sides of the boat are slashed and the last slash or side piece, F, at its greatest height touches the edge of the cardboard, while the side pieces G and G, are the lowest, and so are the longest distance from the cardboard edge. When you have drawn the diagram cut out the little craft.

Cut along all the heavy lines. Bend the four dotted lines of the prow ledge (H, I and H, I) backward. All other dotted lines must be bent forward, and care taken to keep the bends exactly on the dotted lines. Do not bend the laps enclosed by the tiny circles along the sides J, J, J, J, J, J. These circles merely show how far the slashed sides lap over each other to form the correct shape of the *Santa Maria*, for you must know that Columbus' vessel was very different in build and appearance from any ships we find at the present time. The prow and stern were much higher than the middle of the boat and at the top the stern was quite narrow while at the bottom it was



Fig. 590.—This is the mizzenmast.

wide, making the rear of the ship big at the bottom and small at the top.

Now put the little craft together. Bend the sides up and fasten each lap on the edge of the next side piece with glue or strong, thick paste. Bend up the back and paste the three laps of each edge over onto the sides, fitting the short laps on the section K over the projections L and L of the sides.

### Make the Mizzenmast

of a paper lighter, ten inches high after the end has been bent (Fig. 590). Slide the small end of the mast, from beneath, up through the hole K in the after deck (Fig. 589). The hole should be a tight fit. Paste the bent end of the mast flat and tight to the bottom of the boat; bring the flaps of the deck down over the top of the sides and paste them securely in place.

Next bend up the prow, lapping the flap O (Fig. 589) over the side edge of the prow, O, and the flap P over the prow, P.

### Cut the Bowsprit

(Fig. 591) of cardboard six and one-half inches long, split the wide end up lengthwise through the centre two and one-fourth inches, then fold the remainder lengthwise through the centre according to the dotted lines



Fig. 591.—Cut the bowsprit like this.

Fig. 592. Open the split end and place one-half on the inside of one side of the prow, and the second half opposite on the inside of the other side of the prow. Leave these ends loose, resting the bowsprit in the short opening at the centre top of the point of the prow, where the two short ledges, H and I (Fig. 589), meet.

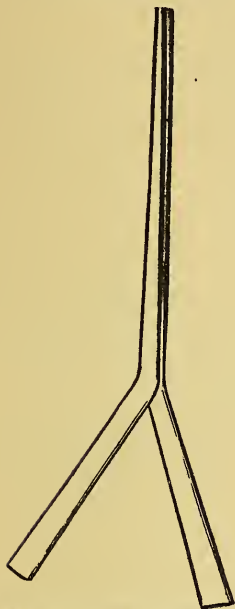

Fig. 592.—The bowsprit is folded through the centre.



Fig. 593.—The forward deck.

### Make the forward Deck

of cardboard (Fig. 593) two and one-fourth inches long and at its widest part a generous one and one-eighth inch. Cut the hole N, five-eighths of an inch from the wide, straight edge; then cut a strip five and five-eighths inches in length and three-fourths of an inch in width, slash as in diagram and bend at dotted line (Fig. 594). Cut the slit M, and fasten the strip on the deck by pasting the flaps over the top of the curved edge of the deck (Fig. 595). Slide the flat point of the projecting bowsprit through the slit M (Fig. 594), and



Fig. 594.—Slash the strip for the forward deck.

run a paper lighter foremast, nine and one-half inches long, not including the bent end, through the hole N (Fig. 593). Bring

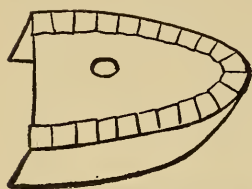

Fig. 595.—Forward deck.

the deck down over the prow, adjust the bowsprit to the inclined height of the bowsprit in the illustration and paste the two split halves of the end of the bowsprit on each side of the inside of the prow. Fasten the foremast tight on the bottom of the boat and paste the deck on the ledges,

H, I, H, I (Fig. 589). Make a

### Deck-Fence

for the stern of a piece of paper seven and one-half inches long and one inch wide. Cut it in a fringe with every other short strip of the fringe cut out like Fig. 596. Paste the loose fringe



Fig. 596.—The deck fence.

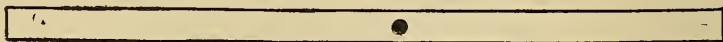

Fig. 597.—Strip for bottom of fence.

ends along the three outside top edges of the after deck, allowing the solid border of the fringe to form the fence rail. See illustration. Cover the lower ends of the fence when they are pasted to the deck with a band of paper seven and one-half inches long and three-eighths of an inch wide (Fig. 597).

### Make a Spar

for the stern of the boat as you made the bowsprit Fig. 592, only the spar should be shorter, extending beyond the stern of the boat about two inches. Slide the large end of the spar through

the opening in the deck at E (Fig. 589) and rest the split ends on each side of the mast.

### For the Mainmast

at the centre of the boat make another paper lighter eleven inches high. Do not bend the end, but paste the bottom lapped edges together and run the mast through a common wooden spool (Fig. 598). Glue the spool tight on the bottom of the boat, a trifle forward of the centre, and your ship is ready for the sails, as you can see from the picture.



Fig. 598.—Support the mainmast with a spool.

The illustration shows little paper Columbus in his red cloak and cap, standing on the stern of his vessel, one of the sailors in the centre, and a wild Indian peeping over the side of the boat. We must make our

### Santa Maria Watertight

before the sails are set. Melt half of a wax candle in a tin piepan and set the ship down into the melted hot wax to cover the bottom thoroughly. Use a teaspoon for pouring the liquid wax over all sides, about one inch up from the bottom of the boat. This bath of wax should render your ship perfectly watertight, but test the little craft on water to make sure that it does not leak.

### Cut the Sails

of very light-weight writing-paper, the top edge straight, side edges slanting, and bottom edge curved inward. Make the greatest height of the foresail for the bow four inches, the width three and one-half inches. With the scissors point, punch two small holes in this foresail, one in the middle at the top and one

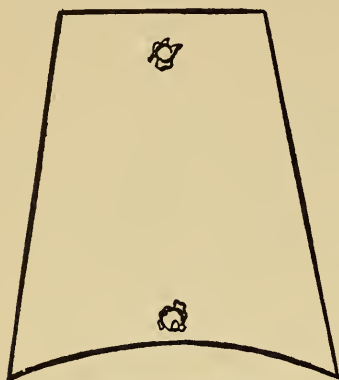

Fig. 599.—The foresail.

in the middle at the bottom. Enlarge the holes slightly by inserting the point of a lead pencil and twisting the pencil gently around (Fig. 599). Remember that all holes for the masts to run through must be made rather small, to prevent the sails from sliding too far down the masts. Bend the top and bottom of the sails together to curve the paper, that the sails may appear to be in a good stiff breeze

when fastened on the masts. Slide the foresail you have just made on the foremast; it will stay in place without glue. Make

### A Paper Flag

like Fig. 600, for the mainmast, one and three-fourths inches long and one and one-half inches wide. Cut two holes at one side as shown in the diagram, divide the remaining space into four squares and paint the two diagonal squares, Q and Q, red.

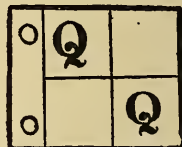

Fig. 600.—The flag.

like Fig. 601, for the mainmast, one and three-fourths inches long and one and one-half inches wide. Cut two holes at one side as shown in the diagram, divide the remaining space into four squares and paint the two diagonal squares, Q and Q, red.

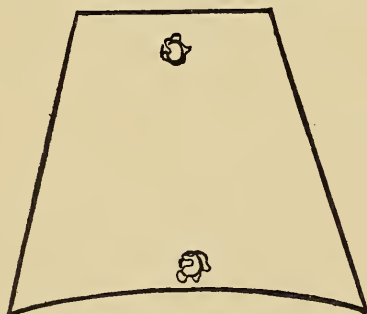

Fig. 601.—The main-topsail.

### Make the Main-Topsail

three and one-fourth inches long and three and three-fourths inches wide (Fig. 601). For the

### Crow's-Nest

saw or cut off the top of an ordinary wooden spool and paint



Fig. 602.—The  
crow's-nest.

red downward points around the top edge, a pointed band around the centre, and two straight, narrow bands at the lower edge (Fig. 602).

### The Mainsail

(Fig. 603) must be four and one-half inches long and five inches wide. Paint a red cross on it as shown in the diagram. Slide the main-



Fig. 603.—The mainsail.

sail well down on the mainmast; over it place the spool top "crow's-nest"; next run on the main-topsail and slip the flag on the tiptop.

### The Jigger Sail

for the mizzenmast at the stern of the boat must be five inches high and five inches wide (Fig. 604). Paint the paper pennant (Fig. 605) blue, and bend it into several waves. Slide the jigger sail in place on the mizzenmast and top it with the blue pennant. Your fin-

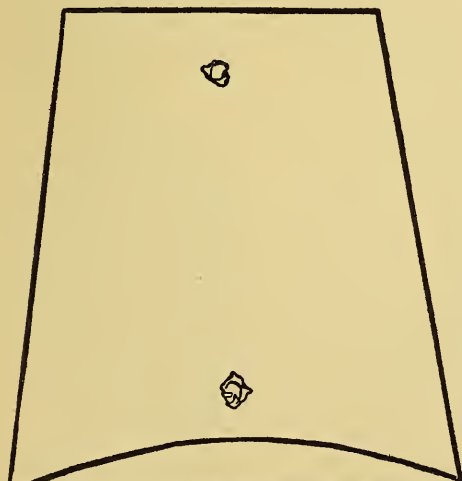

Fig. 604.—The jigger sail is shaped like this.

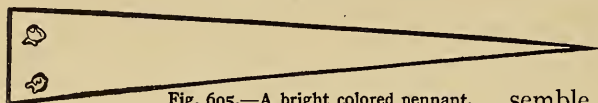

Fig. 605.—A bright colored pennant.

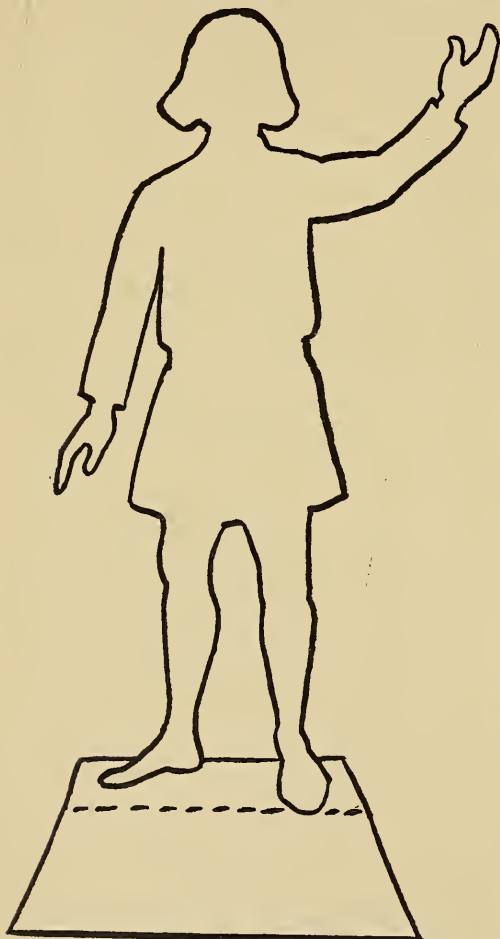

Fig. 606.—Cut Columbus out by this pattern.

ished vessel should resemble closely the illustration. If you want to

### Paint the Santa Maria

do so before giving it the wax bath. Color the hull a reddish brown, the masts brown, and the sails a light orange; this will give a very pretty effect.

Now for the characters of our little drama. Make

### Columbus

of heavy stiff writing-paper or very lightweight cardboard, like the pattern (Fig. 606), which measures from the top of the head to the lowest edge of the stand, four and three-fourths inches. Without the stand the



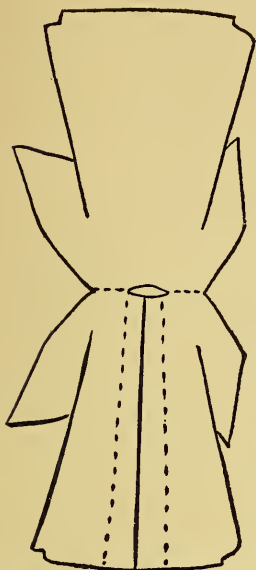

Fig. 607.—Make a cloak for Columbus in this way.

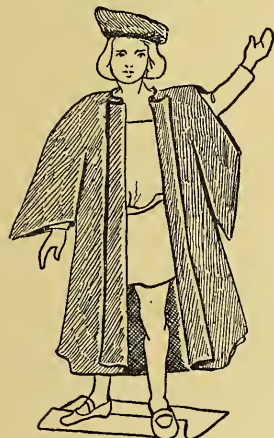

Fig. 611.—Columbus in his red cloak.



Fig. 608.—Turn back the front edges.



Fig. 609.—Cut the hat like this.



Fig. 610.—The hat is folded.

figure measures four inches. Carefully cut out Columbus, mark his features, hair, and clothing in black ink. Cut his cloak (Fig. 607) of red tissue paper, bend at dotted lines across the shoulders, and fold back the open front as in Fig. 608.

Make the red tissue paper cap (Fig. 609), and fold lengthwise across centre (Fig. 610); then put both cloak and hat on Columbus, that he may be ready to start on his journey (Fig. 611). Cut out

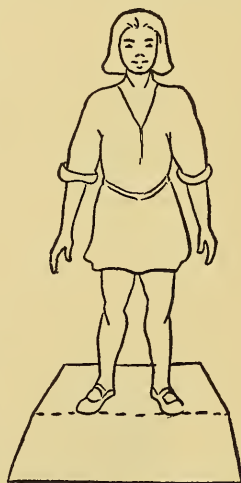

a number of Fig. 612.—One of the sailors,

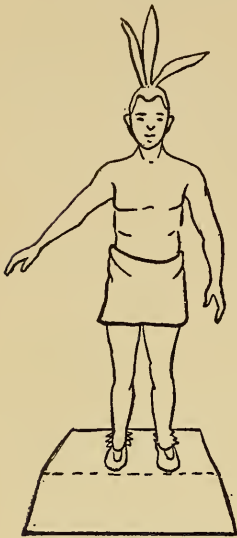

Fig. 613.—The Indian.

sailors (Fig. 612) to go on the boat with Columbus, and a lot of Indians (Fig. 613) for Columbus to find when he lands on the shores of America, at the other end of the bathtub.

### Make Wigwams

for the Indians of paper cut in half circles. Bend back narrow, pie-shaped pieces along the two straight edges of each half circle, make the pie-shaped pieces reach midway up toward the centre; then bend the half circles into tent-like forms, pin the two top edges of each one together, and you will have wigwams, with the doorway flaps bent back. Cut off the top peak of each,

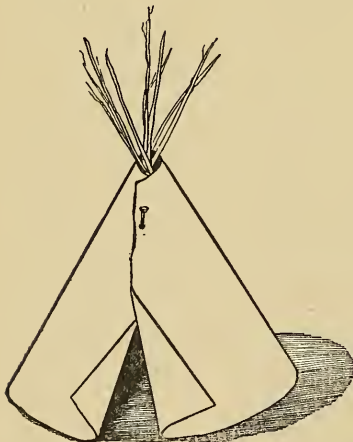

Fig. 614.—Make several paper wigwams.

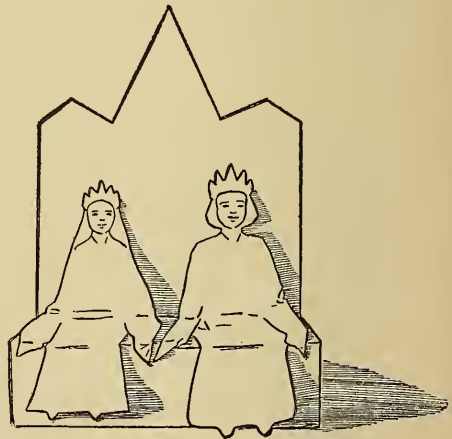

Fig. 615.—King Ferdinand and Queen Isabella.

wigwam and stand some heavy long broom straws in the opening to represent poles used in real wigwams (Fig. 614).

Fig. 615 shows

**King Ferdinand and Queen Isabella**

of Spain, seated on their pasteboard throne, ready to receive Columbus.

Queen Isabella gave three ships to Columbus, but the *Santa Maria* was the largest vessel, and the one which carried Columbus. The two smaller boats were named the *Pinta* and the *Nina*. You can make these smaller ships or use any little boats you happen to have; they are not very important.

## CHAPTER XXXIV

### HOW TO MAKE FRIENDS WITH THE STARS

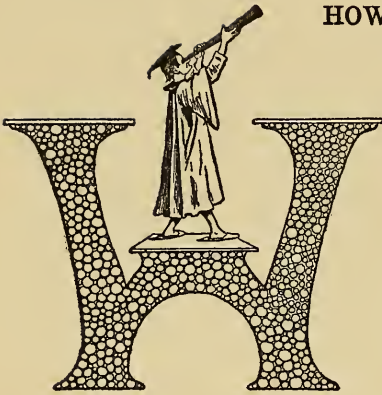

WHEN you used to recite about the cow jumping over the moon, you did not know that there were all sorts of animals and people up among the stars near the moon, and, while they may never have followed the example of the cow in the nursery rhyme, probably they often feel as though they would enjoy doing so. But these starry people and their pets are very well behaved, and so far they have been perfectly content to remain exactly where they were placed hundreds of years ago.

There is one animal in particular with which you must make friends—a bear, an immense creature called

#### Ursa Major

Never could an earthly bear have such a tail as you see in Fig. 616. However, the Great Bear is very different from the ordinary bear, and needs the big, bushy tail for three bright stars. Four more equally bright stars are on the creature's side. Trace the big bear on cardboard, and be sure to get the stars in the

right places. Cut out the pasteboard bear, and with a large, coarse pin or needle pierce a hole in the centre of each star; then hold the bear up to the light, as the little girl holds the lion in Fig. 617. Look through the bear and you will see seven tiny, twinkling stars forming a dipper. Pretend you have stretched a



Fig. 616.—Ursa Major, the Great Bear.

string from star to star, and what you will see will resemble Fig. 618. Look again and if the dipper is not distinct, make the holes in the centres of the stars larger.

After you have learned precisely how Ursa Major looks with its starry dipper, and can see it even with your eyes closed, peep out into the night and try to find your friend up in the real sky. The bear is there, but you must recognize it by the dipper, for of course you cannot really see the animal itself. When you find the dipper you will know that the Great Bear is in the sky looking down upon you. You can see the big bear during the early evening hours of March, April, May, June and July.



Fig. 617.—Making friends with the stars.



Fig. 620.—Ursa Minor, Little Bear.

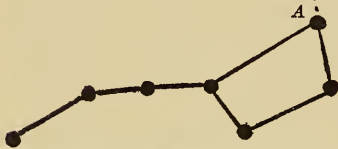

Fig. 618.—Ursa Major, Great Bear.

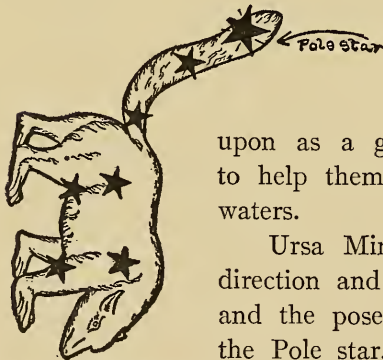

Fig. 619.—Ursa Minor, Little Bear.

Fig. 619 gives another bear, a little one, whose name is

**Ursa Minor;**

he also has a long tail spangled with stars and four more stars on the side of his body which form a little dipper; the three stars on the tail make the handle. Though the bear is small, he is very important because of the large star on the end of his tail, which you must call the Pole star. This star shines out to show which

direction is north when one gets lost or confused about his way. The Pole star may always be depended

upon as a guide, and sailors look for it to help them find their course through the waters.

Ursa Minor is turned in an opposite direction and position from the Great Bear, and the pose makes it easy for us to find the Pole star, because when we once trace out the stars of the Great Bear in the real sky we will see that the two outermost stars of the four which form its bowl, point to the Pole star. We can pretend that we have tied a string on the star in the outside top end of the Big Dipper (Figs. 616 and 618 A),

and that we are stretching that string out from the Dipper star in a direct line; then we can tie the string on the Pole star in the end of the Little Bear's tail, as shown in Figs. 618 and 620, where the dotted line represents a string.

Trace on cardboard and cut out Ursa Minor, punch holes through the stars and hold the little fellow up to the light, head down. The Little Bear, too, is visible shining not far from the Big Bear during the same months.

There is

### A Fairy Tale

about the starry bears. The story tells us that a long time ago these animals were not bears and did not live among the stars. The Great Bear was a gentle lady, and the Little Bear her son. The poor mother and son were turned into bears by the goddess Juno, and their friend Jupiter had not enough power to disenchant them and restore to them their human forms. So he did what he thought was next best; he placed the two bears, mother and son, up in the sky among the stars, where they remain to this day.

Fig. 621 is

### Cassiopeia

In the sky all of her stars are brilliant, except the one marked K. This is a shy little twinkler and appears rather faint at times; but in the Autumn when you hunt for Cassiopeia, you will be able to see the star K, if your eyes are bright. This lady with up-lifted arms is the wife of a king. Trace her and cut her out, punch



Fig. 621.—Cassiopeia.

holes through the centres of the seven stars, then catch hold of the sweeping train of the queen's dress and hold her up to the light, when the pinholes will look like Fig. 622,

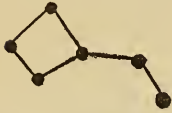

Fig. 622.—Cassiopeia.

reminding one of a chair turned upside down, with its feet toward the queen's head and its back down toward her feet. You will be delighted with this constellation, for it is very beautiful, and you may find Cassiopeia any night of August, September, October, November, December, January and February, as she is always then visible after dark.

Now we will make the king of beasts,

### Leo, the Lion,

for he is very fine-looking with his starry mane and a star almost in his mouth (Fig. 623). Trace the lion carefully, name him Leo, and cut him out; pierce holes through the stars and hold the figure up to the light. The little girl in Fig. 617 is enjoying her Leo very much. Notice how earnestly she peers through the holes, for she is determined to know the constellation.



Fig. 623.—Leo, the Lion.



Fig. 624.—Leo, the Lion.

When you look through the pinholes of Leo, you will find that the constellation resembles a sickle, as in Fig. 624. The lion is in plain sight during



February, March, April, May and June, so you have a long time to make friends with him.

During the Spring you can see all the constellations we have made, and also the beautiful starry

### Northern Crown

(Fig. 625), shining in a brilliant half circle as shown in Fig. 626. The gems of stars in the crown sparkle and shine for us during April, May, June, July, August, September and October.

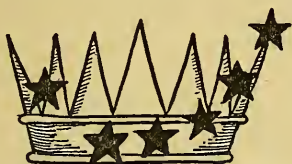

Fig. 625.—The Northern Crown.



Fig. 626.—The Northern Crown.

The little twin brothers,

### Castor and Pollux,

sons of Jupiter; always sit together up among the stars. The constellation is called Gemini (Fig. 627). When stars are clustered together, we say the group is a constellation. All of the starry people and animals are only different constellations. In this group each boy has a star on his head, a star on one knee and a star on



Fig. 627.—Gemini, the Twins.



Fig. 628.—Gemini, the Twins.

one foot, which makes six stars. Trace the twins on cardboard, cut them out together in one piece and punch a hole through the centre of each star. Hold the constellation up to the light, and the group of wee, sparkling stars seen through the pinholes will resemble Fig. 628. Look for the twins during the months of December, January, February, March, April and May, and remember you must find the group of stars like Fig. 628.

Winter will bring

### Orion

(Fig. 629). He appears in November and remains where we can see him through December, January, February and March. Orion is one of the most brilliant of constellations. The strenuous hunter has but one visible foot, the other being hidden by his pet hare seated in front of it; so we are obliged to make the star man with one foot. The fairy tale says that he was a giant and the mightiest hunter ever known. There is a star on each of his shoulders



Fig. 630.—Orion, the Giant.

and one on his cheek, forming a triangle; then there is another star down on his left foot and one on his right knee. Trace the mighty hunter and cut him out as you did the other



Fig. 629.—Orion, the Giant.

constellations. Draw a line from star to star and, after adding the three stars which form Orion's belt, pierce holes in all, look through them (Fig. 630) and make friends with the harmless, starry giant. Fig. 631 is

### Taurus,

a very lively-looking bull for one so aged; possibly the stars, being bright and cheery, keep the milk-white creature from growing old. Only a portion of the bull can be seen; other stars hide the remainder. Taurus must be greatly dazzled by the



Fig. 631.—Taurus, the Bull.

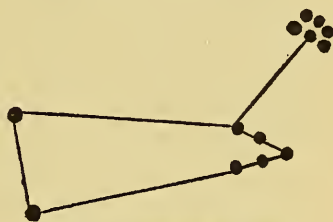

Fig. 632.—Taurus, the Bull.

stars, for there is actually one in each of his eyes, the two forming the ends of the V-shaped group of stars across his face. The tip of each horn is decked with a glorious star, while on the Bull's neck is a cluster of stars called the Pleiades. These stars were in all seven beautiful sisters, daughters of the giant Atlas; but one star daughter married a mortal and lost her brightness for doing so; consequently you can now see but six star sisters.

In Fig. 632 you will find the constellation of Taurus as it looks when seen through the pinholes in the stars of the Bull, and also as the constellation appears in the sky on a clear night during November, December, January, February and March.

## CHAPTER XXXV

### STENCIL PAINTING AND HOW TO MAKE THE STENCILS

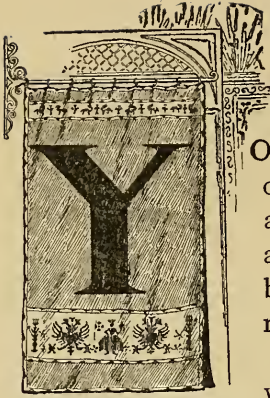

YOU need not be an artist to do the painting or to make the stencils. It is all easy enough and, because of the real beauty of the work and the number of purposes to which it may be applied, stencilling is growing more and more popular.

With the stencil you can decorate a window curtain, portière, table cover, bed-spread, bureau scarf, screen or the walls of your room. You may even paint the trimmings for a dress if you like; it has been done.

Stencilling is effective on almost any material: silk, cotton, linen and wool. Swiss and cheese-cloth sash curtains are particularly attractive decorated in this way, and swiss bureau and pin-cushion covers are very dainty. The drawing on page 427 is of a white cheese-cloth short sash curtain stencilled in pink and light apple-green. Both dye and oil paints may be used, but for anything washable

#### Dyes

are the best, inasmuch as they are supposed to be fast colors. There is an inexpensive dye now on the market that comes in tubes like oil paint and does not require boiling. This is convenient to handle, as it is merely necessary to dissolve it in water.

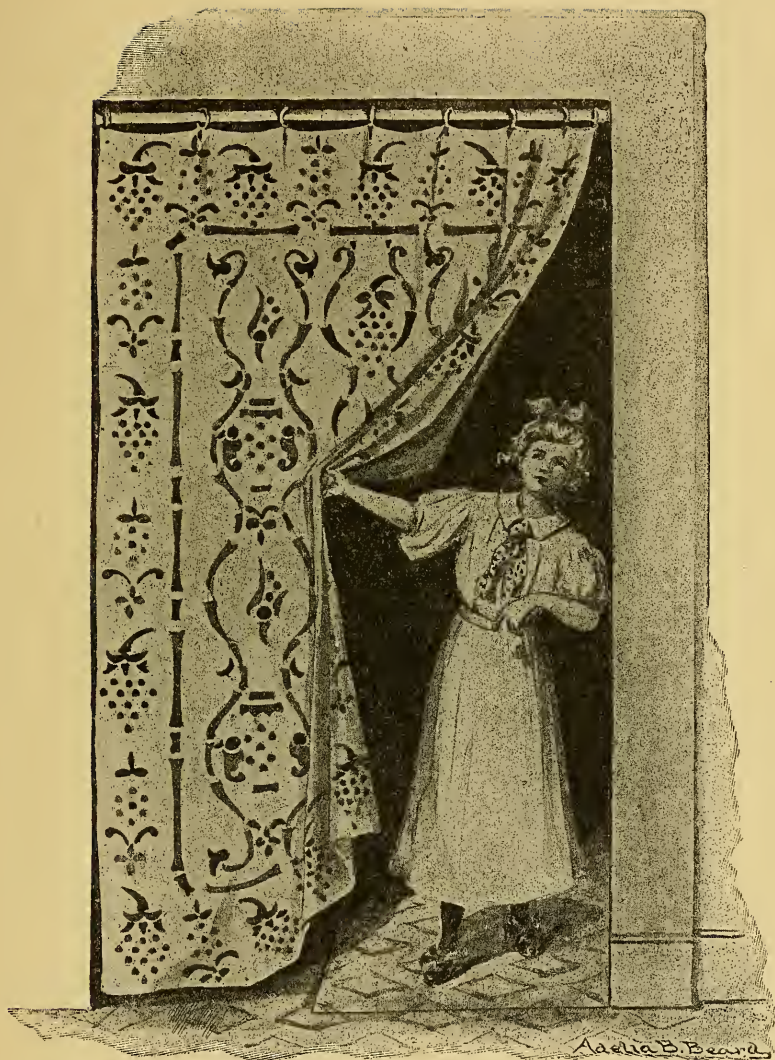

This Portière is Made of Unbleached Sheeting Stencilled in Persian Design.



Tapestry dyes may also be used but are much more expensive. Heavy, non-washable material may be stencilled with oil colors. The color is not used as a paint but as a stain and must be en-

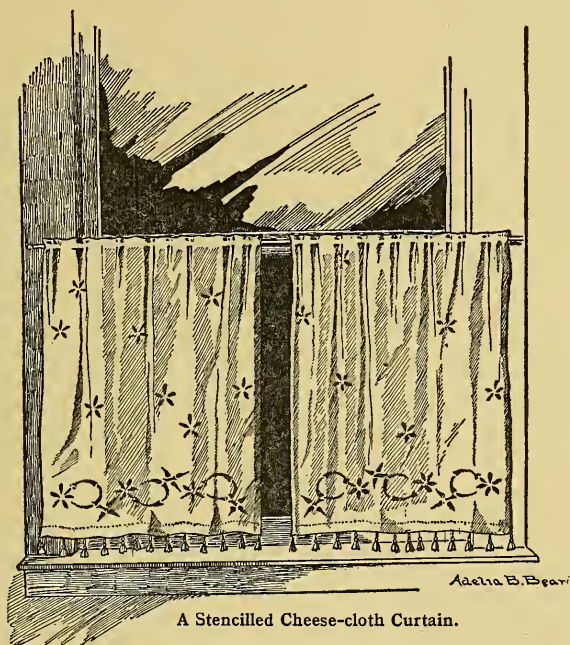

tirely dissolved in turpentine to make it flow easily. Our first drawing shows

### A Portière

made of heavy unbleached sheeting stencilled in a Persian pattern with dull-red, moss-green, yellow and black. Curtains may also be made of denim, crash, burlap and a number of other materials. The simplest way to

### Make Your Stencil

if you have no especial ideas of your own to carry out, will be to select a graceful embroidery pattern or one intended for decorative painting and adapt it to your use. With a little practice this becomes quite easy. The principal things to remember are that a good stencil design should be simple, bold and conventional; the unbroken lines must not be too long nor the spaces to be cut out too narrow, between the cut-out parts there must be space wide enough to hold firmly. It is also necessary to break the lines once in a while with little bridges.

Suppose we take the pattern (Fig. 633). To make it into

#### A Design for Stencilling

we must cut off connections and separate it into many parts, at the same time keeping the effect of the long curves. Beginning with the flower we will separate the petals and calyx (A, Fig. 633,



Fig. 633.—Design for outline embroidery.

and A, Fig. 634), and widen the stem (B, Fig. 633, and B, Fig. 634). Instead of continuing the curve we will break it at C and D, with two little bridges. This divides the stem into three parts, and, to give variety and interest to an otherwise monotonous line, we will widen the first and second parts of the stem at the



lower ends, curving the wide end inward and rounding the end of the next section to give the idea of its fitting the joint. The suggestion of the various parts fitting together in stencil designing is the means of carrying the eye over necessary bridges or intervening spaces and conveying the impression of continuous lines. The third section of the stem, where it disappears under the flower in Fig. 633, we will bring to a point in Fig. 634 to indicate its vanishing behind the flower. The buds which fill



Fig. 634.—This is adapted from an outline embroidery design.

in the curve of this stem in Fig. 633 we will leave out altogether, for they would crowd the design. We will conventionalize the leaves, dispense with the small stems, broaden the main leaf stem, separate it from the flower stem and curve each end, one to fit the base of the end leaf, the other to follow the curve of the flower stem.

This furnishes one section of the pattern; the rest is but a repetition of the same, which is reversed as the curves alternate.

Now for the making of the stencil.

Fig. 635 is a section of the design, actual size, which you can use immediately, without waiting to develop a design for yourself.

Take a piece of smooth white tissue paper, lay it over the pattern (Fig. 635) and, with a very soft lead pencil, trace the pattern carefully. Fig. 635 is reversed, especially for tracing. Have ready a perfectly smooth piece of heavy Manila wrapping paper seventeen inches long and seven inches wide. With the aid of a



Fig. 635.—Trace this.

ruler draw two straight lines lengthwise across the paper, the first line two and a half inches from the top edge of the paper (E, Fig. 636), the next one and three-eighths inches below the first line (F). One-half of an inch above the first line E draw another line (G), and one-half of an inch below the line F draw another line (H).

Lay the tracing, pencilled side down, on the wrapping paper, with the upper and lower curves of the flower stem just fitting between the lines G and F (Fig. 637). Transfer the tracing to

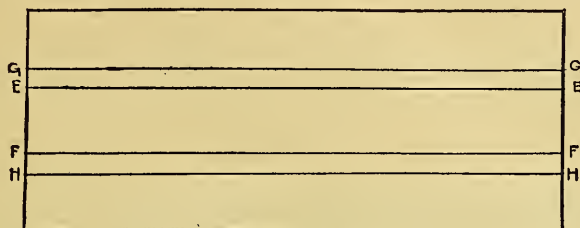

Fig. 636.—Rule the paper in this way.

the wrapping paper by going over the lines of the design with your soft pencil; then turn the tracing over and bottom edge up to reverse it and lay it again on the paper, this time with the

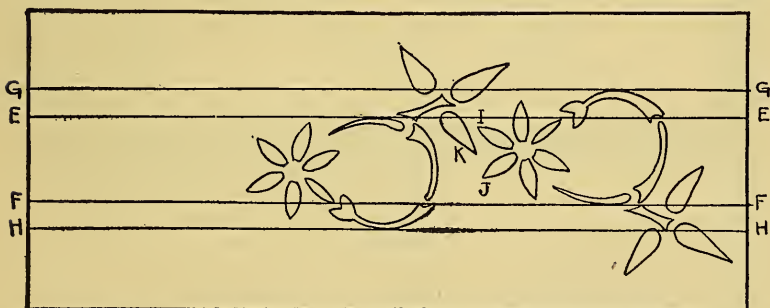

Fig. 637.—Place sections of the design between the lines in this way.

curves of the flower stem between the lines E and H, and go over the lines of the design again with your soft pencil. Once more reverse the design and bring the curves of the flower stem between the lines G and F. This last section will finish the pattern. In reversing the tracing always allow one-quarter of

an inch space between the tips of the two flower petals I and J (Fig. 637), and the leaf K (Fig. 637).

With a pair of sharp scissors

### Cut Out Your Design

taking great care to keep within the outlines, for a snip beyond will let in color in the wrong place and spoil your stencil. Remember you are not to cut the paper *away* from the design but cut

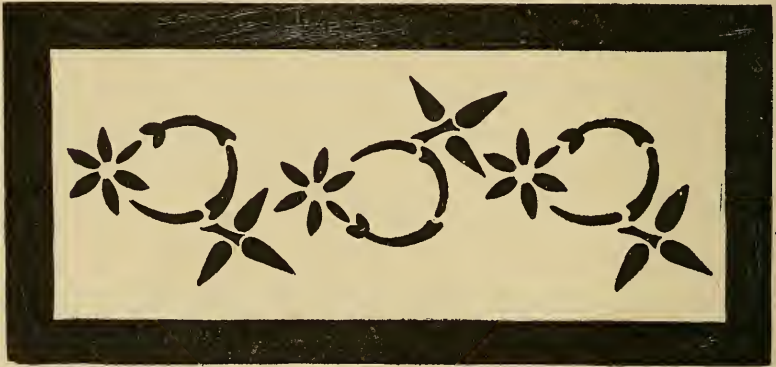

Fig. 638.—Cut the stencil out like this.

*the design out* leaving the surrounding paper intact. This makes the stencil (Fig. 638). When all of the design is cut out place your stencil flat on a board and give it a coat of white shellac, then lift it and move to another place on the board to prevent its sticking. When quite dry turn the stencil over and shellac the other side. Be sure the edges of the cut-out parts are covered with shellac as well as the rest of the paper. The shellac makes the paper waterproof and durable. Do not use the stencil until it is absolutely dry.

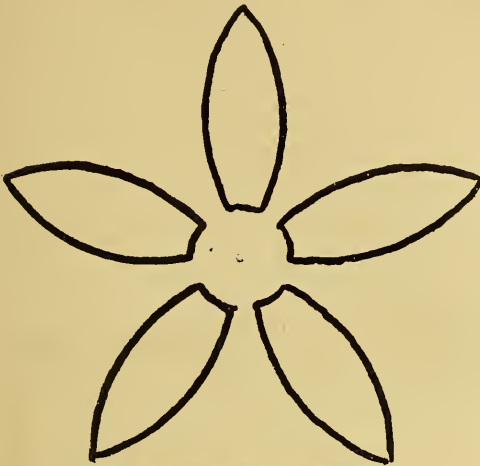

Fig. 639.—Trace this flower.

Trace Fig. 639 which is the conventionalized flower, and transfer it to the centre of a four-inch square of the wrapping paper, or make the flower smaller if you prefer to have it the size of the one in the border. Cut out the design and shellac the little stencil as you did the larger one (Fig. 640).

The closer the weave of the cloth the easier is the work of stencilling, but the dye penetrates entirely through thin material, and the effect is so attractive I will describe the

### **Cheese-cloth Curtains**

and the process given for stencilling these will answer for any other material.

One width of cheese-cloth for each half of the short Dutch curtains is sufficient for quite a wide window. If the curtain is too full much of the effect of the decoration is lost.

Select the finest quality of



Fig. 640.—The small stencil.

cheese-cloth and cut it the required length. Hem the bottom edge and lay the curtain, right side up, smoothly on a lap-board with the hem at the top. Place your stencil on the curtain so that the design will be about one inch and a half from the hem. Slide a new piece of blotter paper under the curtain to absorb the extra moisture, then tack the stencil down with rather small

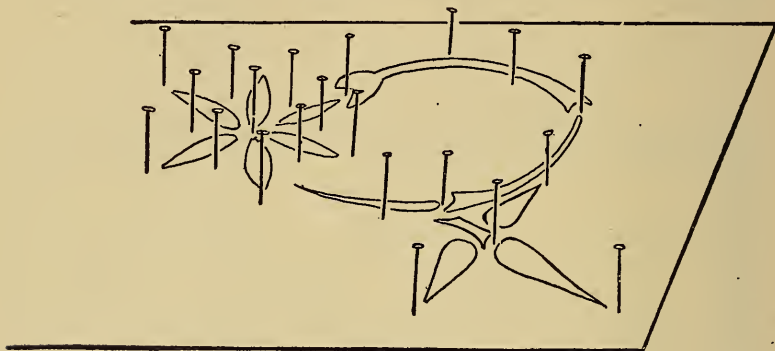

Fig. 641.—Tack the stencil down with pins.

pins. Drive a pin in the centre of each flower, at the point of each petal and at the point of each leaf, between the petals and between the leaves, also in every bridge and along the edges of the design wherever the paper is inclined to lift (Fig. 641). In short, your endeavor must be to keep the stencil perfectly flat on the cloth so that the dye will not penetrate beyond the openings and blur the outlines.

Before tacking the stencil in place

### Make Your Dye Ready

Buy a tube of olive green dye, one of yellow and one of cardinal red. Squeeze about a teaspoonful of dye into a teacup, add two tablespoonfuls of boiling water, stir until dissolved, then

add enough boiling water to give the desired shade. You can test the depth of color by dipping bits of white cloth in the dye. Each dye must be in a separate cup and a little yellow should be added to the green after it is dissolved, but before it is diluted with the extra water. Have ready

#### **Two Stiff Bristle Brushes,**

such as are used for oil painting, and a piece of old white muslin. With your stencil in place, take the board on your lap, set the dye on a stand at your side and lay the old muslin folded on the board above your curtain. Dip a brush in the dye and rub it on the muslin to remove some of the moisture, for a brush too wet will cause the dye to spread and spoil the outline of the design.

Beginning at the left hand of your stencil, scrub the cheese-cloth in the openings of the design until it becomes the right shade and the dye sinks entirely through the cloth. The flowers must be pink and the leaves green, but you can make the flowers darker at the centre if you wish by applying more color. Use separate brushes for the green and red dye. Hold the brush firmly and in an upright position.

When you have stencilled the entire design

#### **Pull Out the Pins,**

move the stencil farther along on the curtain, tack it down and continue stencilling until the border is finished; then take the small stencil of the single flower (Fig. 640) and stencil the flower at irregular intervals over the curtain. For

#### **The Tassels**

which finish the curtains use cheese-cloth colored with the green dye. Cut a strip of cheese-cloth two and half inches wide, spread

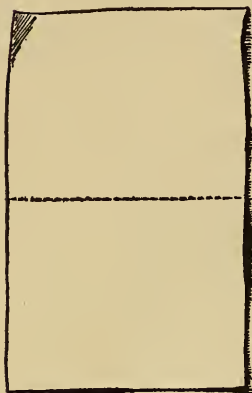

Fig. 642.—Crease the cloth through the centre.

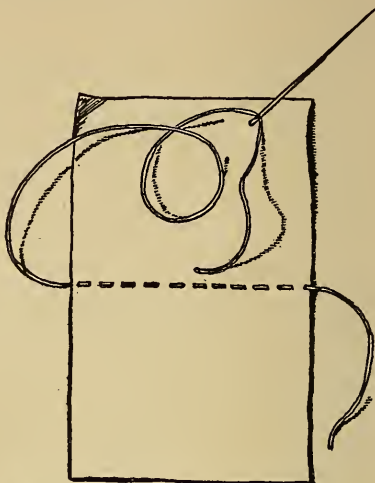

Fig. 643.—Leave several inches of thread at the ends.

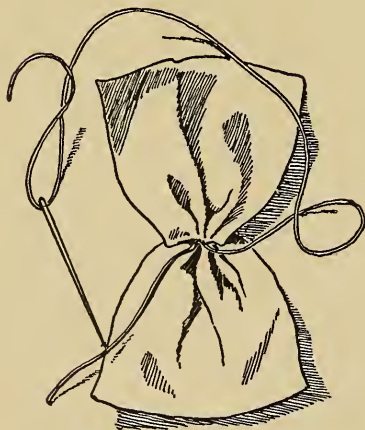

Fig. 644.—Tie securely.

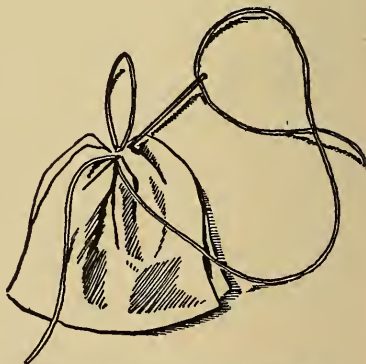

Fig. 645.—Make a loop of the floss.



it flat on the board and paint it with the dye, using your bristle paint brush for the purpose. When the cloth is dry cut it into pieces four inches long. Dye a number of strands of white linen floss, or use green linen or silk floss for tying the tassels.

Fold one piece of the dyed cheese-cloth crosswise through the centre and crease it (Fig. 642). Thread a coarse needle with a strand of the floss and run it through the crease, leaving several inches of the floss at each end (Fig. 643). Draw the material into gathers and tie securely (Fig. 644). Then

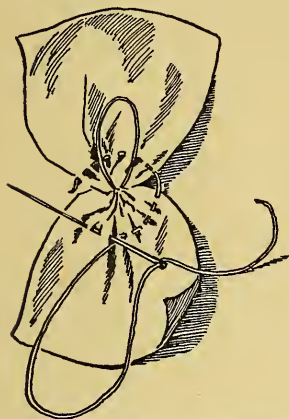

Fig. 646.—Run another gathering thread across each half of the tassel.

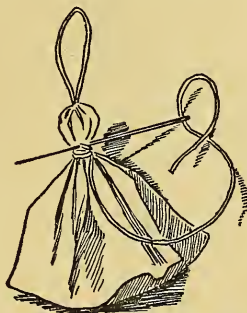

Fig. 647.—Wrap the thread around to form the neck.

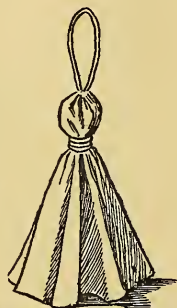

Fig. 648.—Trim off the bottom.

bring the two ends together. Make a loop of the floss about one inch long (Fig. 645), and fasten by taking one or two stitches in the gathers. Open the fold, bring the ends of the floss on the underside of the tassel, tie close to the gathers and cut off the ends. Run another gathering thread across each half of the tassel, half an inch below the gathers at the top (Fig. 646). Draw the thread tight, wrap it around several times to form the neck (Fig. 647), and fasten with several stitches. Cut the floss close to the wrapping and with the scissors trim off the bottom of the

tassel until it is perfectly even (Fig. 648). Sew the tassels several inches apart on the bottom edge of the curtains, as shown in illustration. When the curtains are

#### **To be Laundered**

soak them for an hour or more in a strong solution of salt and water, then wash carefully in the suds of a pure white soap and rinse thoroughly. Do not rub the soap on the material, and before putting the curtain in water shake and brush out all loose dust. Dry in the shade.

# INDEX

## A

Airships, fairy, 70  
Alexandria, Pharos of, 245  
Amytis, 279  
Animal circus, 15  
Apollo, Statue of, 233  
Apple, Hallowe'en, 60  
Apple games, 85  
Ascension, balloon, 11

## B

Baby, Punch and Judy, 52  
Baby porcupine, 68  
Babylon, hanging gardens of, 279  
Babylonians, 283  
Backyard camp, 194  
Ball, tether, 207  
Balloon ascension, 11  
Banana canoe, 401  
Basket, hanging, 372  
Bathing place, 341  
Bayberry candle, 326  
Bead door knobs, 317  
Bean bag test, 66  
Bells, Easter, 364  
Berries, holly, 307  
Blackbirds, girls' fair, 181  
Blarney stone game, 71  
Blind mice, three, 144

Bloodroot, 363  
Board, weaving, 349  
Boat, backyard camp, 202  
Boot, Santa Claus, 169  
Bouquet, 147  
Bowls and cups, 59  
Bowsprit, 408  
Box, Pandora, 12  
Bricks, Babylonian, 286  
Broad-fronted bulls, 293  
Brook, crossing the, 133  
Bud, tulip, 361  
Bulls, Babylonian, 293  
Bushes, bayberry, 326  
Butterfly game, 42

## C

Camels, Egyptian, 228  
Camp, backyard, 194  
Camp-fire, backyard, 201  
Camping outfit, 194  
Candle, bayberry, 326  
Candle-moulds, 331  
Candlesticks, homemade, 385  
Candlewicks, 334  
Canoe, banana, 401  
Card, Easter egg, 363  
Card, tally, 159  
Cardboard Pharos, 244  
Cards, Easter, 358

- Caria, 257  
 Cassiopeia, 421  
 Castor, 423  
 Cats, black, 56  
 Cella, 271  
 Chair, doll's, 370  
 "Chapeau Bras," 377  
 Charades, Pantomime, 6  
 Chares, 233  
 Charm, lava, 67  
 Cheops, 219  
 Chephren, King, 224  
 Chick, good-morning, 381  
 Chicks, Easter, 143  
 Christmas, decorations, 303  
 Christmas tree, living, 173  
 Circus, home, 15  
 Claus, jolly little Santa, 163  
 Clay candlesticks, 386  
 Cnidus, Sostratus, 253  
 Coat, Santa Claus', 169  
 Coloring pottery, 396  
 Colossus of Rhodes, 233  
 Columbus, paper, 405  
 Columbus, to make, 414  
 Columns, temple, 269  
 Coracle, orange skin, 400  
 Costume, Puritan man's, 98  
 Costume, Titania's, 82  
 Costumes, Charades, 7  
 Cotton, stuffing, 237  
 Country picnic, 132  
 Court, pumpkin game, 90  
 Court, tether-ball, 211  
 Cow jumped over the moon, to make,  
     139  
 Cradle, doll's, 372  
 Cross, to make, 360  
 Crossing the brook, 133  
 Crow's-nest, 412  
 Crystal, Japanese, 68  
 Cupid's door, 108  
 Cups and bowls, 59  
 Cups, Santa Claus', 170  
 Curtains, tissue paper, 324
- D
- Dainty bloodroot, 363  
 Dais, upper, 264  
 Daisy Valentine, 110  
 Dance of the dolls, 145  
 Dance, of Titania, 75  
 Date palm, 227  
 Daylight fireworks, 11  
 Deck, forward, 409  
 Deck-fence, 410  
 Decorations, living Christmas tree, 177  
 Diana, temple of, 269  
 Disks, gilt paper, 36  
 Doll house, 315  
 Doll's chair, 370  
 Dolls, dance of the, 145  
 Door, Cupid's, 108  
 Doorknobs, bead, 317  
 Drama, Punch and Judy, 53  
 Dress, Punch's, 50  
 Dress, Puritan woman's, 98  
 Dye kettle, magic, 43
- E
- Easter bells, 364  
 Easter cards, 358  
 Easter chicks, 143  
 Easter egg cards, 363  
 Easter party, 33  
 Egg card, 363

Egg tennis, 33  
 Eggs, to prepare for tennis, 34  
 Egypt, pyramids of, 219  
 Elephant, 20  
 Empress Josephine, 379  
 Entertainment, Valentine, 103  
 Ephesus, temple of Diana at, 269  
 Euphrates, 279  
 Evergreen ropes, 312  
 Express office, girls' fair, 186

## F

Fair, girls', 179  
 Fairy airships, 70  
 Fairy lamp, 403  
 Fairy waters, life in, 141  
 Fence, picnic, 132  
 Fire, backyard, 201  
 Firecracker invitations, 4  
 Fireworks, daylight, 11  
 Flag, 412  
 Flags, flower beds, 157  
 Footstool, Zeus, 265  
 Forfeits, 95  
 Fortune jingle, 71  
 Fortune telling, novel, 55  
 Fourth of July lawn frolic, 3  
 Frieze, doll house, 322  
 Frolic, Fourth of July, 3

## G

Game, Blarney Stone, 71  
 Game, butterfly, 42  
 Game of egg tennis, 39  
 Games, new Easter, 33  
 Garden, plant your, 151

Garden planting game, 159  
 Gardens, hanging, 279  
 Giant firecracker invitation, 4  
 Gilt paper disks, 36  
 Girl, sun-bonnet, 149  
 Girls' fair, 179  
 Glazing candlesticks, 395  
 Goddess Diana, 272  
 Good-night chick, 384  
 Grass, invitation rings of, 55

## H

Half candle, 391  
 Halicarnassus, Mausoleum of, 245  
 Hallowe'en apple, 60  
 Hallowe'en merrymaking, 55  
 Handle, candle, 393  
 Hanging basket, 372  
 Hanging gardens, 279  
 Harmless serpent, 69  
 Hat, peaked, 174  
 Head, Judy's, 51  
 Heart, Valentine, 109  
 Heavier rug, 357  
 Holly, 304  
 Holly berries, 307  
 Hollyhocks, paper, 129  
 Home circus, 15  
 Homemade candlesticks, 385  
 Horse, Rosebud's, 18  
 House, doll, 315  
 Hurling the lance, 10

## I

Impromptu moving pictures, 97  
 Inlaying Zeus' throne, 267  
 Invitation, giant firecrackers, 4

## J

Japanese crystal, 68  
 Japanese tag, 134  
 Jigger sail, 413  
 Jingle, fortune, 71  
 Jolly little Santa Claus, 163  
 Josephine, 379  
 Judy's head, 51

## K

Kettle, magic dye, 43

## L

Lamp, fairy, 403  
 Lance, hurling the, 10  
 Lantern, pumpkin, 93  
 Lava charm, 67  
 Lawn frolic, Fourth of July, 3  
 Leaves, bayberry, 326  
 Leo, 422  
 Life rope, toy, 340  
 Lighthouse, first, 245  
 Living Christmas tree, 173  
 Loom, to weave without, 349  
 Love's palette, 111  
 Lumberman, 344

## M

Mademoiselle Rosebud, 16  
 Magic dye kettle, 43  
 Magic peep show, 137  
 Mainmast, 411  
 Mainsail, 413  
 Main topsail, 412  
 Man, Puritan, 98  
 Marble steps, 252  
 Mausoleum of Halicarnassus, 245  
 Media, 279

Mermaid, 142  
 Mermaid, 345  
 Merrymaking Hallowe'en, 55  
 Mice, three blind, 144  
 Mikado, 374  
 Mistletoe, 310  
 Mizzenmast, 408  
 Modelling tools, 387  
 Moon, cow that jumped over, 141  
 Moulds, candle, 331  
 Moving animal circus, 15  
 Moving pictures, impromptu, 97  
 Myth, 12

## N

Napoleon, 375  
 Nebuchadnezzar, 279  
 Nest, bird's, 373  
 Northern crown, 423  
 Novel Easter party, 33  
 Novel fortune telling, 55

## O

Office, express, girls' fair, 186  
 Olympia, statue of Zeus at, 259  
 Orange games, 85  
 Orange-skin coracle, 400  
 Order of entertainment, 6  
 Original Valentine, 103  
 Orion, 424  
 Outdoor fun, 207  
 Outfit, camping, 194  
 Oyster, sea treasure, 69

## P

Palette, love's, 111  
 Palm, date, 227  
 Pandora box, 12  
 Pantomime, 102

Pantomime, charades, 6  
 Paper Columbus, 405  
 Paper disks, 36  
 Paper shower, 36  
 Party, novel Easter, 33  
 Party, Thanksgiving, 85  
 Pasteboard doll house, 315  
 Peaked hat, 174  
 Peep show, magic, 137  
 Performers, wild west show, 120  
 Pharos of Alexandria, 244  
 Phidias, 259  
 Picnic, roof, 127  
 Pig, to make, 367  
 Pin cushion, 375  
 Pitch-wood fire, 252  
 Plant your garden, 151  
 Plants, Babylonian, 299  
 Platforms, hanging gardens', 284  
 Pole, tether-ball, 207  
 Pollux, 423  
 Porcupine, 68  
 Post-office, 104  
 Postmaster, girls' fair, 192  
 Pottery, coloring, 396  
 Properties, Thanksgiving stage, 101  
 Pumpkin games, 85  
 Punch and Judy show, 45  
 Punch's head, 46  
 Puritan woman, 98  
 Pyramids, 219

## Q

Queen Titania, 75

## R

Race, shuffle, 10  
 Race, wedding, 61  
 Rackets, egg tennis, 38  
 Rackets, palm-leaf fan, 158

Rackets, tether-ball, 214  
 Raft, toy, 341  
 Rapid-transit story, 92  
 Reindeer, Santa Claus, 165  
 Rhodes, Colossus of, 233  
 Rings of grass, invitation, 55  
 Rite, vesper, 65  
 Roof picnic, 127  
 Ropes, evergreen, 312  
 Rosebud, mademoiselle, 16  
 Roses, paper, 130  
 Rug, doll house, 323  
 Rules of egg tennis, 41

## S

Saddle, camel, 230  
 Safe, backyard, 199  
 Sail boat, 373  
 Sails, Columbus' ship, 411  
 Sandpaper for pyramids, 221  
 Santa Claus, 163  
 Santa Maria, 411  
 Saucers, Santa Claus, 171  
 Screen, witch, 66  
 Sea treasure, 69  
 Secret of magic kettle, 43  
 Serpent, 69  
 Shelves, 324  
 Ship, Columbus', 405  
 Show, magic peep, 137  
 Show, Punch and Judy, 45  
 Show, wild west, 113  
 Shower of paper, 36  
 Shrubbery, Babylonian, 297  
 Shuffle race, 10  
 Side steps, Diana's temple, 276  
 Sides, choice of, 160  
 Sleigh, Santa Claus, 164  
 Slides, peep show, 138

Slippers, old, 58  
 Sostratus, 253  
 Sphinx, 225  
 Spool table, 315  
 Spoon, 368  
 Spring, tin-pail, 200  
 Stage, Punch and Judy, 45  
 Stage, Titania's, 75  
 Stamps, Valentine, 107  
 Statue of Zeus, 259  
 Statues, Babylonian, 294  
 Stems, 311  
 Stencil painting, 426  
 Stencils, to make, 426  
 Steps, Diana's temple, 274  
 Steps, marble, 252  
 Story, rapid transit, 92  
 Strawberry, 371  
 Sun-bonnet, charade, 7  
 Sun-bonnet girl, 149  
 Sunflowers, paper, 127

## T

Table, backyard camp, 198  
 Table, spool, 315  
 Table, wild west show, 113  
 Tag, Japanese, 134  
 Tally card, 159  
 Taurus, 425  
 Temple of Diana, 269  
 Tennis, egg, 33  
 Tent, backyard, 197  
 Tent, to make, 123  
 Test, bean bag, 66  
 Tether-ball, 207  
 Thanksgiving party, 85  
 Three blind mice, 144  
 Throne of Zeus, 263  
 Tissue paper glass, 318

Titania's dance, 75  
 Tools, clay modelling, 387  
 Toys, water, 338  
 Tree, living Christmas, 173  
 Trousers, Santa Claus, 169  
 Tulip bed, 361  
 Turtle, 366

## U

Umbrella, 369  
 Upper dais, 264  
 Ursa major, 418  
 Ursa minor, 420

## V

Valentine entertainment, 103  
 Vesper rite, 65  
 Victory, winged, 268

## W

Warp, 350  
 Water life, 141  
 Water toys, 338  
 Wax, bayberry, 331  
 Weaving, 349  
 Wedding race, 61  
 Wicks, candle, 334  
 Wig, Santa Claus, 169  
 Wigwams, 416  
 Wild west show, 113  
 Window glass, 318  
 Winged victory, 268  
 Wings, Titania's, 83  
 Witch screen, 66  
 World, valentine, 109  
 Wreaths, 310

## Y

Yard, camping in back, 194

## Z

Zeus, statue of, 259



## Recreations for Girls

By LINA and ADELIA B. BEARD

Profusely illustrated by the authors. 8vo, \$2.00

---

This new book for girls, by Lina and Adelia Beard, whose previous books on girls' sports have become classic, combines a mass of practical instruction on handicrafts and recreations. No more charming book for girls could be desired.

"It teaches how to make serviceable and useful things of all kinds out of every kind of material. It also tells how to play and how to make things to play with. The girl who gets this book will not lack for occupation and pleasure."

—*Chicago Evening Post.*

### SOME OF THE CHAPTERS

A Home-made Loom  
How to Spin Flax  
Pottery Without a Wheel  
Hallowe'en Revels  
The Magic Cloth  
A New Race of Dolls  
Modeling in Tissue Paper  
Open Air Play Houses  
May Day Amusements  
An Indian Encampment  
A Toy Colonial Kitchen

## Things Worth Doing

AND HOW TO DO THEM

By LINA and ADELIA B. BEARD

Profusely illustrated by the authors. 8vo, \$2.00

---

An infinite variety of things worth doing is comprised in the latest Beard book for girls, which is in every way equal to its widely popular predecessors, and contains a wealth of absolutely new material. How to do the various things worth doing is set forth with that simplicity of direction which has been one of the chief factors in the success of these authors. The text is supplemented by some six hundred drawings.

The book tells of such things as these: A Wonderful Circus at Home, A Valentine Entertainment, A Novel Easter Party, Hallowe'en Merrymaking, How to Get Up a Girls' Fair,

# THE AMERICAN GIRL'S HANDY BOOK

## HOW TO AMUSE YOURSELF AND OTHERS

By LINA and ADELIA B. BEARD

With nearly 500 Illustrations by the Authors

One volume, square 8vo, \$2.00

Eight new chapters have been added to the forty-two which have carried this famous book to the hearts of all the young people since its first appearance, and everything that the girls of to-day want to know about their sports, games, and winter afternoon and evening work, is told clearly and simply in this helpful and entertaining volume. The volume is fully and handsomely illustrated from drawings by the authors, whose designs are in the best sense illustrative of the text.

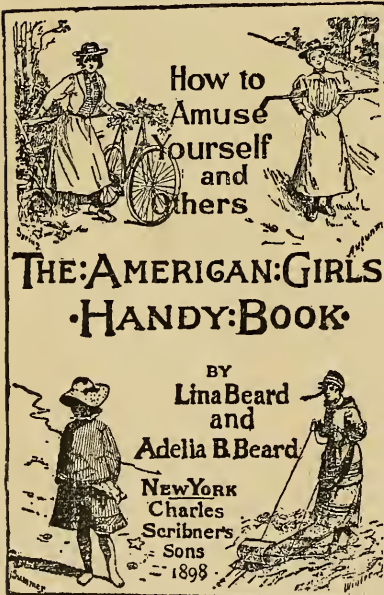

### SUMMARY OF CONTENTS

First of April—Wild Flowers and Their Preservation—The Walking Club—Easter-Egg Games—How to Make a Lawn Tennis Net—May-Day Sports—Midsummer-Eve Games and Sports—Sea-side Cottage Decoration—A Girl's Fourth of July—An Impression Album—Picnics, Burgoo, and Corn-Roasts—Botany as Applied to Art—Quiet Games for Hot Weather—How to Make a Hammock—Corn-Husk and Flower Dolls—How to Make Fans—All Hallow Eve—Nature's Fall Decorations and How to Use Them—Nutting Parties—How to Draw, Paint in Oil-colors, and Model in Clay and Wax—China Painting—Christmas Festivities, and Home-made Christmas Gifts—Amusements and Games for the Holidays—Golf—Bicycling—Swimming—Physical Culture—Girls' Clubs—A New Seashore Game—Apple Target Shooting—Water Fairies.

LOUISA M. ALCOTT wrote: "I have put it in my list of good and useful books for young people, as I have many requests for advice from my little friends and their anxious mothers. I am most happy to commend your very ingenious and entertaining book."

GRACE GREENWOOD wrote: "It is a treasure which, once possessed, no practical girl would willingly part with. It is an invaluable aid in making a home attractive, comfortable, artistic, and refined. The book preaches the gospel of cheerfulness, industry, economy, and comfort."

THE BEARD BOOKS FOR YOUNG PEOPLE

# THE AMERICAN BOY'S HANDY BOOK

Or, What To Do and How To Do It

By DANIEL C. BEARD

One volume, 8vo, fully illustrated by the Author, \$2.00

Mr. Beard's book tells the active, inventive, and practical American boy the things he really wants to know; the thousand things he wants to do, and the ten thousand ways in which he can do them, with the helps and ingenious contrivances which every boy can either procure or make. The author divides the book among the sports of the four seasons; and he has made an almost exhaustive collection of the cleverest modern devices, besides himself inventing an immense number of capital and practical ideas.

## SUMMARY OF CONTENTS

Kite Time—War Kites—Novel Modes of Fishing—Home-made Fishing Tackle—How to Stock, Make, and Keep a Fresh-water Aquarium—How to Stock and Keep a Marine Aquarium—Knots, Bends, and Hitches—Dredge, Tangle, and Trawl Fishing—Home-made Boats—How to Rig and Sail Small Boats—How to Camp Out Without a Tent—How to Rear Wild Birds—Home-made Hunting Apparatus—Traps and Trapping—Dogs—Practical Taxidermy for Boys—Snow Houses and Statuary—Winged Skaters—Winter Fishing—Indoor Amusements—How to Make a Magic Lantern—Puppet Shows—Home-made Masquerade and Theatrical Costumes—With many other subjects of a kindred nature.

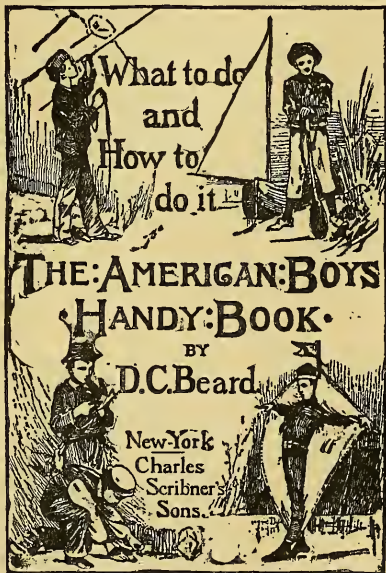

"It is an excellent publication, and is heartily recommended to parents."

—*The Brooklyn Eagle.*

"The book has this great advantage over its predecessors, that most of the games, tricks, and other amusements described in it are new. It treats of sports adapted to all seasons of the year; it is practical, and it is well illustrated."—*The New York Tribune.*

"It tells boys how to make all kinds of things—boats, traps, toys, puzzles, aquariums, fishing tackle; how to tie knots, splice ropes, to make bird calls, sleds, blow guns, balloons; how to rear wild birds, to train dogs, and do the thousand and one things that boys take delight in. The book is illustrated in such a way that no mistake can be made; and the boy who gets a copy of this book will consider himself set up in business."

—*The Indianapolis Journal.*

THE BEARD BOOKS FOR YOUNG PEOPLE

# The Outdoor Handy Book

## FOR PLAYGROUND, FIELD AND FOREST

By DANIEL C. BEARD

With more than 300 Illustrations by the Author. Square 8vo, \$2.00

"It tells how to play all sorts of games with marbles, how to make and spin more kinds of tops than most boys ever heard of, how to make the latest things in plain and fancy kites, where to dig bait and how to fish, all about boats and sailing, and a host of other things which can be done outdoors. The volume is profusely illustrated and will be an unmixed delight to any boy."—*New York Tribune.*

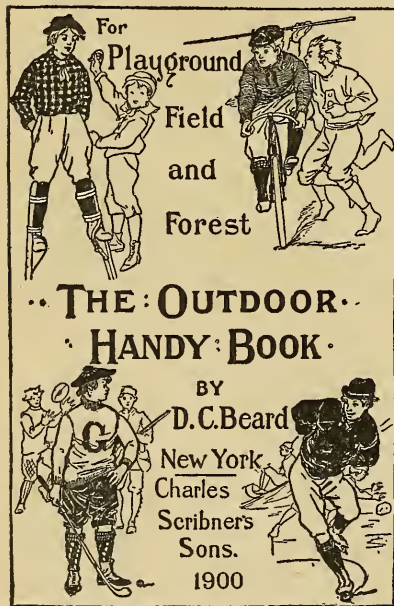

### SUMMARY OF CONTENTS

Marbles—Tops—Latest Things in Kites—Aerial Fish and Dragons—Hoops and Wheels—How to Make the Sucker—Up in the Air on Stilts—Bait, Live and Dead—Fishing—Aquatic Sports—Rigs of All Kinds for Small Boats—Shells and Canoes—Hints for Collectors—Honey-Bee Messengers—A "Zoo"—Choosing Up and "It"—Counting Out Rhymes—Swimming—Games of Tag—I Spy—Leap Frog—Various Sports for Hot Days—Tip Cat—Games of Ball—Mumbly Peg, Hop-Scotch, and Jack Stones—Hints for Cyclists—Camping Out—Boy's Ballista—"Tally-ho!" and Other Cries—Indian Games for Boys—Football—Golf, Hockey, and Shiny—Turtle Hunting—Skating—Stunning Muskrats and Fish—Snowball Battle and Snow Tag—Sleds.

From CHARLES DANA GIBSON: "It makes a man of a boy and a boy of a man."

"This book is praiseworthy from end to end, and will find favor even with those who have long since passed to man's estate."—*The Nation.*

"It is one of the completest things of the kind ever written, and with it one can hardly conceive how a boy could be without pleasant and profitable amusement at any time. It treats of directions for every season of the year, in and out of doors, and on land and water. One of the best things about it is that it furnishes employment for a boy's ingenuity and mechanical skill. It seems as if this book must be destined to an immense popularity."

—*The Advance.*

THE BEARD BOOKS FOR YOUNG PEOPLE

# The Jack of All Trades

OR, NEW IDEAS FOR AMERICAN BOYS

By DANIEL C. BEARD

Profusely Illustrated. Square 8vo, \$2.00

“Every boy who is handy with tools of any sort will enjoy this book.”

—*Youth's Companion.*

“This book is a capital one to give any boy for a present at Christmas, on a birthday, or indeed at any time.”—*The Outlook.*

“Full of new ideas for active boys who like to use tools and see interesting things growing under their hands.”

—*N. Y. Tribune.*

“A perfect treasure-house of things that delight the soul of a boy and keep him happy and busy.”—*The Interior.*

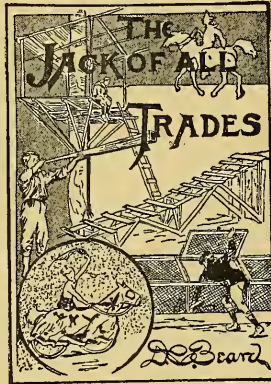

## CONTENTS

### Part I. Fair Weather Ideas

Tree-Top Club-Houses—How to Capture and Trap Small Live Animals—The Back-Yard Zoo—A Back-Yard Fish-Pond—Pigeon and Bantam Coops—How to Make a Back-Yard Aviary—A Boy's Back-Yard Workshop—How to Build an Underground Club-House—A Boys' Club-House on the Water—How to Have Fun on a Picnic—How to Build and How to Furnish a Daniel Boone Cabin—Flat Boatman's House—The American Boy's House Boat—Back-Yard Switchback—How to Build a Toboggan Slide in the Back-Yard.

### Part II. Rainy Weather Ideas

A Home-Made Circus—Good Games with Toothpicks and Matches—Fun with Scissors and Pasteboard and Paper—How to Prepare and Give a Boys' Chalk Talk—A Christmas Novelty for Boys—How to Make Two Boys into One Santa Claus—A Circus in the Attic—A Boys' Stag Party—A Wild West Show in the House—How to Have a Panorama Show.

CHARLES SCRIBNER'S SONS, Publishers

153-157 Fifth Avenue, New York

Lehrer

241173  

---

SapC  
142

1





















LIBRARY OF CONGRESS

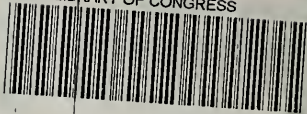

0 003 443 817 1

